

ACTIONPOWER

High Power Grid Simulator

Titan AC series

0V to 576V, 300kVA to 7.5MVA



Regenerative AC Source



actionpowertest.com

HIGH POWER CAPACITY WITH PARALLEL OPERATION

With 300kVA - 750kVA of unit capacity, the total capacity can be expanded up to 7.5MVA by parallel connections.

576V
**MAXIMUM
AC OUTPUT
VOLTAGE**

7.5MVA
**MAXIMUM
AC OUTPUT
POWER**

**MULTI-
OUTPUT
MODE**

Multiple AC power supply cabinets can individually operate in single mode to configure multi-channel output, or in Master/Slave mode to configure single-channel output with combined capacity.

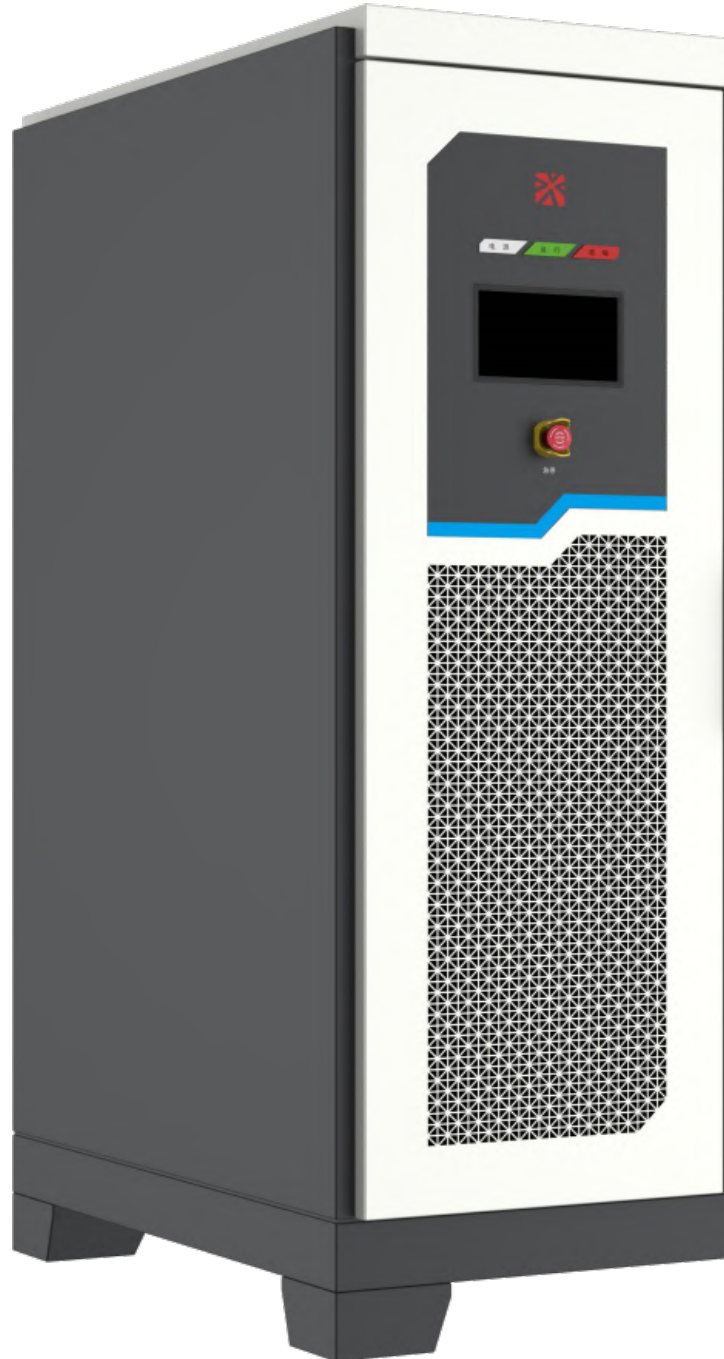

FULLY TEST AC POWER WITH 4-QUADRANT

Full four-quadrant control enables reliable and efficient conversion of desired voltage and current with power regenerated to the grid.

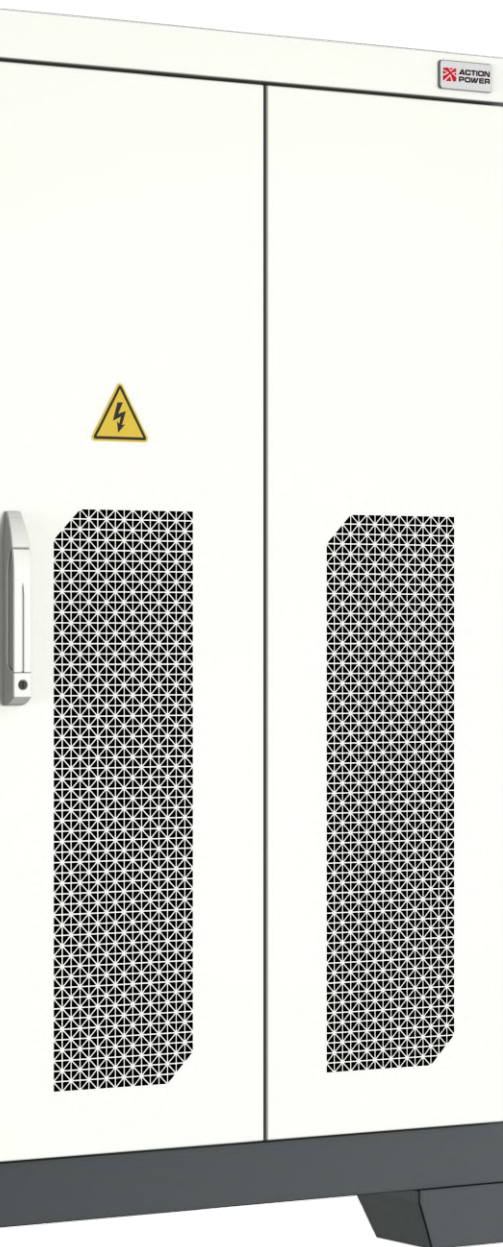

RLC
**REGENERATIVE
AC LOAD**

0.1°
**PHASE ANGLE
RESOLUTION**

359.9°
**PHASE ANGLE
CONTROL**

COMPREHENSIVE PHASE CONTROL

Simultaneous control of three phases up to 359.9° by unit angle of 0.1°, and phase angle of each of A, B, and C can be changed with the accuracy of 0.1%.

Ratings, types and voltages

Model	Output Power [kVA]	Voltage Range [V] @ L-N	Frequency Range [Hz]	Max. Current [A] @ 3 phase	Size (WHD) [mm]	Weight [kg]
TA300-576-03	300	0-576	40-70	300	2410x1955x1200	2,960
TA400-576-04	400	0-576	40-70	400	2410x1955x1200	2,960
TA500-576-05	500	0-576	40-70	500	2410x1955x1200	2,960
TA600-576-06	600	0-576	40-70	600	3410x1955x1400	5,300
TA750-576-07	750	0-576	40-70	750	3410x1955x1400	5,300

Titan AC series 300kVA

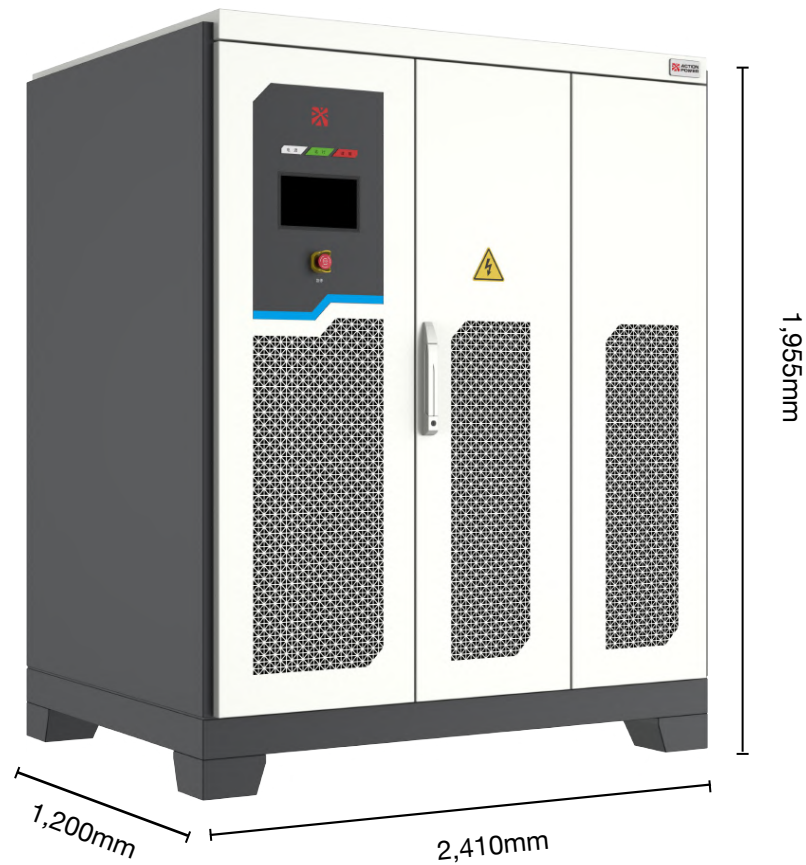

Technical data

Titan AC series	Specification
AC Input	
Voltage, Phases	380V±15%, 3ph+PE
Frequency	47Hz to 63Hz
Harmonic current	<3%
Power factor	0.99
AC Output Voltage	
Accuracy	±0.1% F.S.
Resolution	0.01V
Load regulation	±0.1% F.S. @ Linear load
Line regulation	±0.1% F.S. @10%
Voltage slew rate	AC>1.0V/μs
Response time	<1ms (10%-90%Umax)
Voltage distortion	Less than 0.5% @50Hz/60Hz ≥ 220V for no-load
	Less than 1% @50Hz/60Hz ≥ 220V for linear load
	Less than 1.0% @ other frequency ≥ 220V for no-load
	Less than 1.5% @ other frequency ≥ 220V for linear load
AC Output Current	
Accuracy	±0.2% F.S.
Resolution	0.1A
Output Frequency	
Accuracy	±0.005%
Resolution	0.001Hz
Range	40-70Hz
Phase Angle Control	
Accuracy	±0.3°
Resolution	±0.1°
Phase angle range	0 - 359.9°
Phase control	Single-phase, Three-phase, Three-phase independent
Voltage Ride Through	
Mode	LVRT / HVRT
Setting parameter	Voltage, frequency, phase, rise time, hold time, trigger phase angle and pulse output

Technical data

Titan AC series	Specification
Harmonic Injection	
Order	50th@50Hz/60Hz
Content	Harmonics of the 2nd to 10th order: single harmonic content $\leq 40\%$, Total Harmonics Distortion (THD) $\leq 60\%$;
	Harmonics of the 10th to 20th order: single harmonic contents $\leq 20\%$, Total Harmonics Distortion (THD) $\leq 20\%$;
	Single harmonics of orders 21~30: maximum 10%, total harmonics no more than 10%;
	Single harmonics of orders 31~50: maximum 5%, total harmonics no more than 10%
Amplitude error	$\pm 5\%$ harmonic of set value
Preview function	Harmonic synthesis waveform can be previewed
Editing mode	Import, export, read, storage
Inter Harmonic	
Frequency range	1Hz-2500Hz, content $< 10\%$
Programming steps	100 steps
Programming parameters	Content, Start Frequency, End Frequency, Frequency Increment, Execution Time Interval Time, Number of Cycles, Sequence
Editing mode	Add, delete, import, export, store, read
Flicker	
Flicker level	1.0-10.0, totally 10 levels in total, and one-key calling
Adjustment step length	1
Accuracy	± 0.2
Preview function	Preview of flicker trend chart, pst can be visualized Resolution
N/A	
Three-phase unbalance	
Adjustment mode	Three-phase voltage, phase, single phase, unbalance factor, duration
Unbalance factor range (%)	1~100
Unbalance factor step length (%)	0.01%
Accuracy (%)	$\pm 0.5\%$
Preview function	Three-phase unbalance trend chart can be previewed
Measurement	
Voltage accuracy	$\pm 0.1\%$ F.S.
Frequency accuracy	$\pm 0.005\text{Hz}$
Current accuracy	$\pm 0.2\%$ F.S.
Active power accuracy	$\pm 0.3\%$ F.S.
Apparent power accuracy	$\pm 0.3\%$ F.S.

High Power Scalable Design

The Titan AC series support multi-unit parallel operation and adopts high-speed fiber optic communication technology, featuring strong anti-interference capability and zero latency. The system supports expansion up to 7.5MVA, with technical specifications equivalent to a single unit capacity of 300kVA - 750kVA. It enables multi-position, high-capacity, and multi-voltage level test setups, significantly improving testing efficiency for customers. In particular, the parallel-connected panels can be used in multi-output mode by separating the outputs according to the user's needs, allowing multiple test equipment to be tested at the same time, maximizing user convenience and saving a lot of costs.

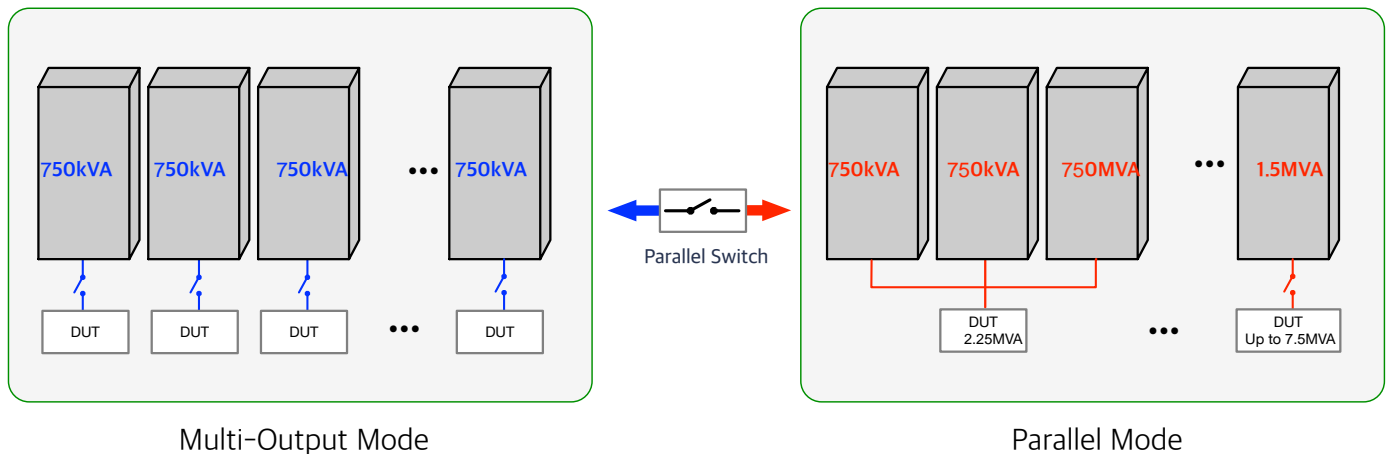

Output Expansion up to 7.5MVA with Master / Slave Control

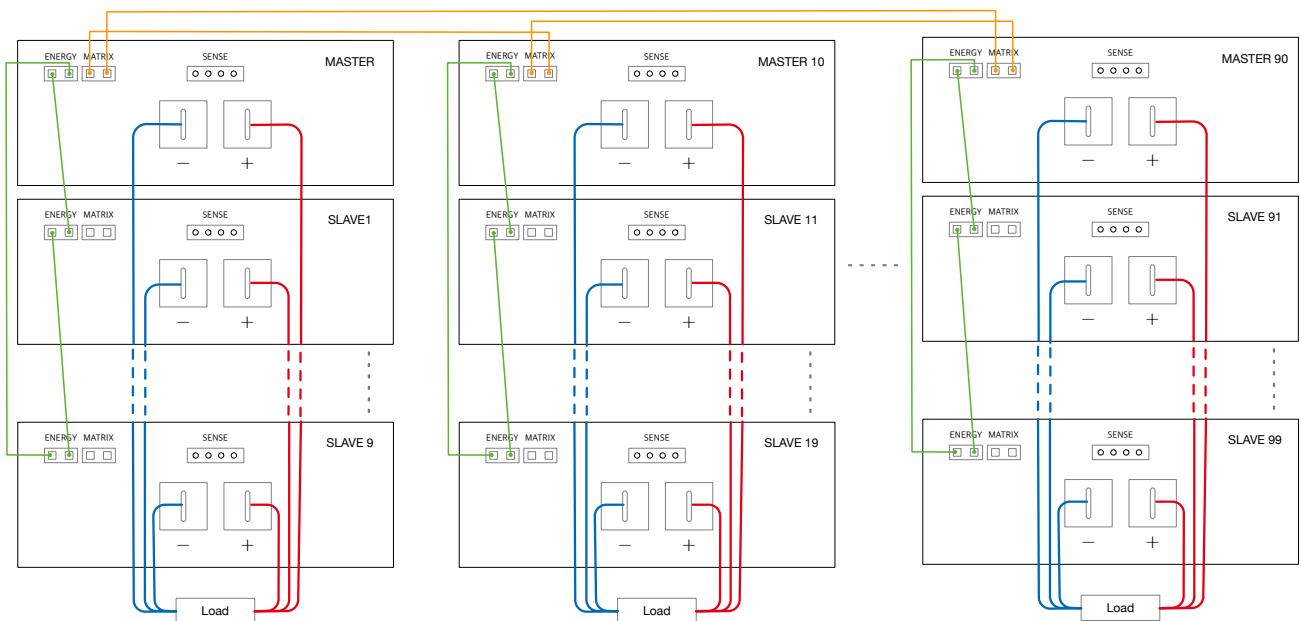

Application

The Titan series are innovative products used in a variety of applications due to its unique technology and optimal performance. It can perform bidirectional AC power supply and act as regenerative AC loads, which can be utilized for long-term reliability testing applications including tests for ESS, PV inverter, wind turbine, electric vehicle DC charging stations, and a variety of grid-connected systems. They are particularly well suited for applications that require accurate and extremely fast response times when simulating AC power characteristics.

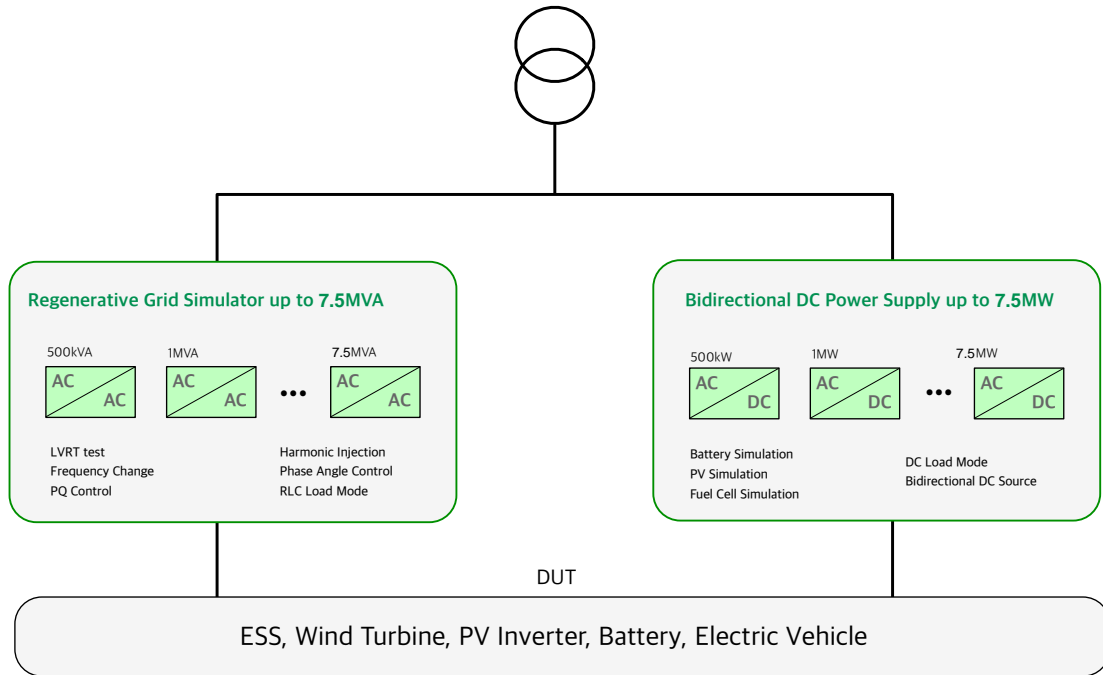

ESS Testing



PV Inverter Testing



Wind Turbine Testing

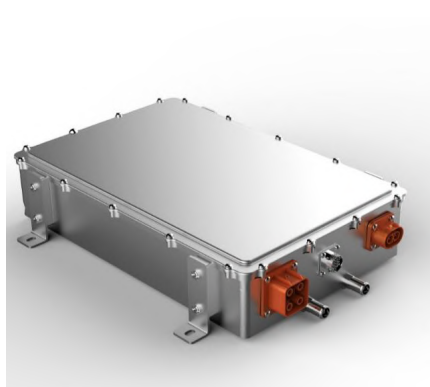

AC/DC Power Supply Testing



EV Charger & EVSE Testing

4-Quadrant Control

With four-quadrant control, Titan AC series can test PV inverters, V2G, EV chargers, EVSE, batteries, UPS, and AC/DC power supplies. It has a built-in load option as standard and can operate in any four-quadrant with programmable phase control. It can simulate inductive and capacitive loads, allowing you to test a full range of AC power loads.

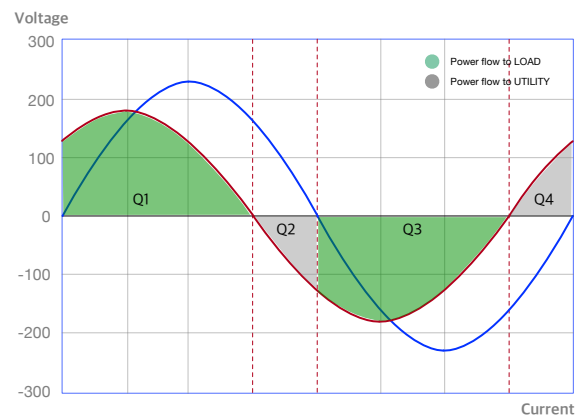
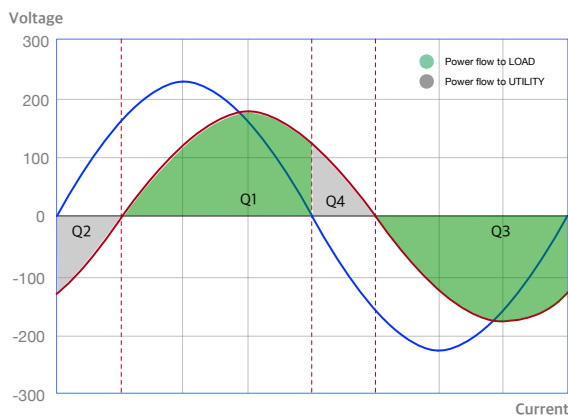

High Dynamics

The output voltage slew rate of power supply is up to $1V/\mu s$, which can simulate the 1ms continuous interruption from the power grid.

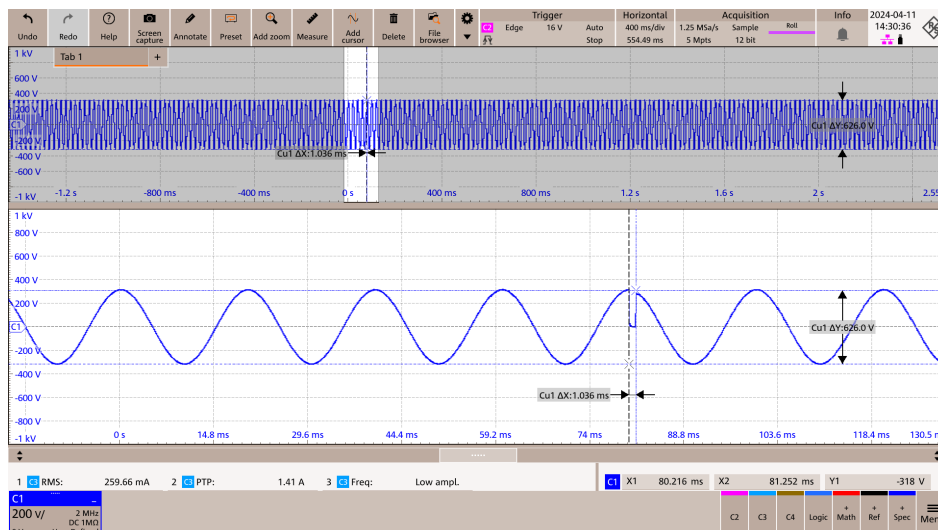

1ms Interruption

Harmonics / Inter-harmonics

The 49 harmonics can be superimposed simultaneously, and the total harmonic content can be set up to 40%

The power supply has two harmonic injection modes, the three-phase independent injection and the three-phase linkage injection, allowing the superimposition of 2-50th of harmonics with 50Hz or 60Hz basic frequency, or allowing the superimposition of 1Hz-2500Hz inter-harmonics to form the distorted waveform of output voltage. It can be used for the tests under GB/T 14549-1993, and GB/T 24337-2009. The power supply has 27 built-in DST waveforms and 100 customized waveforms that can be called by one click.

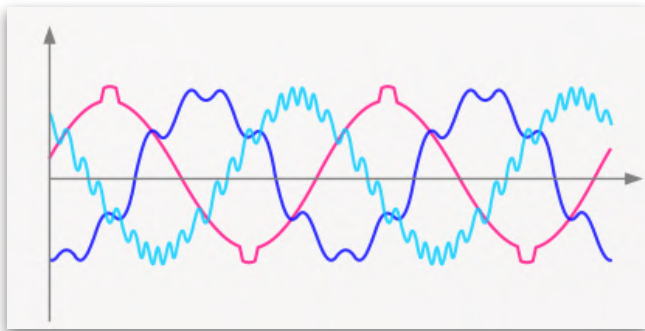

Harmonic Superposition Waveform

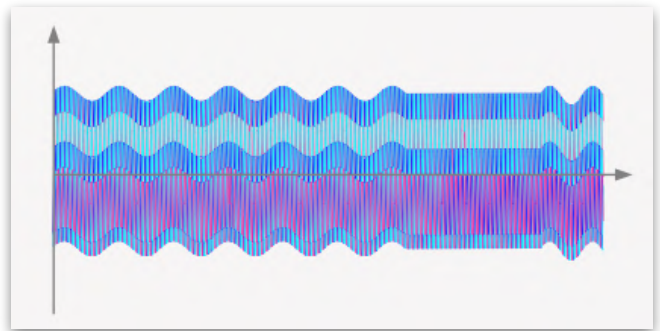

Inter-harmonic Superposition Waveform

Starting frequency, ending frequency, interval and the like can be set for inter-harmonics to test the inter-harmonic sweep frequency, so as to meet the tests of IEC61010-1, etc.

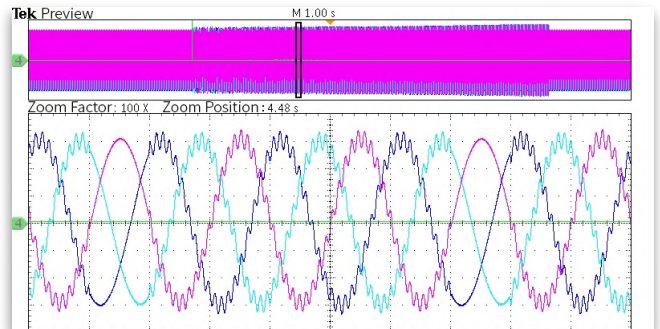
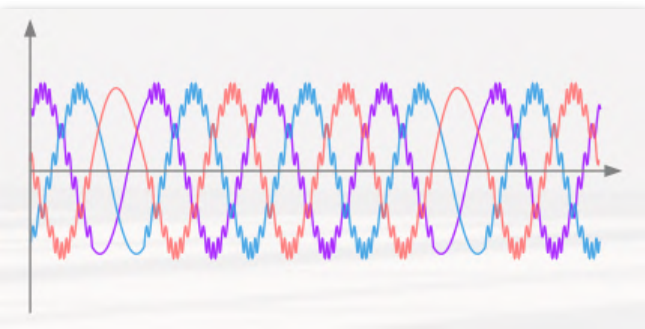

Inter-harmonic Sweep

Independent setting of three phases

Simulate normal and abnormal characteristics of various power grids

The three-phase output of the power supply can be set independently, which can simulate the normal and abnormal characteristics of three-phase balance or unbalance of various power grids. It can be set by individual or multiple programmable output on voltage, phase etc. of both single-phase and multi-phase.

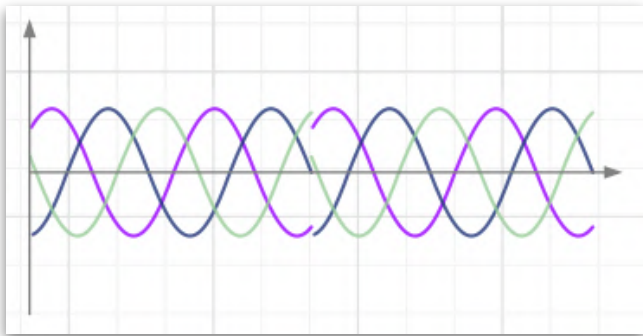

Phase Change

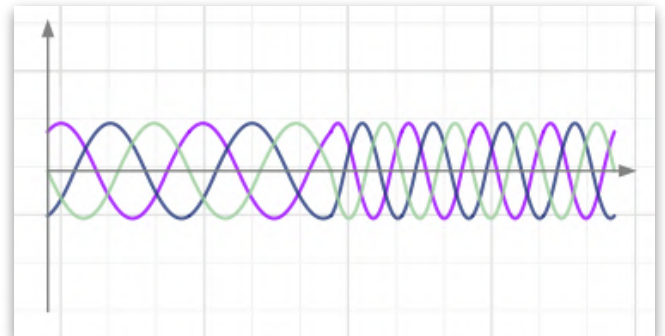

Frequency Change

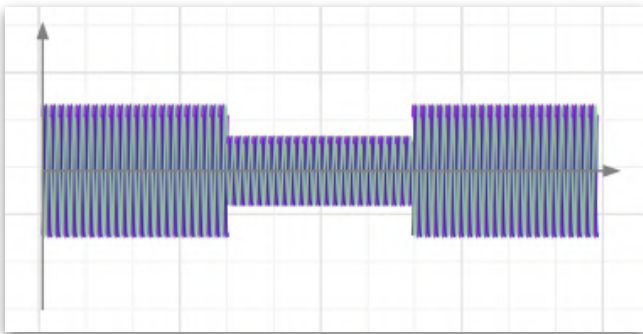

Voltage Change

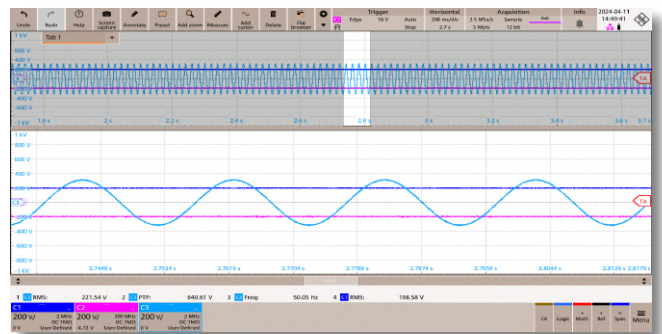

Phase Split

Voltage Ride Through

Typical rise / fall time within 1ms

The single-phase, two-phase, and three-phase H/LVRT tests can be performed for the power supply. The trigger phase angles of the ride through points can be set for the power supply to meet the requirements of tests under various standards. The minimum setting voltage of power supply is less than 5V, and 10%-90% rise/ fall time is 1ms.

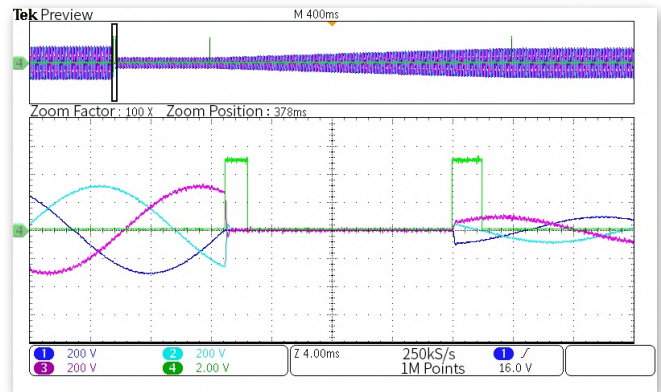
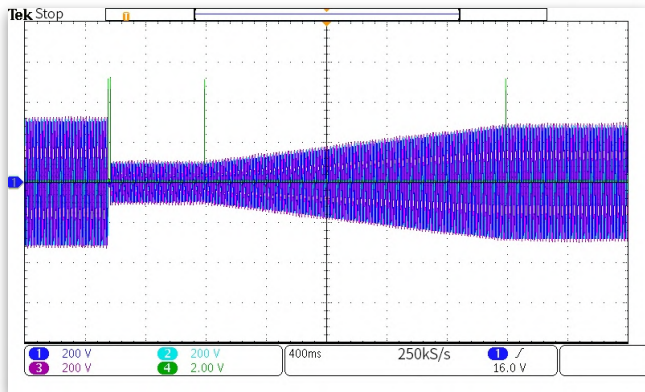

Three-Phase Low Voltage Ride Through

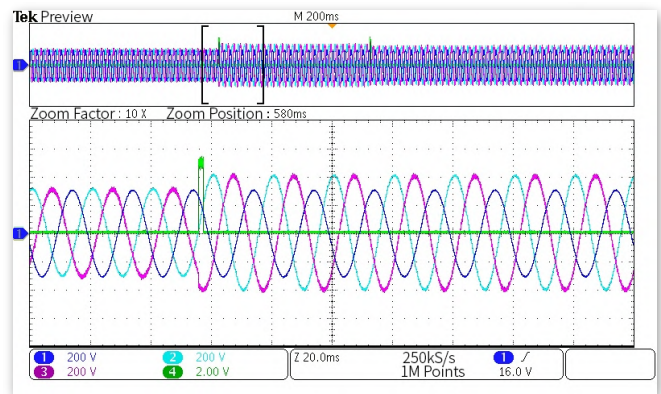
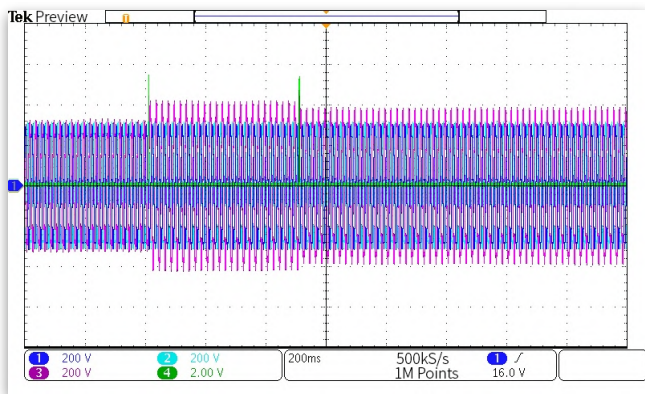

Single-Phase High Voltage Ride Through

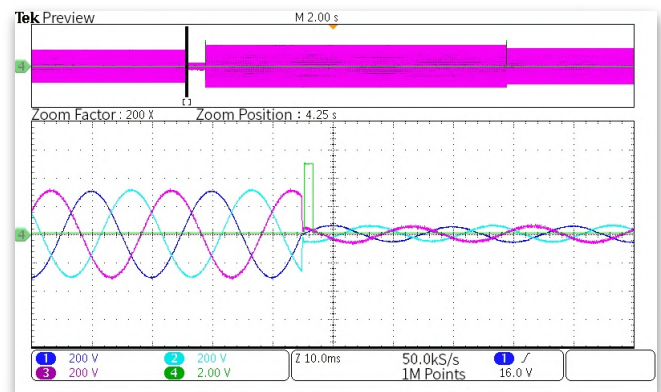
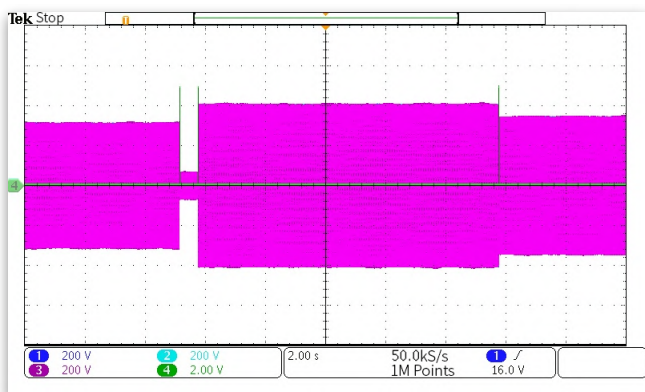

Three-Phase High Voltage Ride Through

Voltage Ride Through

Phase A, B and C can be changed at the same time for low voltage ride through, phase B and C can be switched for low voltage ride through, so as to meet the tests of VDE-AR-N 4105 regulations.

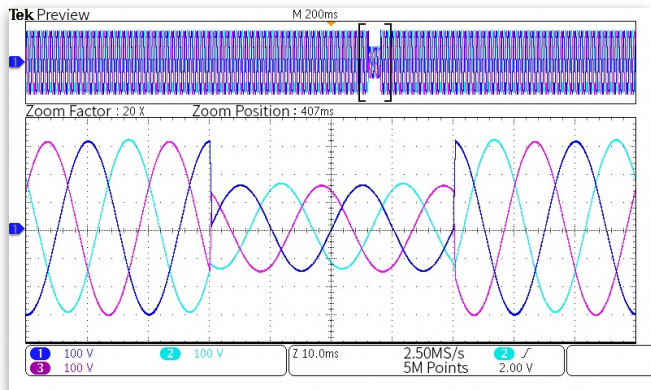

Three-Phase Change LVRT

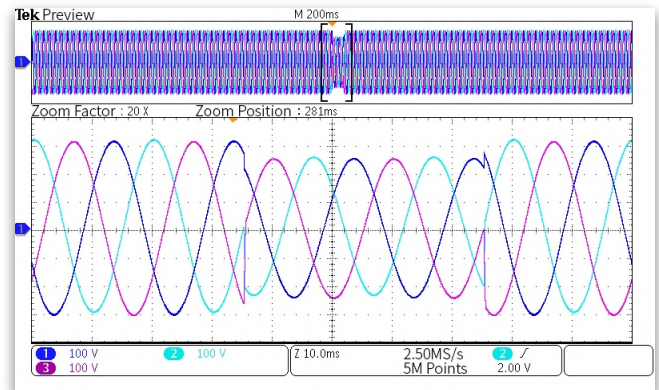

B-C Phase Shift LVRT

Flicker Simulation

Levels 1~10 can be called directly

The power supply supports the setting of flicker levels: the flicker trend chart can be previewed, and the pst can be visualized. The flicker characteristics of the power grid can be easily simulated to test flicker adaptability of the test object.

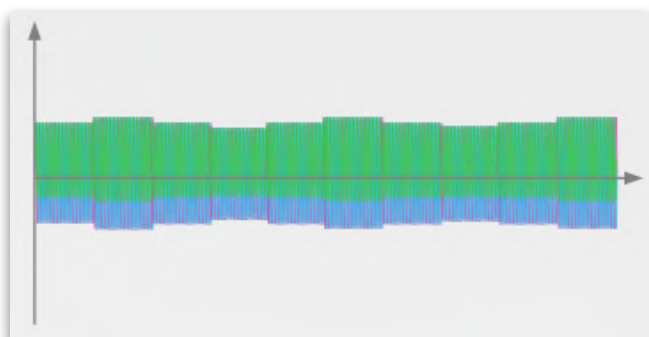

Flicker simulation waveform

Powerful Software



Provides Diverse Simulation Modes

Low Voltage Ride-Through (LVRT) and Area Electrical Power System (EPS) Disturbance Simulation

Titan AC series can easily simulate tests such as LVRT test patterns with provided software, accurately control user-defined waveforms, and add features depending on the test environments.

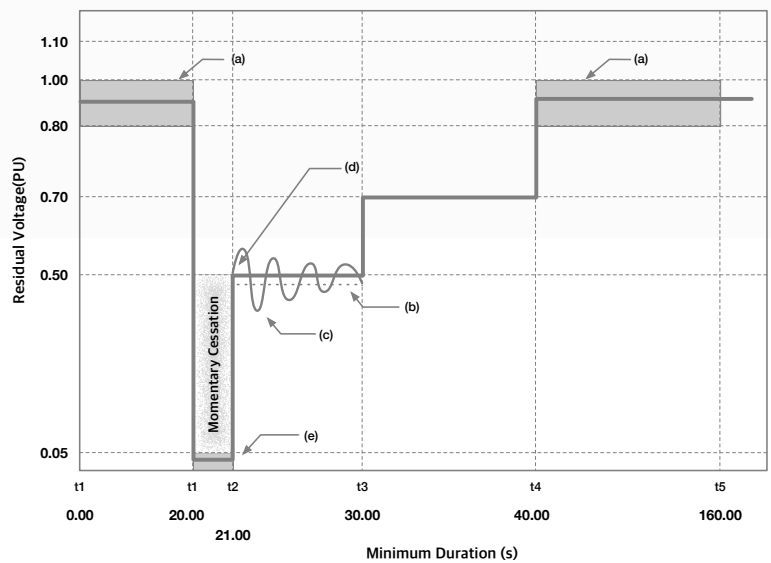

ACTIONPOWER

For more information, please contact
your local ACTIONPOWER distributor or visit

www.actionpowertest.com

© Copyright 2026 ACTIONPOWER. All rights reserved.
Specifications subject to change without notice.

Headquarters

No.3333 Run De RD., Chang An District, Xi'an Shaanxi, China 710119

info@actionpowertest.com

+86 (0)29-8569-1870