

CORTEX-B Series Bidirectional Programmable Direct Current Power Supply User Manual

CORTEX-A Series Programmable Direct Current Power Supply User Manual



All rights reserved. Reproduction is prohibited. Subject to change without notice.



Table of Contents

1	Contact Us	9
2	Warranty and Safety Information	10
2.1	About This Manual	10
2.1.1	Retention and Use	10
2.1.2	Copyright	10
2.1.3	Validity.....	10
2.2	Limited After-Sales Warranty	11
2.3	Safety Information	13
2.3.1	Meaning of Safety Symbols.....	13
2.3.2	Safety Rules	15
2.3.3	Safety Precautions	15
3	Product Overview	23
3.1	Basic Description	23
3.2	Product Appearance	24
3.3	Product Features	26
3.4	Function Block Diagram	27
3.5	Technical Specifications.....	27

3.6	Standard Configuration List.....	93
4	Unpacking and Installation.....	95
4.1	Handling and Storage.....	95
4.1.1	Handling.....	95
4.1.2	Storage.....	95
4.2	Inspection.....	95
4.3	Environmental Requirements.....	96
4.3.1	Ventilation and Derating.....	96
4.3.2	Noise.....	99
4.3.3	Liquid Protection.....	99
4.3.4	Cleaning.....	99
4.4	Installation Specifications.....	100
4.5	Rack Ear Connection.....	102
4.6	Handle Connection.....	103
4.7	Foot Pad Installation.....	104
4.8	AC Terminal Connection.....	105
4.9	PE terminal connection.....	109
4.10	Output terminal connection.....	110
4.11	Remote Compensation Connection.....	113

4.12	Magic-Box/ Magic-Bus Installation	116
4.13	Anyport Interface Installation	118
4.14	Energy Matrix Interface Installation.....	119
5	Front Panel	121
5.1	User Notice.....	121
5.1.1	Important Notice.....	121
5.1.2	General Notice	121
5.2	Front Panel Layout.....	121
5.2.1	Display Screen	123
5.2.2	External Storage Interface.....	123
5.2.3	Power/Reset Button	123
5.2.4	Output Button	123
5.2.5	Left/Right Knob and Button.....	123
5.3	Power/Reset Button Related Operations	124
5.3.1	Power On/Off	124
5.3.2	Automatic Startup.....	126
5.3.3	Reset	126
5.4	Output Button Related Operations	127
5.4.1	Manual Output.....	127

5.4.2	Automatic Output.....	128
5.4.3	Output Connection/Disconnection Delay.....	129
5.4.4	Operating Sequence.....	130
6	Rear Panel.....	132
6.1	Anyport Interface.....	133
6.2	LAN interface.....	137
6.3	USB interface.....	137
6.4	Optional Interface.....	138
6.5	SENSE Interface.....	138
6.6	Output Busbar Positive/ Negative Electrode.....	138
6.7	Three-pin input connector.....	139
6.8	PE connector.....	139
6.9	AC terminal circuit breaker.....	139
7	Display Screen Functions and Operations.....	140
7.1	Main Interface.....	140
7.1.1	Dropdown Shortcut Area.....	141
7.1.2	Status Display Area.....	142
7.1.3	Output Display Area.....	146
7.1.4	Function Editing Area.....	152

7.1.5	Home/Menu Key	156
7.1.6	Output Settings Area	158
7.2	Programming	159
7.2.1	List.....	160
7.2.2	Wave.....	168
7.2.3	Step	172
7.2.4	Advanced	177
7.2.5	Arbitrary Wave	189
7.3	Anyport.....	194
7.3.1	Digital	195
7.3.2	Analog.....	197
7.4	SAS (Solar Array Simulator)	200
7.4.1	SAS Main Interface	201
7.4.2	SAS Static Curve	202
7.4.3	SAS Curve Scan.....	210
7.4.4	SAS Custom Curve.....	214
7.5	BatSim (Battery Simulator)	215
7.5.1	Main Interface	216
7.5.2	Cell Parameters.....	216

7.5.3	Settings	219
7.5.4	Cycle.....	220
7.5.5	BatSim Alarm	221
7.5.6	BatSim Protection	223
7.6	Mode	232
7.7	Parameters.....	232
7.8	Limit Value	237
7.9	Protection	259
7.10	Event	275
7.11	Communication	279
7.12	Advanced	282
7.13	Storage.....	287
7.13.1	Information.....	287
7.13.2	Log.....	288
7.13.3	Parameters.....	290
7.13.4	Waveform	292
7.13.5	File.....	292
7.14	Parallel.....	294
7.15	System.....	300

7.15.1	Screen.....	300
7.15.2	About.....	300
	Version Revision Record	302

1 Contact Us

Address: China • Shaanxi • Xi'an New Industrial Park, Information Avenue No. 12

Postal Code: 710119

Phone:+86(029) 85691870 85691871 85691872

Fax:+86(029) 85692080

Website: www.actionpowertest.com

Email: Info@actionpowertest.com

2 Warranty and Safety Information

2.1 About This Manual

2.1.1 Retention and Use

This manual should be placed near the product for easy reference during operation. When the storage location and/or user of the equipment change, it should be transferred together.

2.1.2 Copyright

Reproduction or copying of this user manual, in whole or in part, for any other purpose is strictly prohibited, and legal consequences will be borne for such actions.

2.1.3 Validity

This user manual is a general user manual for CD-B and CD-A series products and is only valid for the following specifications/models:

30kW Model			
CD30-800B	CD30-1K0B	CD30-1K5B	CD30-2K0B
CD30-800A	CD30-1K0A	CD30-1K5A	CD30-2K0A

20kW Model		15kW Model	
CD20-1K5B	CD20-1K0B	CD15-1K5B	CD15-1K0B
CD20-2K0B	CD20-800B	CD15-2K0B	CD15-800B
CD20-1K5A	CD20-1K0A	CD15-1K5A	CD15-1K0A
CD20-2K0A	CD20-800A	CD15-2K0A	CD15-800A

20kW Model			15kW Model		
CD20-040B	CD20-060B	CD20-080B	CD15-040B	CD15-060B	CD15-080B
CD20-040A	CD20-060A	CD20-080A	CD15-040A	CD15-060A	CD15-080A

2.2 Limited After-Sales Warranty

Xi'an ActionPower Electric Co., Ltd. guarantees free repairs for any faults or damage occurring under normal use within one year from the date of delivery of the products manufactured and sold by the company.

During the warranty period, the company is not responsible for free repairs in the following situations, and repair charges will be applied based on the repair conditions.

Usage beyond the design purpose of this product.

Used by untrained personnel.

Reassembled by the customer.

Used unauthorized parts.

Products not directly sold by our company or officially authorized dealers.

Disassembled, repaired, modified, or added accessories without the company's consent, causing faults or damage.

Due to irresistible disasters, or attributable to the user's failure to follow the operation manual or user negligence, such as improper operation or other handling causing faults or damage.



During the warranty period, for products with faults or damage, the user is responsible for delivering them to the company, with costs borne by the user. After repair, the company will cover the costs of delivering the product back to the user (limited to mainland regions) or to a designated location (limited to mainland regions).

This 'warranty' does not cover all other express or implied warranties.

2.3 Safety Information

2.3.1 Meaning of Safety Symbols

Warning paragraphs, safety tips, and general tips in this document will appear in boxes with the following symbols:

	Tip. Be sure to read the user manual of this product in detail first.
	Note! Important operation tips, endangering the product, High voltage danger/Electric shock hazard
	Warning! Endangering personal and life safety

Details of Precautions:

	<p>The product must only be used according to its designed purpose.</p> <p>Use of the product is only permitted within the range specified on the product label.</p> <p>Do not insert any objects, especially metal parts, into the product's ventilation holes.</p> <p>Avoid using liquid substances around the product.</p> <p>Avoid the product from getting damp, wet, or covered with condensation.</p> <p>When using as a DC source, do not connect the load to the product when the output is on, as it may cause sparks, leading to fire, and damage to the equipment or load.</p> <p>When using as an electronic load, do not connect the power source to the product when the DC input is on, as it may cause sparks, leading to fire, and damage to the equipment or power source.</p> <p>When operating the interface card, be sure to follow the ESD requirements and rules.</p> <p>When operating interface cards, you must turn off the product before inserting or removing interface cards or modules, this operation does not require opening the product enclosure.</p> <p>External power sources must not be connected in reverse to the product's output! Even if the product is completely turned off, it will still cause damage to the product.</p> <p>Before use, you must set various protection functions to avoid over-voltage, over-current, over-power, and other parameters to match the load connected to the product.</p>
---	--

	<p>Do not connect external power sources that produce voltages higher than the product's rated voltage to the product! The AC side of this product should only and exclusively be connected to the power grid! Application scenario: Indoor. Overvoltage Category: III. Power Supply System: TT or TN. Output: Maximum Additional Transient Overvoltage=1500V, applicable only to models with an output of 1 500. Do not connect the output to the main power supply, if necessary, the output should be isolated from the main power supply through a transformer. The primary winding in the transformer is separated from the secondary winding by basic insulation.</p>
--	---

Warning Details:

	<p>The operation of electrical equipment implies that certain parts of the product carry hazardous voltage. Therefore, all parts with voltage must be covered with protective covers! When the product is just disconnected from the mains, never directly touch the power cord or the connecting plug, as there is still a risk of electric shock! Do not touch the output terminal directly when it is turned off, as there is still a dangerous voltage present! When the product is still running, even if the product's DC output/input is not turned on, there will be a dangerous voltage between the DC negative/positive and the ground! When operating the equipment, always follow these five safety rules: Completely disconnect from the power grid and load! Ensure no overlapping connections! Confirm the equipment has completely stopped outputting! Perform grounding and short-circuit operations! Install protective devices for adjacent live components! When the product is running and the DC output is turned on, the output terminal may have voltage or may not completely drop to zero! When the product is operating, the DC output is turned off, the output terminal can still produce a small non-loadable voltage (<2 V)!</p>
---	--

2.3.2 Safety Rules

Do not install or replace substitute parts or perform any unauthorized modifications. For repairs, please return the instrument to our company's repair department to ensure its safety features.

Please refer to specific warnings or cautions in the user manual to avoid personal injury or instrument damage.

To prevent electric shock, unauthorized personnel not authorized by our company are strictly prohibited from disassembling the machine.

This product is strictly prohibited from being used in life support systems or any other equipment with safety requirements.

We are not liable for any direct or indirect financial loss that may occur while using this product.

2.3.3 Safety Precautions

At all stages of operation, maintenance, and repair of this product, general safety precautions or specific warnings elsewhere in this manual must be followed. If the safety standards of design, manufacture, and intended use of the equipment are violated, Xi'an ActionPower Electric Co., Ltd. assumes no liability for claims due to the customer's failure to comply.



Warning: I Class Equipment

This product is a I class safety device (with a protective grounding terminal), and if used in a manner not specified in the user manual, its protective function may be impaired.



Warning: Environmental Conditions

This product is only suitable for installation in an indoor environment with pollution degree 2, altitude not exceeding 2000m, overvoltage category OVC III, and should avoid direct sunlight, dust, flammable or explosive gases, and strong magnetic fields. Its operating temperature is 0-40°C, and relative humidity is less than 75%.



Note: Before Powering On

Ensure that the AC input specifications indicated on the nameplate match the voltage, frequency, and other parameters of the available public power grid.



Safety Precautions: Grounding

This product is a Class I safety device (with protective grounding terminal). To reduce the risk of electric shock, the equipment chassis grounding terminal must be connected to electrical safety ground. The equipment must be connected to the AC power supply through a properly rated three-phase cable (L1-L2-L3-PE) with protective grounding.

Disconnection of the protective (grounding) conductor or protective grounding terminal will result in a potential electric shock hazard, which may lead to personal injury.

The equipment is equipped with a line filter to reduce electromagnetic interference and must be properly grounded to minimize the risk of electric shock. Operating at a line voltage or frequency exceeding the voltage or frequency specified on the model nameplate may result in leakage current exceeding 5.0 mA peak.



Warning: Do not operate in explosive environments.

Do not operate the device in an environment with flammable or explosive gases.



Warning: Disconnecting Device

The AC input connection must include a disconnecting device (external switch or circuit breaker) as part of the installation. The disconnecting device must be located at an appropriate position on the AC side and must be marked as the disconnecting device for the equipment. The disconnecting device must disconnect all conductors simultaneously.

An external overcurrent protection device (such as a fuse or circuit breaker) must be provided.

The breaking capacity of the overcurrent protection device should match the rated current of the device.

Basic insulation is required between power connection components with opposite polarity on the power supply side of the overcurrent protection device.

Overcurrent protection devices must not be installed in protective conductors. The neutral line of multiphase equipment should not have fuses or single-pole circuit breakers installed and should be installed in accordance with GB19517-2009 requirements.

After disconnecting the power grid, be sure to use a digital multimeter (DMM) in the DC range to Figure 1 check for any residual DC voltage from each line terminal to the grounding stud to ensure safety voltage levels (<5Vdc) before touching the device or any terminal blocks or pins.

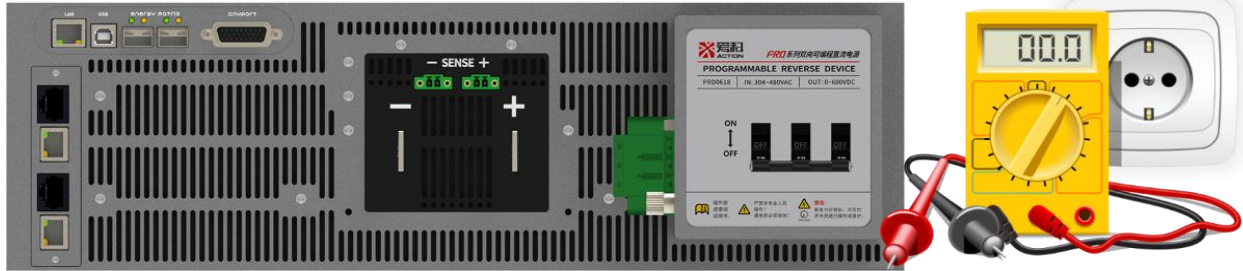

Figure 1 Residual Voltage Check Diagram at Power Supply Port



Warning: Do not replace parts or modify

Due to the risk of introducing additional hazardous materials, do not install substitute parts or make any unauthorized modifications to the equipment. The equipment should be mailed back to the sales service department of Xi'an ActionPower Electric Co., Ltd. for service and repair to ensure proper maintenance.

Equipment that is damaged or defective should be immediately taken out of service and labeled with a sign such as 'Fault/To be Repaired', to prevent accidental operation until it is repaired by professional maintenance personnel.



Note: Instrument Location

Do not place this instrument in any location that obstructs the power disconnect device, or in any manner that makes the power disconnect device difficult to operate.



Note: Please keep the product surface clean and dry.



Note: Do not place heavy objects on the device enclosure.



Note: Avoid severe impacts or improper handling that may cause machine damage.



Note: Do not block the ventilation openings on the side, front, and rear panels.



Warning: To prevent fire, only use fuses of the specified specifications for this product.



Note: Maintenance and Cleaning

Do not perform maintenance and cleaning on this product while it is powered on, as there is a risk of electric shock. Use a soft cloth dampened with mild detergent and water. do not spray the cleaner directly. Do not use chemical or abrasive-containing cleaning products, such as benzene, toluene, xylene, and acetone.

Non-professionals should not perform repair and maintenance cleaning on this product, as it may cause personal injury or equipment damage.



10 minutes

Warning: Wait 10 minutes after power off before opening the enclosure for operation or maintenance.

This product is internally designed with electrolytic capacitors, which have a long discharge time after power off. Therefore, professionals need to discharge the electrolytic capacitors after power off or wait until 10 minutes later when the voltage drops to a safe level before performing operation or maintenance to prevent electric shock accidents caused by residual voltage.

3 Product Overview

This chapter mainly describes the general working characteristics of this product.

3.1 Basic Description

This product integrates power supply and load into one, allowing seamless switching between the two, naturally crossing zero at the power zero-crossing point, which can simplify power configuration and system complexity. At the same time, it is also a high-precision, high-dynamic, and user-friendly regenerative DC programmable source/load product. It features industry-leading power density, an independent high-precision measurement system, and excellent industry load adaptability.

This product has an energy recovery function, capable of feeding DC-side energy back to the power grid with an efficiency of up to 95%.

In addition to basic source/load functions, this product also has a built-in function generator, programming capabilities, and supports sine wave, square wave, triangle wave, and custom waveforms. It also features waveform point editing and supports USB import/export.

The rear panel of this product is equipped with USB and Ethernet interfaces for remote control, and it can also be controlled using an analog interface.

This product can be equipped with a built-in interface module, Magic-Bus, to expand standard industrial buses such as RS232,

RS485, and CAN.

This product is equipped with a matrix high-speed optical fiber digital parallel system, which can combine up to 100 units into a complete system, forming a total power of up to 3000 kW. The system after parallel connection can still meet the performance of accuracy of voltage and current of a single unit.

For detailed performance parameters of this product, see “ 3.5 Parameters” section. These data are typical values obtained under conditions of ambient temperature of 20°C-30°C, rated input, rated output, and resistive load.

Note: The bidirectional characteristics described above are only applicable to CD-B series products.

3.2 Product Appearance

The external appearance of this product is a standard 19-inch structure, which can be placed in a standard cabinet system or on a desktop. Its external dimensions are shown in Figure 2 and Figure 3.



Figure 2 CD-B External Dimensions Diagram



Figure 3 CD-A External Dimensions Diagram

3.3 Product Features

Up to 6 1/2-digit setting and measurement system.

Voltage/current accuracy up to mV/mA level.

Power resolution up to 1W.

Dynamic response time at the hundred us level.

Parallel expansion up to 3MW capacity.

Intelligent Magic-Box and Magic-Bus modules quickly adapt to various industry standards.

3.4 Function Block Diagram

This product uses high-frequency power conversion devices to elevate performance metrics to a new level, Figure 4 The function block diagram of this product is shown.

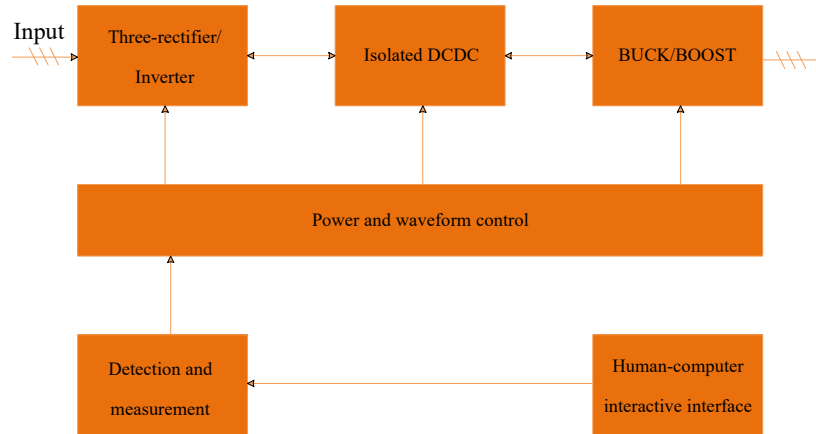

q

Figure 4 Product Function Block Diagram

3.5 Technical Specifications

As follows Table 1 the data listed under ambient temperature of $25^{\circ}\text{C}\pm 5^{\circ}\text{C}$, rated input, and resistive load conditions can serve as a general selection reference.

Table 1 Technical Specifications

Parameter	Mode	30kW Model/30kW Model	
		CD30-1K5B	CD30-2K0B
AC Supply			
Rated Input Voltage Range		380Vac~440Vac	
Input Voltage Range		304Vac~480Vac	
Frequency		47Hz ~ 63Hz	
Connection		3ph+PE	
Inrush Current		<50A	
Efficiency		~ 95%	
Power Factor		~ 0.99	
DC terminal			
Max.Voltage(F.S.)		1500V	2000V
Max.Current(F.S.)		±60A	±60A
Max.Power(F.S.)		±30kW	±30kW
OverVoltage Protection Range		0 ~ Rated 110% (±1% F.S.)	

Parameter	Mode	
	30kW Model/30kW Model	CD30-2K0B
OverCurrent Protection Range	0 ~ Rated $\pm 110\%$ ($\pm 1\%$ F.S.)	
OverPower Protection Range	0 ~ Rated $\pm 110\%$ ($\pm 1\%$ F.S.)	
Voltage regulation		
Adjustment Range	0-1550V	0-2050V
Setting Accuracy (at 25°C $\pm 5^\circ$ C)	$\pm 0.02\%$ F.S.	
Setting Resolution (at 25°C $\pm 5^\circ$ C)	± 100 mV	
Display Accuracy (at 25°C $\pm 5^\circ$ C)	$\pm 0.02\%$ F.S.	
Display Resolution (at 25°C $\pm 5^\circ$ C)	100mV	10mV
Line Regulation ($\pm 10\%$ Uac)	$\pm 0.01\%$ F.S.	
Load Regulation (0V~100%F.S.) ΔI_{OUT}	$\pm 0.01\%$ F.S.	
Remote sensing compensation	Max.Voltage and 2%F.S. ± 1 V	
Rise time (10-90%) F.S.	800 μ s	
Transient time after (50%F.S.)	Return to steady state within 600 μ s $\pm 0.75\%$ F.S. range, 50% to 100% or 100% to 50% load variation	
Ripple(peak)@20MHz bandwidth	2.4Vpp	2.4Vpp

Parameter	Mode	
	30kW Model/30kW Model	CD30-2K0B
Ripple(rms)@300kHz LF	0.4Vrms	0.4Vrms
Discharge time without load	10-30s	
Slew rate (Without load)	3kV/ms	
Slew rate (Full load)	1.5kV/ms	
Current regulation		
Adjustment Range	0-±63A	0-±63A
Setting Accuracy (at 25°C±5°C)	± 0.02%F.S.	
Setting Regulation (at 25°C±5°C)	± 10mA	
Display Accuracy (at 25°C±5°C)	± 0.02%F.S.	
Display Resolution (at 25°C±5°C)	±10mA	
Line Regulation (±10% Uac)	± 0.01%F.S.	
Load Regulation (0V~100%F.S.) ΔUOUT	± 0.05%F.S.	
Rise time (10-90%) F.S.	500μs	
Power regulation		
Adjustment Range	0-30kW	0-30kW

Parameter	Mode	30kW Model/30kW Model	
		CD30-1K5B	CD30-2K0B
Setting Accuracy (at 25°C±5°C)		± 30W	
Setting Resolution (at 25°C±5°C)		± 1W	
Display Accuracy (at 25°C±5°C)		± 30W	
Display Resolution (at 25°C±5°C)		± 1W	
Resistor regulation			
Adjustment Range		0.5-3000Ω	
Setting Accuracy (at 25°C±5°C)		0.1Ω	
Setting Resolution (at 25°C±5°C)		0.1Ω	
Display Accuracy (at 25°C±5°C)		0.1Ω	
Display Resolution (at 25°C±5°C)		0.1Ω	
Anyport			
Signals		See "Anyport interface specification"	
Isolation		707VDC	
Interface/Interfaces			
Rear		Type-B USB、LAN、Share Bus、Magic-BUS、Magic-BOX DC terminal、AC supply、Remote sensing、Analog interface	

Parameter	Mode	30kW Model/30kW Model	
		CD30-1K5B	CD30-2K0B
Front		Type-A USB、ON/OFF Button、Out Button、Touch screen、Rotary knob	
Ambient			
Operation temperature		0 ° C~50°C (Power derating above 35°C)	
Storage temperature		-20 °C~70 °C	
Humidity		≤80%. Not condensing	
Altitude		When above 2000m, output current derates 2%/100m or Ta derates 1°C/100m	
Safety			
Standards		EN 61010-1:2010/A1:2019	
EMC		EN IEC 61326-1:2021	
Insulation			
Negative DC to PE		±1500V DC	
Positive DC to PE		+2000 DC	
AC input <-> PE		2.5 kV AC	
Others/			
Dimensions		W435mm x H132mm x D670 mm(770mm With Breaker)	

Parameter	Mode	30kW Model/30kW Model	
		CD30-1K5B	CD30-2K0B
Weight		35kg	
*Internal resistance accuracy test conditions are $\leq 1\Omega$			

Parameter	Mode	30kW Model/30kW Model	
		CD30-1K5A	CD30-2K0A
AC Supply			
Rated Input Voltage Range		380Vac~440Vac	
Input Voltage Range		304Vac~480Vac	
Frequency		47Hz ~ 63Hz	
Connection		3ph+PE	
Inrush Current		<50A	
Efficiency		~ 95%	
Power Factor		~ 0.99	
DC terminal			
Max.Voltage(F.S.)		1500V	2000V
Max.Current(F.S.)		±60A	±60A
Max.Power(F.S.)		±30kW	±30kW
OverVoltage Protection Range		0 ~ Rated 110% (±1% F.S.)	
OverCurrent Protection Range		0 ~ Rated ±110% (±1% F.S.)	

Parameter	Mode	
	30kW Model/30kW Model	
	CD30-1K5A	CD30-2K0A
OverPower Protection Range	0 ~ Rated $\pm 110\%$ ($\pm 1\%$ F.S.)	
Voltage regulation		
Adjustment Range	0-1550V	0-2050V
Setting Accuracy (at 25°C $\pm 5^\circ$ C)	$\pm 0.02\%$ F.S.	
Setting Resolution (at 25°C $\pm 5^\circ$ C)	± 100 mV	
Display Accuracy (at 25°C $\pm 5^\circ$ C)	$\pm 0.02\%$ F.S.	
Display Resolution (at 25°C $\pm 5^\circ$ C)	100mV	10mV
Line regulation ($\pm 10\%$ Uac)	$\pm 0.01\%$ F.S.	
Load regulation(0V~100%F.S.) Δ IOUT	$\pm 0.01\%$ F.S.	
Remote sensing compensation	Max.Voltage and 2%F.S. ± 1 V	
Rise time (10-90%)F.S.	800 μ s	
Transient time after (50%F.S.)	Return to steady state within 600 μ s $\pm 0.75\%$ F.S. range, 50% to 100% or 100% to 50% load variation	
Ripple(peak)@20MHz bandwidth	2.4Vpp	2.4Vpp
Ripple(rms)@300kHz LF	0.4Vrms	0.4Vrms
Discharge time without load	10-30s	

Parameter	Mode	
	30kW Model/30kW Model	
	CD30-1K5A	CD30-2K0A
Slew rate (Without load)	3kV/ms	
Slew rate (Full load)	1.5kV/ms	
Current regulation		
Adjustment Range	0-±63A	0-±63A
Setting Accuracy (at 25°C±5°C)	± 0.02%F.S.	
Setting Resolution (at 25°C±5°C)	±10mA	
Display Accuracy (at 25°C±5°C)	± 0.02%F.S.	
Display Resolution (at 25°C±5°C)	±10mA	
Line regulation (±10% Uac)	± 0.01%F.S.	
Load regulation(0V-100%F.S.) ΔUOUT	± 0.05%F.S.	
Rise time (10-90%)F.S.	500μs	
Power regulation		
Adjustment Range	0-30kW	0-30kW
Setting Accuracy (at 25°C±5°C)	± 30W	
Setting Resolution (at 25°C±5°C)	± 1W	
Display Accuracy (at 25°C±5°C)	± 30W	

Parameter	Mode	30kW Model/30kW Model	
		CD30-1K5A	CD30-2K0A
Display Resolution (at 25°C±5°C)		± 1W	
Resistor regulation			
Adjustment Range		0.5-3000Ω	
Setting Accuracy (at 25°C±5°C)		0.1Ω	
Setting Resolution (at 25°C±5°C)		0.1Ω	
Display Accuracy (at 25°C±5°C)		0.1Ω	
Display Resolution (at 25°C±5°C)		0.1Ω	
Anyport			
Signals		See "Anyport interface specification"	
Isolation		707VDC	
Interface/Interfaces			
Rear		Type-B USB、LAN、Share Bus、Magic-BUS、Magic-BOX DC terminal、AC supply、Remote sensing、Analog interface	
Front		Type-A USB、ON/OFF Button、Out Button、Touch screen、Rotary knob	
Ambient			
Operation temperature		0 ° C~50°C (Power derating above 35°C)	

Parameter	Mode	30kW Model/30kW Model	
		CD30-1K5A	CD30-2K0A
Storage temperature		-20 °C~70 °C	
Humidity		≤ 80%. Not condensing	
Altitude		When above 2000m, output current derates 2%/100m or Ta derates 1°C/100m	
Safety			
Standards		EN 61010-1:2010/A1:2019	
EMC		EN IEC 61326-1:2021	
Insulation			
Negative DC to PE		±1500 V DC	
Positive DC to PE		+2000 V DC	
AC input <-> PE		2.5 kV AC	
Others			
Dimensions		W435mm x H132mm x D670 mm(770mm With Breaker)	
weight		35kg	
*Internal resistance accuracy test conditions are ≤1Ω			

Parameter	20kW Model/20kW Model		15kW Model/15kW Model	
	CD20-1K5B	CD20-2K0B	CD15-1K5B	CD15-2K0B
AC Supply				
Rated Input Voltage Range	380Vac~440Vac			
Input Voltage Range	304Vac~480Vac			
Frequency	47Hz ~ 63Hz			
Connection	3ph+PE			
Inrush Current	<50A			
Efficiency	~ 94%			
Power Factor	~ 0.99			
DC terminal				
Max.Voltage(F.S.)	1500V	2000V	1500V	2000V
Max.Current(F.S.)	±60A	±60A	±45A	±45A
Max.Power(F.S.)	±20kW	±20kW	±15kW	±15kW
OverVoltage Protection Range	0 ~ Rated 110% (±1% F.S.)			
OverCurrent Protection Range	0 ~ Rated ±110% (±1% F.S.)			

Parameter	Mode	20kW Model/20kW Model		15kW Model/15kW Model	
		CD20-1K5B	CD20-2K0B	CD15-1K5B	CD15-2K0B
OverPower Protection Range		0 ~ Rated $\pm 110\%$ ($\pm 1\%$ F.S.)			
Voltage regulation					
Adjustment Range		0-1550V	0-2050V	0-1550V	0-2050V
Setting Accuracy (at 25°C \pm 5°C)		$\pm 0.02\%$ F.S.			
Setting Resolution (at 25°C \pm 5°C)		$\pm 100\text{mV}$			
Display Accuracy (at 25°C \pm 5°C)		$\pm 0.02\%$ F.S.			
Display Resolution (at 25°C \pm 5°C)		100mV			
Line regulation ($\pm 10\%$ Uac)		$\pm 0.01\%$ F.S.			
Load regulation(0V~100%F.S.) ΔI_{OUT}		$\pm 0.01\%$ F.S.			
Remote sensing compensation		Max.Voltage and 2%F.S. $\pm 1\text{V}$			
Rise time (10-90%) F.S.		800 μs			
Transient time after (50%F.S.)		Return to steady state within 600 μs $\pm 0.75\%$ F.S. range, 50% to 100% or 100% to 50% load variation			
Ripple(peak)@20MHz bandwidth		2.4Vpp			
Ripple(rms)@300kHz LF		0.4Vrms			
Discharge time without load		10-30s			

Parameter \ Mode	20kW Model/20kW Model		15kW Model/15kW Model	
	CD20-1K5B	CD20-2K0B	CD15-1K5B	CD15-2K0B
Slew rate (Without load)	3kV/ms			
Slew rate (Full load)	1.5kV/ms			
Current regulation				
Adjustment Range	0-63A	0-63A	0-42A	0-42A
Setting Accuracy (at 25°C±5°C)	± 0.02%F.S.			
Setting Resolution (at 25°C±5°C)	±10mA			
Display Accuracy (at 25°C±5°C)	± 0.02%F.S.			
Display Resolution (at 25°C±5°C)	±10mA			
Line regulation (±10% Uac)	± 0.01%F.S.			
Load regulation(0V-100%F.S.) ΔUOUT	± 0.05%F.S.			
Rise time (10-90%) F.S.	500μs			
Power regulation				
Adjustment Range	0-20kW	0-20kW	0-15kW	0-15kW
Setting Accuracy (at 25°C±5°C)	± 30W			
Setting Resolution (at 25°C±5°C)	± 1W			
Display Accuracy (at 25°C±5°C)	± 30W			

Parameter	Mode	20kW Model/20kW Model		15kW Model/15kW Model	
		CD20-1K5B	CD20-2K0B	CD15-1K5B	CD15-2K0B
Display Resolution (at 25°C±5°C)	± 1W				
Resistor regulation					
Adjustment Range	0.5-3000Ω				
Setting Accuracy (at 25°C±5°C)	0.1Ω				
Setting Resolution (at 25°C±5°C)	0.1Ω				
Display Accuracy (at 25°C±5°C)	0.1Ω				
Display Resolution (at 25°C±5°C)	0.1Ω				
Anyport					
Signals	See "Anyport interface specification"				
Isolation	707VDC				
Interfaces					
Rear	Type-B USB、LAN、Share Bus、Magic-BUS、Magic-BOX DC terminal、AC supply、Remote sensing、Analog interface				
Front	Type-A USB、ON/OFF Button、Out Button、Touch screen、Rotary knob				
Ambient					
Operation temperature	0 ° C~50°C (Power derating above 35°C)				

Parameter	Mode	20kW Model/20kW Model		15kW Model/15kW Model	
		CD20-1K5B	CD20-2K0B	CD15-1K5B	CD15-2K0B
Storage temperature	-20 °C~70 °C				
Humidity	≤ 80%. Not condensing				
Altitude	When above 2000m, output current derates 2%/100m or Ta derates 1°C/100m				
Safety					
Standards	EN61010-1:2010/A1:2019				
EMC	IEC/EN 61326-1: 2021				
Insulation					
Negative DC to PE	±1500 V DC				
Positive DC to PE	+2000 V DC				
AC input <-> PE	2.5 kV AC				
Others					
Dimensions	W435mm x H132mm x D670 mm(770mm With Breaker)				
weight	35kg				
*Internal resistance accuracy test conditions are ≤1Ω					

Parameter	Mode		20kW Model/20kW Model		15kW Model/15kW Model	
	CD20-1K5A	CD20-2K0A	CD15-1K5A	CD15-2K0A		
AC Supply						
Rated Input Voltage Range	380Vac~440Vac					
Input Voltage Range	304Vac~480Vac					
Frequency	47Hz ~ 63Hz					
Connection	3ph+PE					
Inrush Current	<50A					
Efficiency	~ 94%					
Power Factor	~ 0.99					
DC Parameters/DC terminal						
Max.Voltage(F.S.)	1500V	2000V	1500V	2000V		
Max.Current(F.S.)	60A	60A	45A	45A		
Max.Power(F.S.)	20kW	20kW	15kW	15kW		
OverVoltage Protection Range	0V ~ Rated 110% (±1%F.S.)					
OverCurrent Protection Range	0V ~ Rated 110% (±1%F.S.)					

Parameter	Mode		20kW Model/20kW Model		15kW Model/15kW Model	
	CD20-1K5A	CD20-2K0A	CD15-1K5A	CD15-2K0A	CD15-1K5A	CD15-2K0A
OverPower Protection Range	0V ~ Rated 110% ($\pm 1\%$ F.S.)					
Voltage regulation						
Adjustment Range	0-1550V	0-2050V	0-1550V	0-2050V	0-1550V	0-2050V
Setting Accuracy (at 25°C $\pm 5^\circ$ C)	$\pm 0.02\%$ F.S.					
Setting Resolution (at 25°C $\pm 5^\circ$ C)	± 100 mV					
Display Accuracy (at 25°C $\pm 5^\circ$ C)	$\pm 0.02\%$ F.S.					
Display Resolution (at 25°C $\pm 5^\circ$ C)	100mV					
Line regulation ($\pm 10\%$ Uac)	$\pm 0.01\%$ F.S.					
Load regulation(0V~100%F.S.) Δ IOUT	$\pm 0.01\%$ F.S.					
Remote sensing compensation	Max.Voltage and 2%F.S. ± 1 V					
Rise time (10-90%) F.S.	800 μ s					
Transient time after (50%F.S.)	Return to steady state within 600 μ s $\pm 0.75\%$ F.S. range, 50% to 100% or 100% to 50% load variation					
Ripple(peak)@20MHz bandwidth	2.4Vpp					
Ripple(rms)@300kHz LF	0.4Vrms					
Discharge time without load	10-30s					

Parameter	Mode	20kW Model/20kW Model		15kW Model/15kW Model	
		CD20-1K5A	CD20-2K0A	CD15-1K5A	CD15-2K0A
Slew rate (Without load)	3kV/ms				
Slew rate (Full load)	1.5kV/ms				
Current regulation					
Adjustment Range	0-63A	0-63A	0-42A	0-42A	
Setting Accuracy (at 25°C±5°C)	± 0.02%F.S.				
Setting Resolution (at 25°C±5°C)	±10mA				
Display Accuracy (at 25°C±5°C)	± 0.02%F.S.				
Display Resolution (at 25°C±5°C)	10mA				
Line regulation (±10% Uac)	± 0.01%F.S.				
Load regulation(0V~100%F.S.) ΔUOUT	± 0.05%F.S.				
Rise time (10-90%) F.S.	500μs				
Power regulation					
Adjustment Range	0-20kW	0-20kW	0-15kW	0-15kW	
Setting Accuracy (at 25°C±5°C)	± 30.				
Setting Resolution (at 25°C±5°C)	± 1W				
Display Accuracy (at 25°C±5°C)	± 3W				

Parameter	Mode	20kW Model/20kW Model		15kW Model/15kW Model	
		CD20-1K5A	CD20-2K0A	CD15-1K5A	CD15-2K0A
Display Resolution (at 25°C±5°C)	± 1W				
Resistor regulation					
Adjustment Range	0.5-3000Ω				
Setting Accuracy (at 25°C±5°C)	0.1Ω				
Setting Resolution (at 25°C±5°C)	0.1Ω				
Display Accuracy (at 25°C±5°C)	0.1Ω				
Display Resolution (at 25°C±5°C)	0.1Ω				
Anyport					
Signals	See"Anyport interface specification"				
Isolation	707VDC				
Interfaces					
Rear	Type-B USB、LAN、Share Bus、Magic-BUS、Magic-BOX DC terminal、AC supply、Remote sensing、Analog interface				
Front	Type-A USB、ON/OFF Button、Out Button、Touch screen、Rotary knob				
Ambient					
Operation temperature	0 ° C~50°C (Power derating above 35°C)				

Parameter	Mode	20kW Model/20kW Model		15kW Model/15kW Model	
		CD20-1K5A	CD20-2K0A	CD15-1K5A	CD15-2K0A
Storage temperature	-20 °C~70 °C				
Humidity	≤ 80%. Not condensing				
Altitude	When above 2000m, output current derates 2%/100m or Ta derates 1°C/100m				
Safety					
Standards	EN61010-1:2010/A1:2019				
EMC	IEC/EN 61326-1: 2021				
Insulation					
Negative DC to PE	±1500 V DC				
Positive DC to PE	+2000 V DC				
AC input <-> PE	2.5 kV AC				
Others					
Dimensions	W435mm x H132mm x D670 mm (770mm With Breaker)				
weight	35kg				
*Internal resistance accuracy test conditions are ≤1Ω					

Mode Parameter	30kW Model/30kW Model	
	CD30-800B	CD30-1K0B
AC Supply		
Rated Input Voltage Range	380Vac~440Vac	
Input Voltage Range	304Vac~480Vac	
Frequency	47Hz ~ 63Hz	
Connection	3ph+PE	
Inrush Current	<50A	
Efficiency	~ 94%	
Power Factor	~ 0.99	
DC terminal		
Max.Voltage(F.S.)	800V	1000V
Max.Current(F.S.)	±80A	
Max.Power(F.S.)	±30kW	
OverVoltage Protection Range	0V ~ Rated 110% (±1%F.S.)	
OverCurrent Protection Range	0V ~ Rated ±110% (±1%F.S.)	

Mode Parameter	30kW Model/30kW Model	
	CD30-800B	CD30-1K0B
OverPower Protection Range	0V ~ Rated $\pm 110\%$ ($\pm 1\%$ F.S.)	
Voltage regulation		
Adjustment Range	0-820V	0-1020V
Setting Accuracy (at 25°C $\pm 5^\circ\text{C}$)	$\pm 0.02\%$ F.S.	
Setting Resolution (at 25°C $\pm 5^\circ\text{C}$)	$\pm 50\text{mV}$	
Display Accuracy (at 25°C $\pm 5^\circ\text{C}$)	$\pm 0.02\%$ F.S.	
Display Resolution (at 25°C $\pm 5^\circ\text{C}$)	50mV	
Line regulation ($\pm 10\%$ Uac)	$\pm 0.01\%$ F.S.	
Load regulation(0V~100%F.S.) ΔIOUT	$\pm 0.01\%$ F.S.	
Remote sensing compensation	Max.Voltage and 2%F.S. $\pm 1\text{V}$	
Rise time (10-90%) F.S.	800 μs	
Transient time after (50%F.S.)	Return to steady state within 600 μs $\pm 0.75\%$ F.S. within range, 10% to 60% or 60% to 10% load variation	

Mode Parameter	30kW Model/30kW Model	
	CD30-800B	CD30-1K0B
Ripple(peak)@20MHz bandwidth	1.2Vpp	
Ripple(rms)@300kHz	0.2Vrms	
LF Discharge Time without load	≤20s	
Slew rate (Without load)	1.5KV/ms	
Slew rate (Full load)	1KV /ms	
Current regulation		
Adjustment Range	0-±84A	
Setting Accuracy (at 25°C±5°C)	± 0.02%F.S.	
Setting Resolution (at 25°C±5°C)	± 10mA	
Display Accuracy (at 25°C±5°C)	± 0.02%F.S.	
Display Resolution (at 25°C±5°C)	10mA	
Line regulation (±10% Uac)	± 0.01%F.S.	
Load regulation(0V~100%F.S.) ΔUOUT	± 0.05%F.S.	

Mode Parameter	30kW Model/30kW Model	
	CD30-800B	CD30-1K0B
Rise time (10-90%) F.S.	500μs	
Power regulation		
Adjustment Range	0-30kW	
Setting Accuracy (at 25°C±5°C)	± 30W	
Setting Resolution (at 25°C±5°C)	± 1W	
Display Accuracy (at 25°C±5°C)	± 30W	
Display Resolution (at 25°C±5°C)	± 1W	
Resistor regulation		
Adjustment Range	0.05-100Ω	
Setting Accuracy (at 25°C±5°C)	0.01Ω	
Setting Resolution (at 25°C±5°C)	0.01Ω	
Display Accuracy (at 25°C±5°C)	0.01Ω	
Display Resolution (at 25°C±5°C)	0.01Ω	
Anyport		

Mode Parameter	30kW Model/30kW Model	
	CD30-800B	CD30-1K0B
Signals	See "Anyport interface specification"	
Isolation	707VDC	
Interfaces		
Rear	Type-B USB、LAN、Share Bus、Magic-BUS、Magic-BOX DC terminal、AC supply、Remote sensing、Analog interface	
Front	Type-A USB、ON/OFF Button、Out Button、Touch screen、Rotary knob	
Ambient		
Operation temperature	0 ° C~50°C (Power derating above 35°C)	
Storage temperature	-20 °C~70 °C	
Humidity	≤ 80%. Not condensing	
Altitude	When above 2000m, output current derates 2%/100m or Ta derates 1°C/100m	
Safety		
Standards	EN61010-1:2010/A1:2019	
Electromagnetic Compatibility/EMC	IEC/EN 61326-1: 2021	

Mode Parameter	30kW Model/30kW Model	
	CD30-800B	CD30-1K0B
Insulation		
Negative DC to PE	±1500 V DC	
Positive DC to PE	+1500 V DC	
AC input <-> PE	2.5 kV AC	
Others		
Dimensions	W435mm x H132mm x D670 mm (770mm With Breaker)	
weight	35kg	
*Internal resistance accuracy test conditions are $\leq 1\Omega$		

Mode Parameter	30kW Model/30kW Model	
	CD30-800A	CD30-1K0A
AC Supply		
Rated Input Voltage Range	380Vac~440Vac	
Input Voltage Range	304Vac~480Vac	
Frequency	47Hz ~ 63Hz	
Connection	3ph+PE	
Inrush Current	<50A	
Efficiency	~ 95%	
Power Factor	~ 0.99	
DC terminal		
Max.Voltage(F.S.)	800V	1000V
Max.Current(F.S.)	80A	
Max.Power(F.S.)	30kW	
OverVoltage Protection Range	0V ~ Rated 110% ($\pm 1\%$ F.S.)	
OverCurrent Protection Range	0V ~ Rated 110% ($\pm 1\%$ F.S.)	

Mode Parameter	30kW Model/30kW Model	
	CD30-800A	CD30-1K0A
OverPower Protection Range	0V ~ Rated 110% ($\pm 1\%$ F.S.)	
Voltage regulation		
Adjustment Range	0-820V	0-1020V
Setting Accuracy (at 25°C $\pm 5^\circ$ C)	$\pm 0.02\%$ F.S.	
Setting Resolution (at 25°C $\pm 5^\circ$ C)	± 50 mV	
Display Accuracy (at 25°C $\pm 5^\circ$ C)	$\pm 0.02\%$ F.S.	
Display Resolution (at 25°C $\pm 5^\circ$ C)	50mV	
Line regulation ($\pm 10\%$ Uac)	$\pm 0.01\%$ F.S.	
Load regulation(0V~100%F.S.) Δ IOUT	$\pm 0.01\%$ F.S.	
Remote sensing compensation	Max.Voltage and 2%F.S. ± 1 V	
Rise time (10-90%) F.S.	800 μ s	
Transient time after (25%F.S.)	Return to steady state within 600 μ s $\pm 0.75\%$ F.S. within range, 25% to 50% or 50% to 25% load variation	

Mode Parameter	30kW Model/30kW Model	
	CD30-800A	CD30-1K0A
Ripple(peak)@20MHz bandwidth	1.2Vpp	
Ripple(rms)@300kHz LF	0.2Vrms	
Discharge time without load	≤20s	
Slew rate (Without load)	1.5kV/ms	
Slew rate (Full load)	1kV/ms	
Current regulation		
Adjustment Range	0-84A	
Setting Accuracy (at 25°C±5°C)	± 0.02%F.S.	
Setting Resolution (at 25°C±5°C)	± 10mA	
Display Accuracy (at 25°C±5°C)	± 0.02%F.S.	
Display Resolution (at 25°C±5°C)	10mA	
Line regulation (±10% Uac)	± 0.01%F.S.	
Load regulation(0V~100%F.S.) ΔUOUT	± 0.05%F.S.	

Mode Parameter	30kW Model/30kW Model	
	CD30-800A	CD30-1K0A
Rise time (10-90%) F.S.	500μs	
Power regulation		
Adjustment Range	0-30kW	
Setting Accuracy (at 25°C±5°C)	±30W	
Setting Resolution (at 25°C±5°C)	± 1W	
Display Accuracy (at 25°C±5°C)	± 30W	
Display Resolution (at 25°C±5°C)	± 1W	
Resistor regulation		
Adjustment Range	0.05-100Ω	
Setting Accuracy (at 25°C±5°C)	0.01Ω	
Setting Resolution (at 25°C±5°C)	0.01Ω	
Display Accuracy (at 25°C±5°C)	0.01Ω	
Display Resolution (at 25°C±5°C)	0.01Ω	
Anyport		

Mode Parameter	30kW Model/30kW Model	
	CD30-800A	CD30-1K0A
Signals	See "Anyport interface specification"	
Isolation	707VDC	
Interfaces		
Rear	Type-B USB、LAN、Share Bus、Magic-BUS、Magic-BOX DC terminal、AC supply、Remote sensing、Analog interface	
Front	Type-A USB、ON/OFF Button、Out Button、Touch screen、Rotary knob	
Ambient		
Operation temperature	0 ° C~50°C (Power derating above 35°C)	
Storage temperature	-20 °C~70 °C	
Humidity	≤ 80%. Not condensing	
Altitude	When above 2000m, output current derates 2%/100m or Ta derates 1°C/100m	
Safety		
Standards	EN61010-1:2010/A1:2019	
EMC	IEC/EN 61326-1: 2021	
Insulation		

Mode Parameter	30kW Model/30kW Model	
	CD30-800A	CD30-1K0A
Negative DC to PE	±1500 V DC	
Positive DC to PE	+1500 V DC	
AC input <-> PE	2.5 kV AC	
Others		
Dimensions	W435mm x H132mm x D670 mm(770mm With Breaker)	
Weight	35kg	
*Internal resistance accuracy test conditions are $\leq 1\Omega$		

Parameter	20kW Model/20kW Model		15kW Model/15kW Model	
	CD20-1K0B	CD20-800B	CD15-1K0B	CD15-800B
AC Supply				
Rated Input Voltage Range	380Vac~440Vac			
Input Voltage Range	304Vac~480Vac			
Frequency	47Hz ~ 63Hz			
Connection	3ph+PE			
Inrush Current	<50A			
Efficiency	~ 94%			
Power Factor	~ 0.99			
DC terminal				
Max.Voltage(F.S.)	1000V	800V	1000V	800V
Max.Current(F.S.)	±80A	±80A	±54A	±54A
Max.Power(F.S.)	±20kW	±20kW	±15kW	±15kW
OverVoltage Protection Range	0 ~ Rated 110% (±1% F.S.)			

Parameter \ Mode	20kW Model/20kW Model		15kW Model/15kW Model	
	CD20-1K0B	CD20-800B	CD15-1K0B	CD15-800B
OverCurrent Protection Range	0 ~ Rated $\pm 110\%$ ($\pm 1\%$ F.S.)			
OverPower Protection Range	0 ~ Rated $\pm 110\%$ ($\pm 1\%$ F.S.)			
Voltage regulation				
Adjustment Range	0-1020V	0-820V	0-1020V	0-820V
Setting Accuracy (at 25°C $\pm 5^\circ$ C)	$\pm 0.02\%$ F.S.			
Setting Resolution (at 25°C $\pm 5^\circ$ C)	± 50 mV			
Display Accuracy (at 25°C $\pm 5^\circ$ C)	$\pm 0.02\%$ F.S.			
Display Resolution (at 25°C $\pm 5^\circ$ C)	± 50 mV			
Line regulation ($\pm 10\%$ Uac)	$\pm 0.01\%$ F.S.			
Load regulation(0V~100%F.S.) Δ IOUT	$\pm 0.01\%$ F.S.			
Remote sensing compensation	Max.Voltage and 2%F.S. ± 1 V			
Rise time (10-90%) F.S.	500 μ s			
Transient time after (50%F.S.)	Return to steady state within 500 μ s $\pm 0.75\%$ F.S. within range, 10% to 60% or 60% to 10% load variation			
Ripple(peak)@20MHz bandwidth	1.2Vpp			

Parameter \ Mode	20kW Model/20kW Model		15kW Model/15kW Model	
	CD20-1K0B	CD20-800B	CD15-1K0B	CD15-800B
Ripple(rms)@300kHz LF	0.2Vrms			
Discharge time without load	≤20s			
Slew rate (Without load)	1.5kV/ms			
Slew rate (Full load)	1kV/ms			
Current regulation				
Adjustment Range	0-±84A	0-±84A	0-±56.7A	0-±56.7A
Setting Accuracy (at 25°C±5°C)	± 0.02%F.S.			
Setting Resolution (at 25°C±5°C)	± 10mA			
Display Accuracy (at 25°C±5°C)	± 0.02%F.S.			
Display Resolution (at 25°C±5°C)	± 10mA			
Line regulation (±10% Uac)	± 0.01%F.S.			
Load regulation(0V~100%F.S.) ΔUOUT	± 0.05%F.S.			
Rise time (10-90%) F.S.	500μs			
Power regulation				
Adjustment Range	0-20kW	0-20kW	0-15kW	0-15kW
Setting Accuracy (at 25°C±5°C)	± 30W			

Parameter \ Mode	20kW Model/20kW Model		15kW Model/15kW Model	
	CD20-1K0B	CD20-800B	CD15-1K0B	CD15-800B
Setting Resolution (at 25°C±5°C)	± 1W			
Display Accuracy (at 25°C±5°C)	± 30W			
Display Resolution (at 25°C±5°C)	± 1W			
Resistor regulation				
Adjustment Range	0.05-100Ω			
Setting Accuracy (at 25°C±5°C)	0.01Ω			
Setting Resolution (at 25°C±5°C)	0.01Ω			
Display Accuracy (at 25°C±5°C)	0.01Ω			
Display Resolution (at 25°C±5°C)	0.01Ω			
Anyport				
Signals	See*Anyport interface specification"			
Isolation	707VDC			
Interfaces				
Rear	Type-B USB、LAN、Share Bus、Magic-BUS、Magic-BOX DC terminal、AC supply、Remote sensing、Analog interface			
Front	Type-A USB、ON/OFF Button、Out Button、Touch screen、Rotary knob			

Parameter	Mode	20kW Model/20kW Model		15kW Model/15kW Model	
		CD20-1K0B	CD20-800B	CD15-1K0B	CD15-800B
Ambient					
Operation temperature	0 ° C~50°C (Power derating above 35°C)				
Storage temperature	-20 °C~70 °C				
Humidity	≤ 80%. Not condensing				
Altitude	When above 2000m, output current derates 2%/100m or Ta derates 1°C/100m				
Safety					
Standards	EN61010-1:2010/A1:2019				
EMC	IEC/EN 61326-1: 2021				
Insulation					
Negative DC to PE	±1500 V DC				
Positive DC to PE	+2000 V DC				
AC input <-> PE	2.5 kV AC				
Others					
Dimensions	W435mm x H132mm x D670 mm(770mm With Breaker)				
weight	35kg				

Parameter	20kW Model/20kW Model		15kW Model/15kW Model	
	CD20-1K0B	CD20-800B	CD15-1K0B	CD15-800B
*Internal resistance accuracy test conditions are $\leq 1\Omega$				

Parameter	20kW Model/20kW Model		15kW Model/15kW Model	
	CD20-1K0A	CD20-800A	CD15-1K0A	CD15-800A
AC Supply				
Voltage Range	380Vac~440Vac			
Voltage Range	304Vac~480Vac			
Frequency	47Hz ~ 63Hz			
Connection	3ph+PE			
Inrush Current	<50A			
Efficiency	~ 94%			
Power Factor	~ 0.99			
DC terminal				
Max.Voltage(F.S.)	1000V	800V	1000V	800V
Max.Current(F.S.)	80A	80A	54A	54A
Max.Power(F.S.)	20kW	20kW	15kW	15kW
OverVoltage Protection Range	0V ~ Rated 110% ($\pm 1\%$ F.S.)			
OverCurrent Protection Range	0V ~ Rated 110% ($\pm 1\%$ F.S.)			

Parameter \ Mode	20kW Model/20kW Model		15kW Model/15kW Model	
	CD20-1K0A	CD20-800A	CD15-1K0A	CD15-800A
OverPower Protection Range	0V ~ Rated 110% ($\pm 1\%$ F.S.)			
Voltage regulation				
Adjustment Range	0-1020V	0-820V	0-1020V	0-820V
Setting Accuracy (at 25°C $\pm 5^\circ$ C)	$\pm 0.02\%$ F.S.			
Setting Resolution (at 25°C $\pm 5^\circ$ C)	± 50 mV			
Display Accuracy (at 25°C $\pm 5^\circ$ C)	$\pm 0.02\%$ F.S.			
Display Resolution (at 25°C $\pm 5^\circ$ C)	50mV			
Line regulation ($\pm 10\%$ Uac)	$\pm 0.01\%$ F.S.			
Load regulation(0V~100%F.S.) Δ IOUT	$\pm 0.01\%$ F.S.			
Remote sensing compensation	Max.Voltage and 2%F.S. ± 1 V			
Rise time (10-90%) F.S.	500 μ s			
Transient time after (50%F.S.)	Return to steady state within 500 μ s $\pm 0.75\%$ F.S. within range, 10% to 60% or 60% to 10% load variation			
Ripple(peak)@20MHz bandwidth	1.2Vpp			
Ripple(rms)@300kHz LF	0.2Vrms			
Discharge time without load	≤ 20 s			

Parameter \ Mode	20kW Model/20kW Model		15kW Model/15kW Model	
	CD20-1K0A	CD20-800A	CD15-1K0A	CD15-800A
Slew rate (Without load)	1.5kV/ms			
Slew rate (Full load)	1kV/ms			
Current regulation				
Adjustment Range	0-84A	0-84A	0-56.7A	0-56.7A
Setting Accuracy (at 25°C±5°C)	± 0.02%F.S.			
Setting Resolution (at 25°C±5°C)	± 10mA			
Display Accuracy (at 25°C±5°C)	± 0.02%F.S.			
Display Resolution (at 25°C±5°C)	1mA			
Line regulation (±10% Uac)	± 0.01%F.S.			
Load regulation(0V~100%F.S.) ΔUOUT	± 0.05%F.S.			
Rise time (10-90%) F.S.	500μs			
Power regulation				
Adjustment Range	0-20kW	0-20kW	0-15kW	0-15kW
Setting Accuracy (at 25°C±5°C)	± 30W			
Setting Resolution (at 25°C±5°C)	± 1W			
Display Accuracy (at 25°C±5°C)	± 30W			

Parameter \ Mode	20kW Model/20kW Model		15kW Model/15kW Model	
	CD20-1K0A	CD20-800A	CD15-1K0A	CD15-800A
Display Resolution (at 25°C±5°C)	± 1W			
Resistor regulation				
Adjustment Range	0.5-3000Ω			
Setting Accuracy (at 25°C±5°C)	0.01Ω			
Setting Resolution (at 25°C±5°C)	0.01Ω			
Display Accuracy (at 25°C±5°C)	0.01Ω			
Display Resolution (at 25°C±5°C)	0.01Ω			
Anyport				
Signals	See "Anyport interface specification"			
Isolation	707VDC			
Interfaces				
Rear	Type-B USB、LAN、Share Bus、Magic-BUS、Magic-BOX DC terminal、AC supply、Remote sensing、Analog interface			
Front	Type-A USB、ON/OFF Button、Out Button、Touch screen、Rotary knob			
Ambient				
Operation temperature	0 ° C-50°C (Power derating above 35°C)			

Parameter \ Mode	20kW Model/20kW Model		15kW Model/15kW Model	
	CD20-1K0A	CD20-800A	CD15-1K0A	CD15-800A
Storage temperature	-20 °C~70 °C			
Humidity	≤ 80%. Not condensing			
Altitude	When above 2000m, output current derates 2%/100m or Ta derates 1°C/100m			
Safety				
Standards	EN61010-1:2010/A1:2019			
EMC	IEC/EN 61326-1: 2021			
Insulation				
Negative DC to PE	±1500 V DC			
Positive DC to PE	+2000 V DC			
AC input <-> PE	2.5 kV AC			
Others				
Dimensions	W435mm x H132mm x D670 mm(770mm With Breaker)			
weight	35kg			
*Internal resistance accuracy test conditions are ≤1Ω				

Parameter	20kW Model/20kW Model			15kW Model/15kW Model		
	CD20-040B	CD20-060B	CD20-080B	CD15-040B	CD15-060B	CD15-080B
AC Supply						
Rated Input Voltage Range	380Vac~440Vac					
Input Voltage Range	304Vac~480Vac					
Frequency	47Hz ~ 63Hz					
Connection	3ph+PE					
Inrush Current	<50A					
Efficiency	~ 93.5%					
Power Factor	~ 0.99					
DC terminal						
Max.Voltage(F.S.)	40V	60V	80V	40V	60V	80V
Max.Current(F.S.)	±667A	±667A	±667A	±500A	±500A	±500A
Max.Power(F.S.)	±20kW	±20kW	±20kW	±15kW	±15kW	±15kW
OverVoltage Protection Range	0V ~ Rated 110% (±1%F.S.)					
OverCurrent Protection Range	0V ~ Rated ±110% (±1%F.S.)					
OverPower Protection Range	0V ~ Rated ±110% (±1%F.S.)					

Parameter	20kW Model/20kW Model			15kW Model/15kW Model		
	CD20-040B	CD20-060B	CD20-080B	CD15-040B	CD15-060B	CD15-080B
Voltage regulation						
Adjustment Range	0-42V	0-62V	0-82V	0-42V	0-62V	0-82V
Setting Accuracy (at 25°C±5°C)	± 0.02%F.S.					
Setting Accuracy (at 25°C±5°C)	± 10mV					
Display Accuracy (at 25°C±5°C)	± 0.02%F.S.					
Display Resolution (at 25°C±5°C)	10mV					
Line regulation (±10% Uac)	± 0.01%F.S.					
Load regulation(0V~100%F.S.) ΔIOUT	± 0.01%F.S.					
Remote sensing compensation	Max.Voltage±1V					
Rise time (10-90%) F.S.	2.5ms					
Transient time after (50%F.S.)	Return to steady state within 2.5ms ±0.75%F.S. within range, 10% to 60% or 60% to 10% load variation					
Ripple(peak)@20MHz bandwidth	400mVpp					
Ripple(rms)@300kHz LF	25Vrms					
Discharge time without load	≤20s					
Slew rate (Without load)	50V/ms	50V/ms	50V/ms	50V/ms	50V/ms	50V/ms
Slew rate (Full load)	30V/ms	30V/ms	30V/ms	30V/ms	30V/ms	30V/ms

Parameter	20kW Model/20kW Model			15kW Model/15kW Model		
	CD20-040B	CD20-060B	CD20-080B	CD15-040B	CD15-060B	CD15-080B
Current regulation						
Adjustment Range	0-±680A	0-±680A	0-±680A	0-±680A	0-±680A	0-±680A
Setting Accuracy (at 25°C±5°C)	± 0.1%F.S.					
Setting Resolution (at 25°C±5°C)	± 100mA					
Display Accuracy (at 25°C±5°C)	± 0.1%F.S.					
Display Resolution (at 25°C±5°C)	±10mA					
Line regulation (±10% Uac)	± 0.01%F.S.					
Load regulation(0V~100%F.S.) ΔUOUT	± 0.05%F.S.					
Rise time (10-90%) F.S.	1ms					
Power regulation						
Adjustment Range	0-20kW	0-20kW	0-20kW	0-15kW	0-15kW	0-15kW
Setting Accuracy (at 25°C±5°C)	± 30W					
Setting Resolution (at 25°C±5°C)	± 10W					
Display Accuracy (at 25°C±5°C)	± 30W					
Display Resolution (at 25°C±5°C)	± 10W					
Resistor regulation						

Parameter	Mode	20kW Model/20kW Model			15kW Model/15kW Model		
		CD20-040B	CD20-060B	CD20-080B	CD15-040B	CD15-060B	CD15-080B
Adjustment Range	0.003-100Ω						
Setting Accuracy (at 25°C±5°C)	1mΩ						
Setting Accuracy (at 25°C±5°C)	1mΩ						
Display Accuracy (at 25°C±5°C)	1mΩ						
Display Resolution (at 25°C±5°C)	1mΩ						
Anyport							
Signals	See*Anyport interface specification"						
Isolation	707VDC						
Interfaces							
Rear	Type-B USB、LAN、Share Bus、Magic-BUS、Magic-BOX DC terminal、AC supply、Remote sensing、Analog interface						
Front	Type-A USB、ON/OFF Button、Out Button、Touch screen、Rotary knob						
Ambient							
Operation temperature	0 ° C~50°C (Power derating above 35°C)						
Storage temperature	-20 °C~70 °C						
Humidity	≤ 80%. Not condensing						

Parameter	20kW Model/20kW Model			15kW Model/15kW Model		
	CD20-040B	CD20-060B	CD20-080B	CD15-040B	CD15-060B	CD15-080B
Altitude	When above 2000m, output current derates 2%/100m or Ta derates 1°C/100m					
Safety						
Standards	EN61010-1:2010/A1:2019					
EMC	IEC/EN 61326-1: 2021					
Insulation						
Negative DC to PE	±500 V DC					
Positive DC to PE	+500 V DC					
AC input <-> PE	2.5 kV AC					
Others						
Dimensions	W435mm x H132mm x D670 mm(770mm With Breaker)					
Weight	40kg					
*Internal resistance accuracy test conditions are $\leq 1\Omega$						

Parameter	Mode	20kW Model/20kW Model			15kW Model/15kW Model		
		CD20-040A	CD20-060A	CD20-080A	CD15-040A	CD15-060A	CD15-080A
AC Supply							
Rated Input Voltage Range	380Vac~440Vac						
Input Voltage Range	304Vac~480Vac						
Frequency	47Hz ~ 63Hz						
Connection	3ph+PE						
Inrush Current	<50A						
Efficiency	~ 93.5%						
Power Factor	~ 0.99						
DC terminal							
Max.Voltage(F.S.)	40V	60V	80V	40V	60V	80V	
Max.Current(F.S.)	667A						
Max.Power(F.S.)	20kW			15kW			
OverVoltage Protection Range	0V ~ Rated 110% ($\pm 1\%$ F.S.)						
OverCurrent Protection Range	0V ~ Rated 110% ($\pm 1\%$ F.S.)						
OverPower Protection Range	0V ~ Rated 110% ($\pm 1\%$ F.S.)						

Parameter	Mode	20kW Model/20kW Model			15kW Model/15kW Model		
		CD20-040A	CD20-060A	CD20-080A	CD15-040A	CD15-060A	CD15-080A
Voltage Parameters							
Adjustment Range		0-42V	0-62V	0-82V	0-42V	0-62V	0-82V
Setting Accuracy (at 25°C±5°C)		± 0.02%F.S.					
Setting Resolution (at 25°C±5°C)		± 10mV					
Display Accuracy (at 25°C±5°C)		± 0.02%F.S.					
Display Resolution (at 25°C±5°C)		10mV					
Line regulation (±10% Uac)		± 0.01%F.S.					
Load regulation(0V~100%F.S.) ΔIOUT		± 0.01%F.S.					
Remote sensing compensation		Max.Voltage±1V					
Rise time (10-90%) F.S.		1ms					
Transient time after (50%F.S.)		Return to steady state within 500μs ±0.75%F.S. within range, 10% to 60% or 60% to 10% load variation					
Ripple(peak)@20MHz bandwidth		400mVpp					
Ripple(rms)@300kHz LF		25mVrms					
Discharge time without load		≤20s					
Slew rate (Without load)		50V/ms					
Slew rate (Full load)		30V/ms					

Parameter	Mode	20kW Model/20kW Model			15kW Model/15kW Model		
		CD20-040A	CD20-060A	CD20-080A	CD15-040A	CD15-060A	CD15-080A
Current regulation							
Adjustment Range	0-680A						
Setting Accuracy (at 25°C±5°C)	± 0.1%F.S.						
Setting Resolution (at 25°C±5°C)	± 100mA						
Display Accuracy (at 25°C±5°C)	± 0.1%F.S.						
Display Resolution (at 25°C±5°C)	±10mA						
Line regulation (±10% Uac)	± 0.01%F.S.						
Load regulation(0V~100%F.S.) ΔUOUT	± 0.05%F.S.						
Rise time (10-90%) F.S.	3ms						
Power regulation							
Adjustment Range	0-20kW			0-15kW			
Setting Accuracy (at 25°C±5°C)	± 30W						
Setting Resolution (at 25°C±5°C)	± 10W						
Display Accuracy (at 25°C±5°C)	± 30W						
Display Resolution (at 25°C±5°C)	± 10W						
Resistor regulation							

Parameter	Mode	20kW Model/20kW Model			15kW Model/15kW Model		
		CD20-040A	CD20-060A	CD20-080A	CD15-040A	CD15-060A	CD15-080A
Adjustment Range		0.003-100Ω					
Setting Accuracy (at 25°C±5°C)		1mΩ					
Setting Resolution (at 25°C±5°C)		1mΩ					
Display Accuracy (at 25°C±5°C)		1mΩ					
Display Resolution (at 25°C±5°C)		1mΩ					
Anyport							
Signals		See "Anyport interface specification"					
Isolation		707VDC					
Interfaces							
Rear		Type-B USB、LAN、Share Bus、Magic-BUS、Magic-BOX DC terminal、AC supply、Remote sensing、Analog interface					
Front		Type-A USB、ON/OFF Button、Out Button、Touch screen、Rotary knob					
Ambient							
Operation temperature		0 ° C~50°C (Power derating above 35°C)					
Storage temperature		-20 °C~70 °C					
Humidity		≤ 80%. Not condensing					

Parameter	Mode	20kW Model/20kW Model			15kW Model/15kW Model		
		CD20-040A	CD20-060A	CD20-080A	CD15-040A	CD15-060A	CD15-080A
Altitude	When above 2000m, output current derates 2%/100m or Ta derates 1°C/100m						
Safety							
Standards	EN61010-1:2010/A1:2019						
EMC	IEC/EN 61326-1: 2021						
Insulation							
Negative DC to PE	±500 V DC						
Positive DC to PE	+500 V DC						
AC input <-> PE	2.5 kV AC						
Others							
Dimensions	W435mm x H132mm x D670 mm (770mm With Breaker)						
weight	40kg						
*Internal resistance accuracy test conditions are $\leq 1\Omega$							

The figure shows the power curves of different CD-B models. The vertical axis represents voltage (V). The horizontal axis represents current (A).

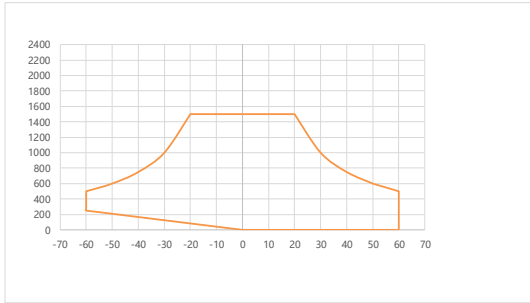

Figure 5 CD30-1K5B Power Curve Diagram

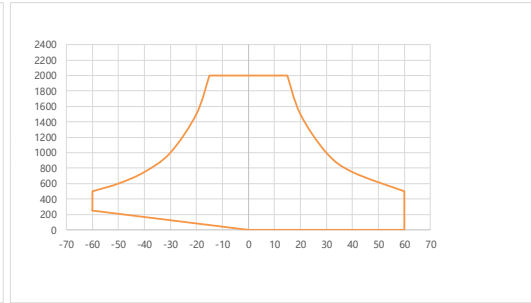

Figure 6 CD30-2K0B Power Curve Diagram

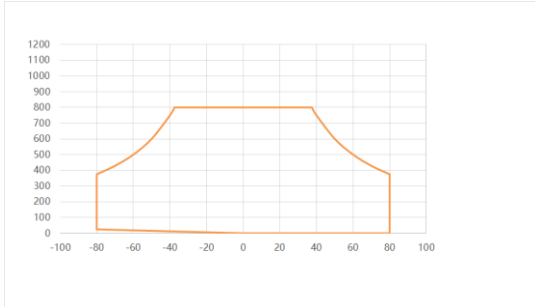

Figure 7 CD30-800B Power Curve Diagram

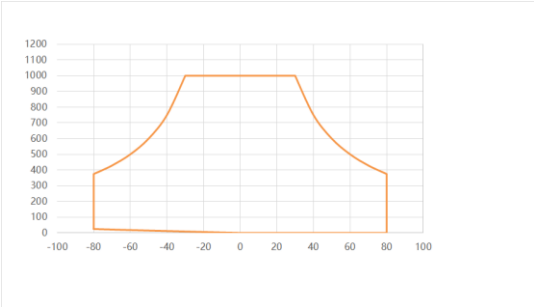

Figure 8 CD30-1K0B Power Curve Diagram

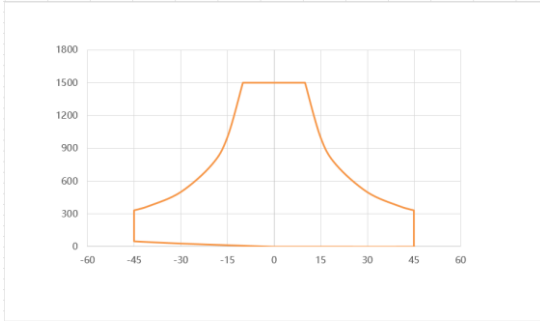

Figure 9 CD15-1K5B Power Curve Diagram

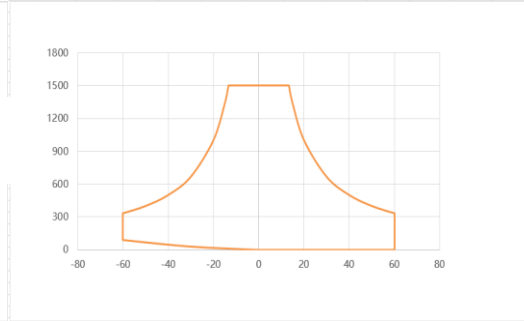

Figure 10 CD20-1K5B Power Curve Diagram

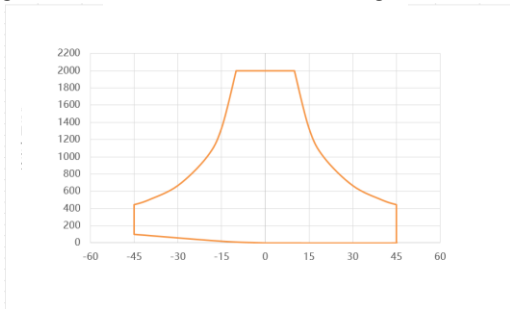

Figure 11 CD15-2K0B Power Curve Diagram

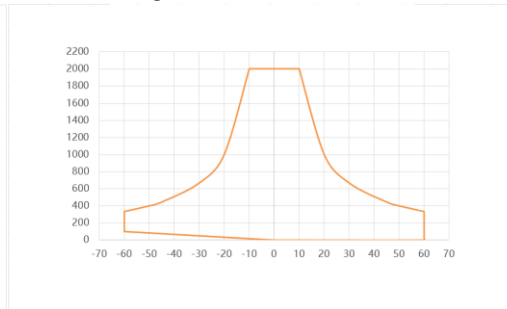

Figure 12 CD20-2K0B Power Curve Diagram

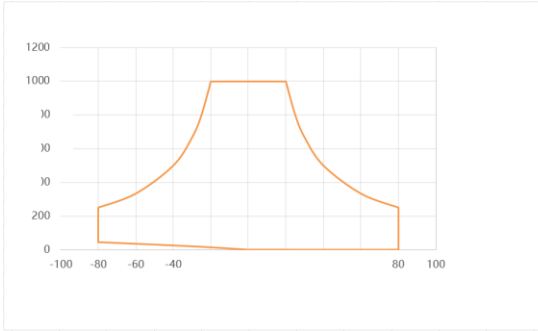

Figure 13 CD20-1K0B Power Curve Diagram

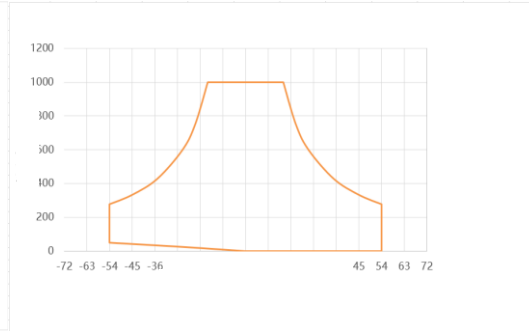

Figure 14 CD15-1K0B Power Curve Diagram

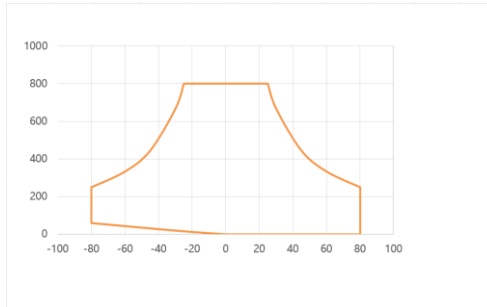

Figure 15 CD20-800B Power Curve Diagram

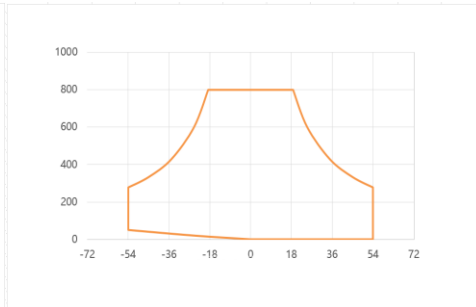

Figure 16 CD15-800B Power Curve Diagram

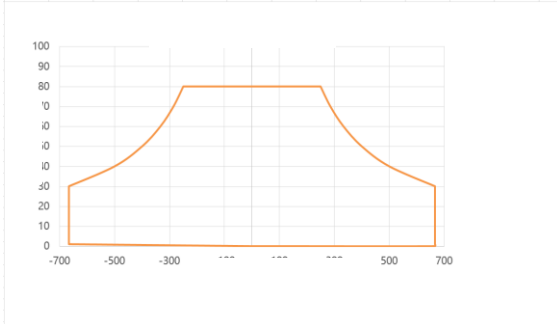

Figure 17 CD20-080B Power Curve Diagram

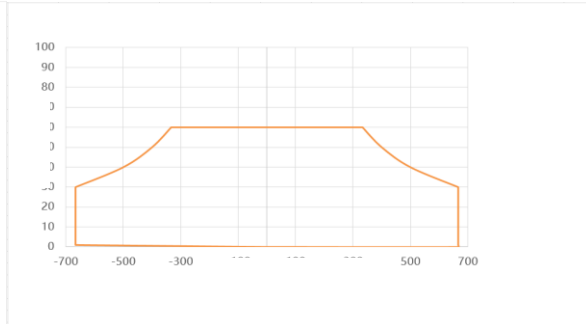

Figure 18 CD20-060B Power Curve Diagram

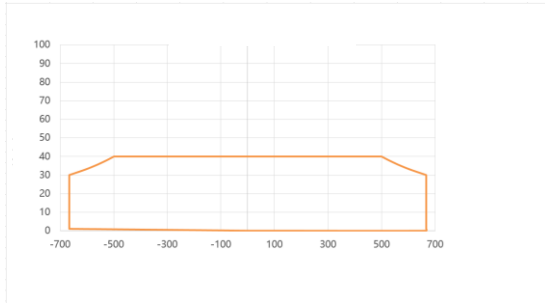

Figure 19 CD20-040B Power Curve Diagram

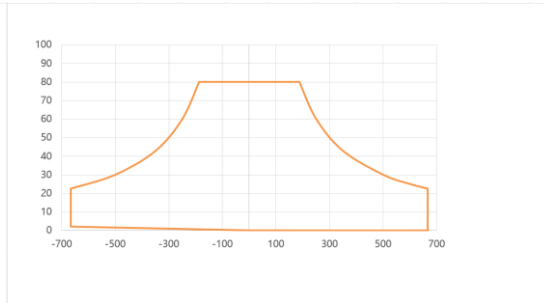

Figure 20 CD15-080B Power Curve Diagram

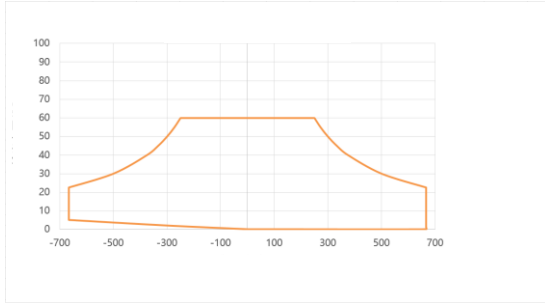

Figure 21 CD15-060B Power Curve Diagram

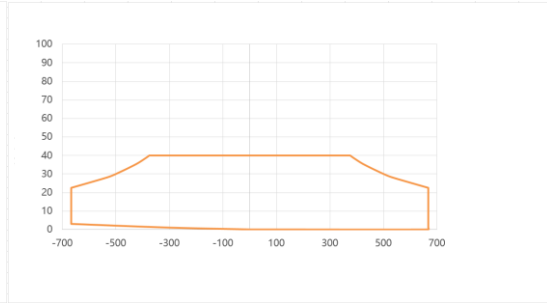

Figure 22 CD15-040B Power Curve Diagram

The figure below shows CD-A different model power curves

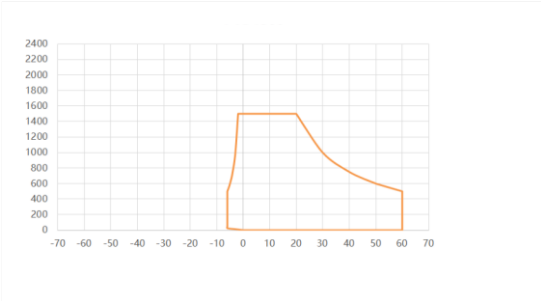

Figure 23 CD30-1K5A Power Curve Diagram

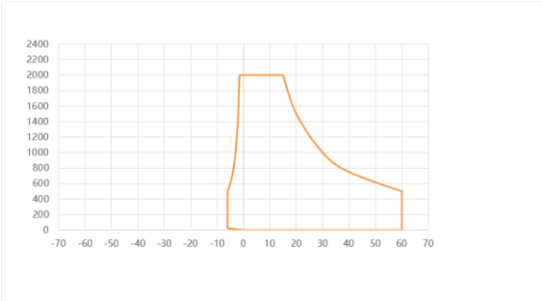

Figure 24 CD30-2K0A Power Curve Diagram

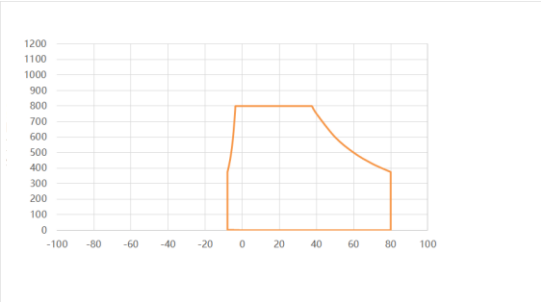

Figure 25 CD30-800A Power Curve Diagram

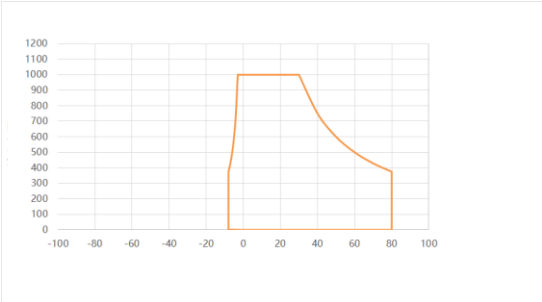

Figure 26 CD30-1K0A Power Curve Diagram

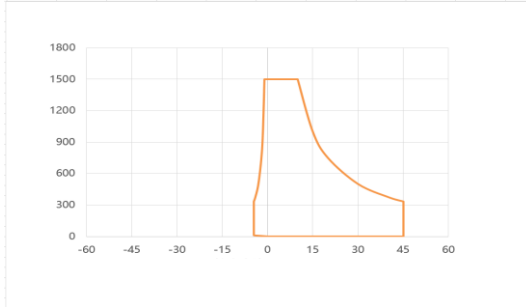

Figure 27 CD15-1K5A Power Curve Diagram

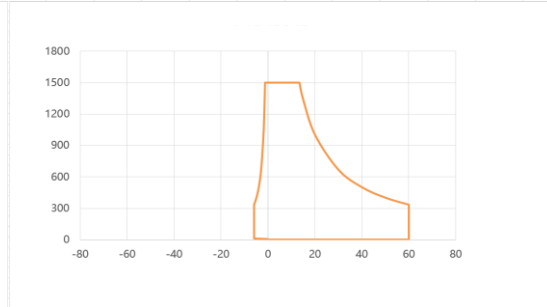

Figure 28 CD20-1K5A Power Curve Diagram

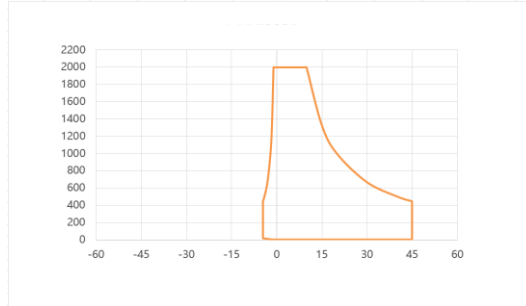

Figure 29 CD15-2K0A Power Curve Diagram

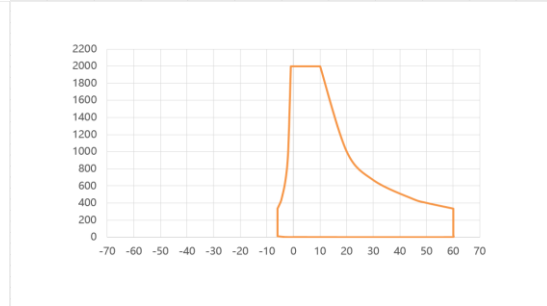

Figure 30 CD20-2K0A Power Curve Diagram

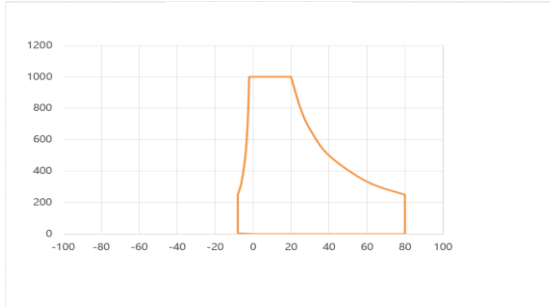

Figure 31 CD20-1K0A Power Curve Diagram

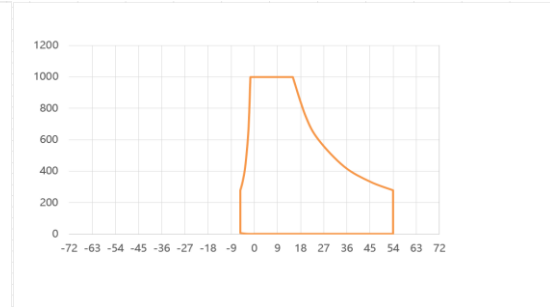

Figure 32 CD15-1K0A Power Curve Diagram

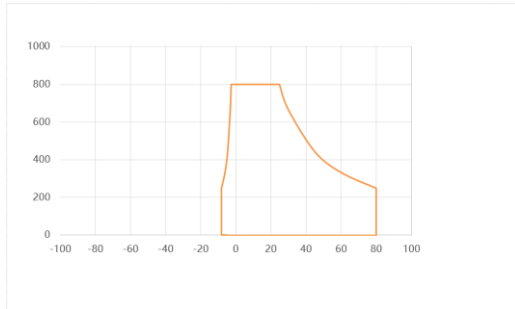

Figure 33 CD20-800A Power Curve Diagram

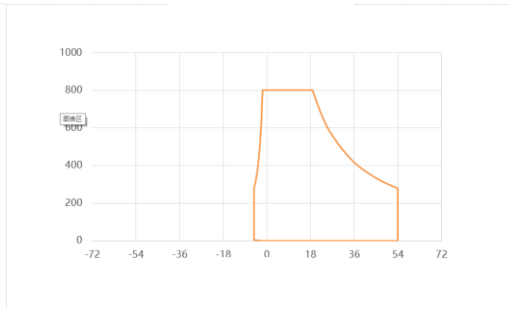

Figure 34 CD15-800A Power Curve Diagram

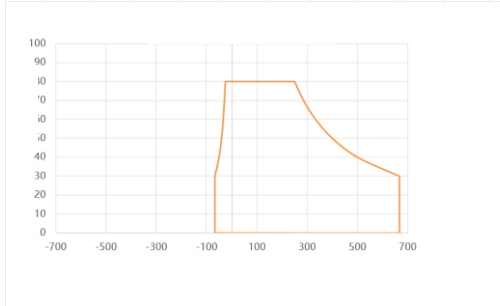

Figure 103 CD20-080A Power Curve Diagram

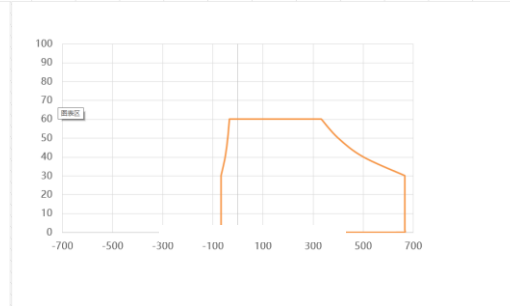

Figure 104 CD20-060A Power Curve Diagram

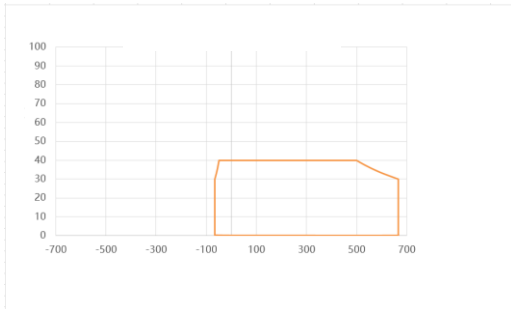

Figure 105 CD20-040A Power Curve Diagram

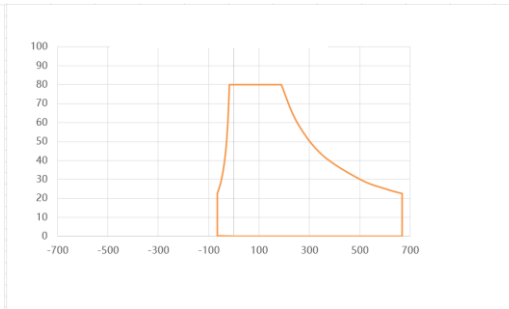

Figure 106 CD15-080A Power Curve Diagram

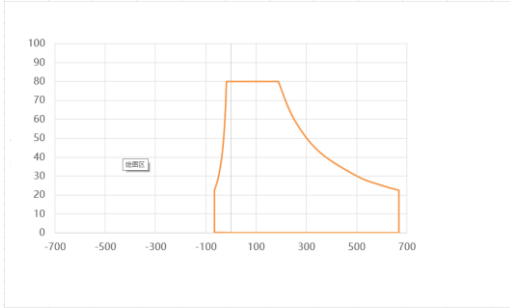

Figure 107 CD15-060A Power Curve Diagram

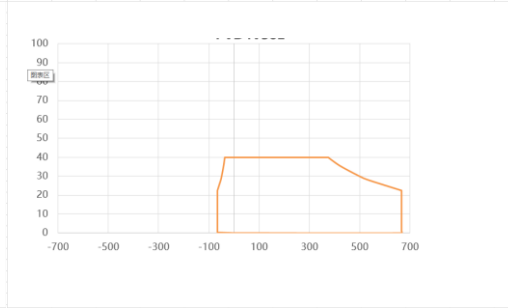

Figure 108 CD15-040A Power Curve Diagram

3.6 Standard Configuration List

This product includes the listed accessories upon delivery as shown in table 2 and table 3. If one or more accessories are incorrect or missing, please contact our after-sales service.

Table 2 Accessory Name and Quantity Table

Model	Accessory Name	Quantity/Unit	
CD20-040B CD20-040A CD20-060B CD20-060A CD20-080B CD20-080A CD15-040B CD15-060B CD15-080B CD15-040A CD15-060A	3 Pin Input Connector	1/piece	
	CD15-1K5B CD20-1K5B CD15-2K0B CD20-2K0B	Analog Programming Adapter Box	1/piece
	CD20-1K0A CD15-1K0A CD20-1K0B CD15-1K5A CD20-1K5A	Input Cable	1/set
	CD20-800A CD15-1K0B CD20-1K5A CD15-2K0A CD15-800A	Installation Kit	1/set
	CD15-800B CD15-800B CD15-080A CD15-080A	Protective Cover	1/piece
	CD20-800B	Parallel Kit	1/set

Table 3 Attachment Name and Quantity Table

Model	Accessory Name	Quantity/Unit
CD30-1K5B CD30-2K0B CD30-1K5A CD30-2K0A CD30-1K0A CD30-1K0B CD30-800B CD30-1K0A CD30-800A	3 Pin Input Connector	1/piece
	Analog Programming Adapter Box	1/piece
	Input Cable	1/set
	Installation Kit	1/set
	Protective Cover	1/piece
	Parallel Kit	1/set

4 Unpacking and Installation

4.1 Handling and Storage

4.1.1 Handling



The rack ears on the product's front panel are not for handling purposes!

Given the product's weight, manual handling should be avoided as much as possible. If it is unavoidable, support the product from the bottom and do not handle it by external parts (such as rack ears, terminals, or knobs).

Do not move the product when it is open or connected to other equipment!

When changing the product's location, it is recommended to use the original factory packaging materials for handling.

This product should always be moved or placed horizontally.

When moving the product, wear appropriate protective clothing, especially safety shoes. Dropping it could result in serious consequences.

During the use of the product, it is recommended to keep the original packaging materials intact for use when moving the product or returning it for repair. Otherwise, these packaging materials should be disposed of according to environmental protection regulations.

4.1.2 Storage

If the product is stored for a long time, it is recommended to use the original or similar packaging materials. The product should be stored in a dry indoor environment, with openings sealed as much as possible to prevent internal components from corroding due to moisture.

4.2 Inspection

Before unpacking, please carefully check the integrity of the packaging. If there are any abnormalities or potential causes of

equipment damage, please contact the after-sales service of Xi'an ActionPower Electric Co., Ltd. immediately.

After unpacking, please carefully check against the standard configuration list to ensure accuracy. If there are any anomalies or potential causes of equipment damage, please contact Xi'an ActionPower Electric Co., Ltd. after-sales service immediately.

When transporting the product with or without packaging, all should be based on the standard configuration list (see Section 3.6) to check whether the product is complete and undamaged. Products with obvious damage (e.g., loose internal components, damaged enclosure) must not be used under any circumstances.

4.3 Environmental Requirements

4.3.1 Ventilation and Derating

This product adopts a front panel air intake and rear panel air exhaust design. To ensure normal operation of the product, at least 30cm of space should be reserved for ventilation at the rear of the product during installation to avoid overheating protection. The maximum output power can be referenced Figure 109 Power-Temperature Curve and Figure 110 Power-Input Voltage Curve.

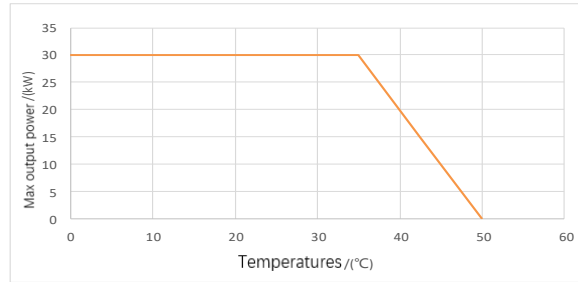

Figure 109 Power-Temperature Curve Diagram

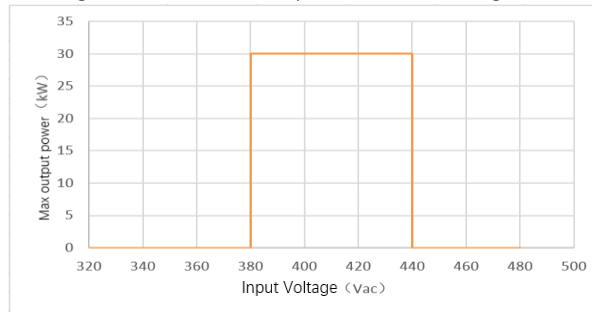

Figure 110 Power- Rated Input Voltage Curve Diagram

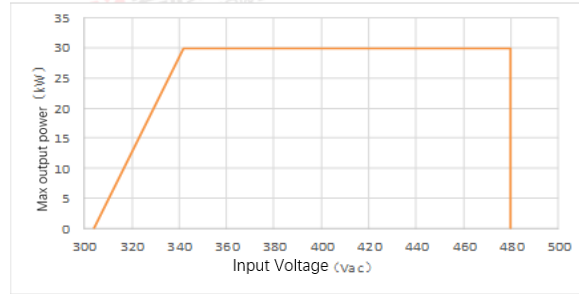

Figure 111 Power-Input Voltage Curve Diagram

4.3.2 Noise

In high-temperature environments, when the device operates at or near its rated full power, the fan speed will reach its maximum. At 1 meter from the front panel of this product, the noise level of this product may exceed 70dB. The operator should implement measures to reduce the noise level at the point of use to a safe level. These measures may include installing noise-reducing baffles or providing protective earplugs.

4.3.3 Liquid Protection

This product does not have a liquid protection function. Do not install it in places where chemicals or liquids may spill.

4.3.4 Cleaning

This product is not designed for user cleaning or equipped with cleaning accessories. It can be used for a long time under the recommended environment. If cleaning is necessary, please contact the manufacturer's after-sales service.

4.4 Installation Specifications



The product is relatively heavy. Therefore, the location where the product is placed (table, cabinet, shelf, rack) must be able to support its weight.

The bottom of this product is equipped with instrument pads, which can prevent sliding and damage to the desktop when used on a table. However, do not forcibly push the product when moving it, to prevent the rubber parts of the instrument pads from falling off, which may even damage the desktop.

When using a cabinet, it is necessary to use rails that match the width and weight of the product's enclosure.

When placing the product in a rack or cabinet, attention must be paid to the depth of the product. The handles on the front panel are only for pushing in or pulling out within the cabinet.

Before connecting to the mains, ensure that the supply voltage matches the voltage indicated on the product's nameplate. AC overvoltage may damage the product.

This series of products features an energy feedback function, similar to solar feedback devices, which can return energy to the local or public power grid. When returning to the public power grid, it is imperative to operate according to the rules of the local power supply company, and before installation, or at least before initial commissioning, it should be investigated whether it is necessary to install a grid protection device.

Choose a location for the product that is as close as possible to the load or external source for connection.

Reserve enough space for ventilation at the back of the product, at least 30cm.

As Figure 112 shown ① position is the only correct placement for the product, no other placement is allowed, and it cannot be used for floor-standing.

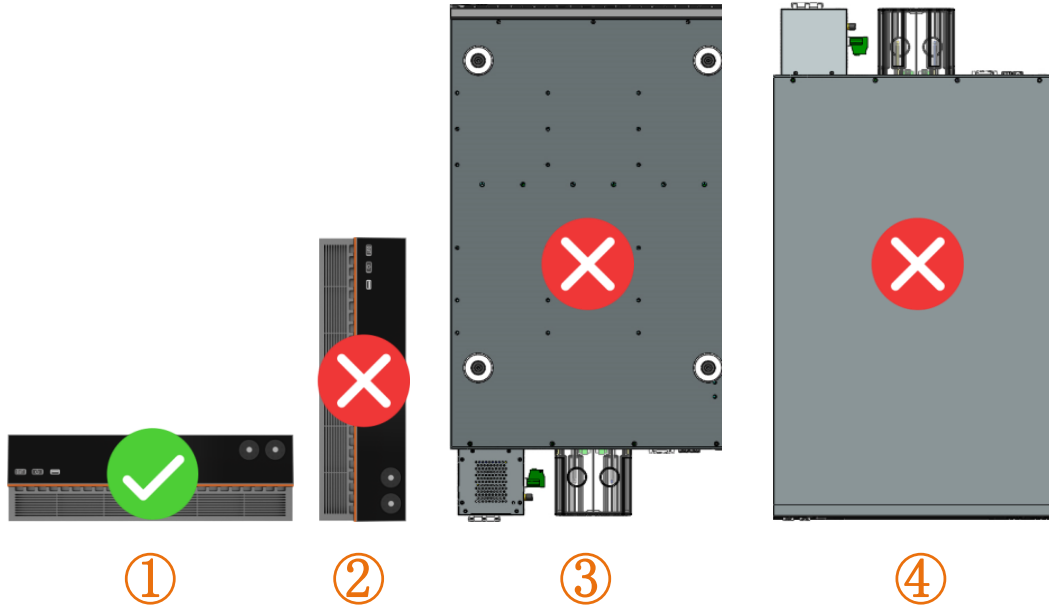

Figure 112 Product Placement Diagram

4.5 Rack Ear Connection

When this product needs to be placed in a standard cabinet, the rack ears can be installed as shown, as Figure 113.

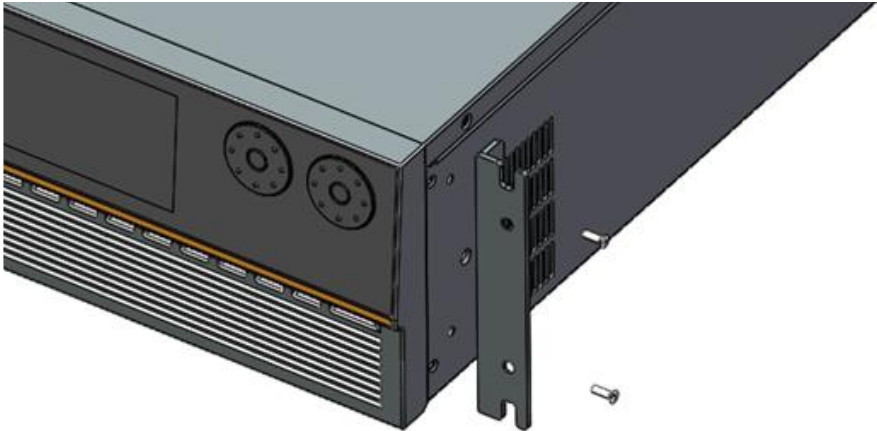

Figure 113 Rack Ear Installation Diagram

4.6 Handle Connection

When this product needs to be pushed or pulled into the cabinet, the handles can be installed as shown, as Figure 114.

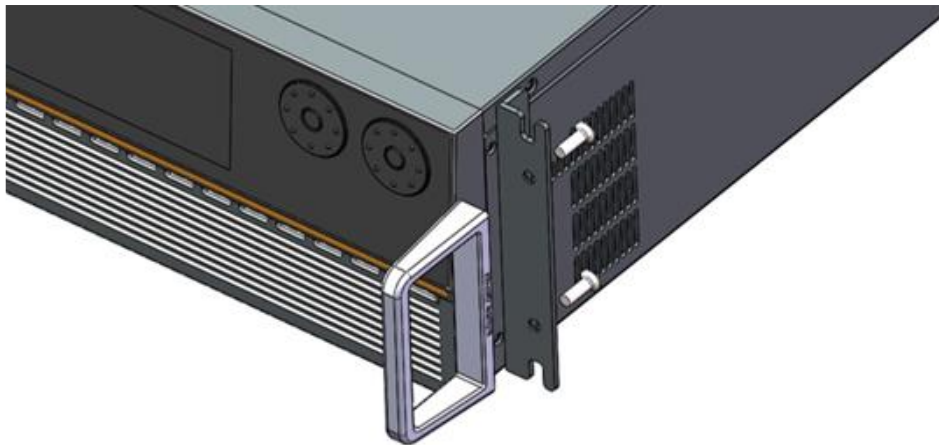

Figure 114 Handle Installation Diagram

4.8 AC Terminal Connection



Only qualified personnel should perform the connection of the AC power supply terminal.
This product must be directly connected to the power grid (a transformer can be connected here), and not to devices like generators or UPS that lack power absorption capability!
The cross-section of the connecting wire must meet the product's maximum output current requirements!
Ensure compliance with all rules for the operation and connection of energy return devices with the public power grid and meet all necessary conditions!
The connecting wires must be secured within the nylon fixing ring!

The product input supports a wide range of voltage and frequency and is adaptive to the phase of the AC input voltage. Before connecting the AC power supply to the product, you must check the label on the equipment or this manual to verify that its AC input configuration matches the local power grid. If the AC input voltage and frequency do not match, please do not connect the AC power supply to this product.

The product's AC input connection must include a disconnecting device (external switch or circuit breaker) as part of the installation. The disconnecting device must be located at an appropriate position on the AC side and must be marked as the disconnecting device for the equipment. The disconnecting device must disconnect all conductors simultaneously.

An external overcurrent protection device (such as a fuse or circuit breaker) must be provided.

The breaking capacity of the overcurrent protection device should match the rated current of the device.

Basic insulation is required between power connection components with opposite polarity on the power supply side of the overcurrent protection device.

Overcurrent protection devices must not be installed in the protective conductor. The neutral line of multiphase equipment should not have fuses or single-pole circuit breakers installed.

Select the appropriate cross-sectional area and length for connecting wire according to the rated AC current of the product. Since the maximum input current of this series of standalone products at full load is 50A, the cross-sectional area of each phase wire should be greater than 6mm².

The three-position input connector for AC power supply can accommodate cables up to 16 mm². Due to the internal resistance in the wire, the longer the connecting wire, the greater the voltage drop. Therefore, the power cord should be as short as possible or use a wire with a larger cross-sectional area.

Longer connecting wires should be secured within the nylon loop placed under the input circuit breaker to prevent the input connecting wires or terminals from being pulled out when the equipment is moved.

The wiring method of the AC terminal is as Figure 116 shown.

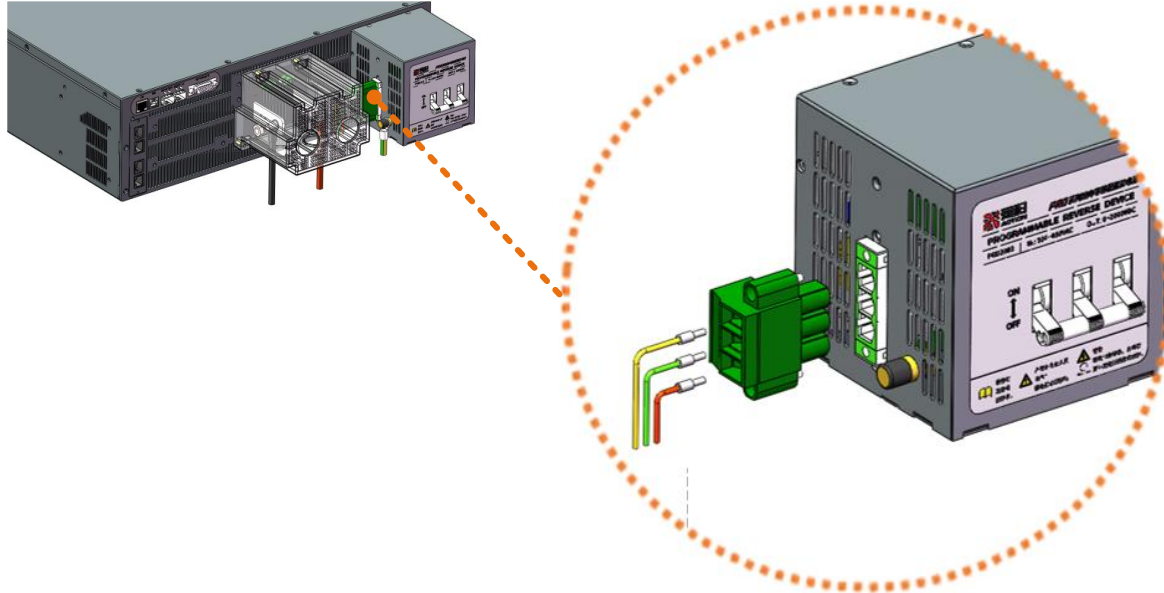
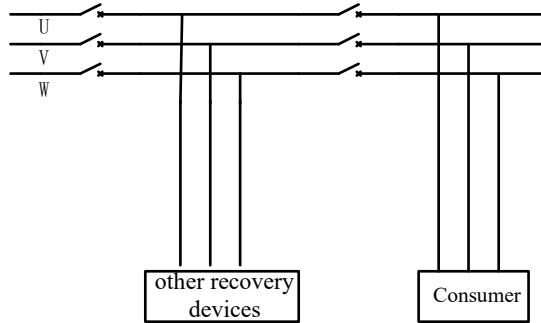

Figure 116 Schematic diagram of AC terminal wiring method

Note: Precautions for feedback-type equipment

Between any two output sockets of the power grid, circuit breakers or fuses are usually not installed Figure 117 illustrating one typical working condition. Once any electrical equipment's AC part fails (e.g., short circuit), not only will the power grid output a

large current to the electrical equipment, but the feedback-type equipment may also output a large current to the electrical equipment, and the current will increase as the power of the feedback-type equipment increases. Even if the circuit breaker at the power grid location trips, the feedback-type product will continue to supply power to the electrical equipment, which may lead to an expansion of equipment faults or cause wires or connection terminals to catch fire. To avoid such issues, a circuit breaker or fuse must be installed between the two output sockets of the power grid. This product has considered such hazardous situations, and a circuit breaker has already been installed inside the product, so users do not need to install an additional circuit breaker.



(a) Other recovery grid connections

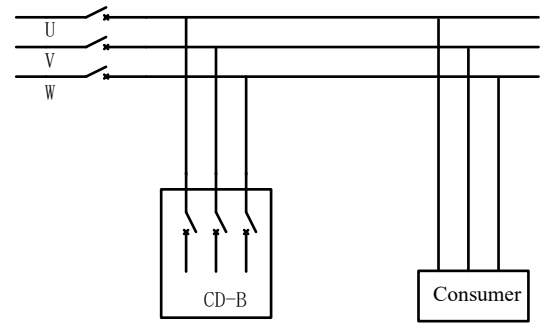

(b) CD-B power grid connections

Figure 117 Schematic diagram of the power grid connection method for feedback-type equipment

4.9 PE terminal connection



The PE wire is very important and must always be reliably connected! The wiring method for the PE terminal is as Figure 118 shown:

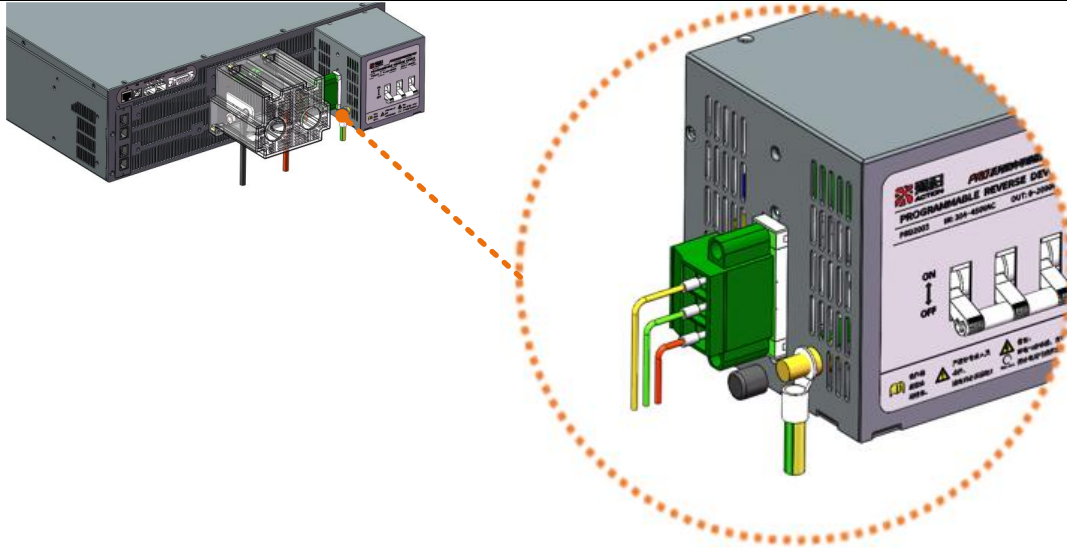

Figure 118 Schematic diagram of PE terminal wiring method

4.10 Output terminal connection



If the product's rated current is relatively large, a thick and heavy direct current connection cable is required, which necessitates considering the weight of the cable and the tension on the output terminal. Especially when the product is installed in a cabinet or similar enclosure, the cable will hang from the output terminal, and a cable gland should be used to secure the cable.

Due to the product's structural reasons, when it is connected to an external source, it will draw a small current even if the direct current input is turned off, approximately 15mA.

This product does not have reverse polarity protection! Connecting it with reverse polarity will damage it, even if it is not powered on!

The output terminal is located in the middle of the rear panel of the product. The cross-section of the wiring here is determined by the current loss, wire length, and ambient temperature. We recommend using cables no longer than 5 m, and the average ambient temperature should not exceed 30°C.

When installing the output terminal, you need to first pass the cable through the protective cover, then secure the cable to the copper bar on the output terminal and finally install the protective cover. Only for the models (CD15-040B, CD15-040A, CD15-060B, CD15-060A, CD15-080B, CD15-080A, CD20-040B, CD20-040A, CD20-060B, CD20-060A, CD20-080B, CD20-080A) the cable can be directly secured to the copper bar. The wiring method of the output terminal is shown as Figure 119 and Figure 120.

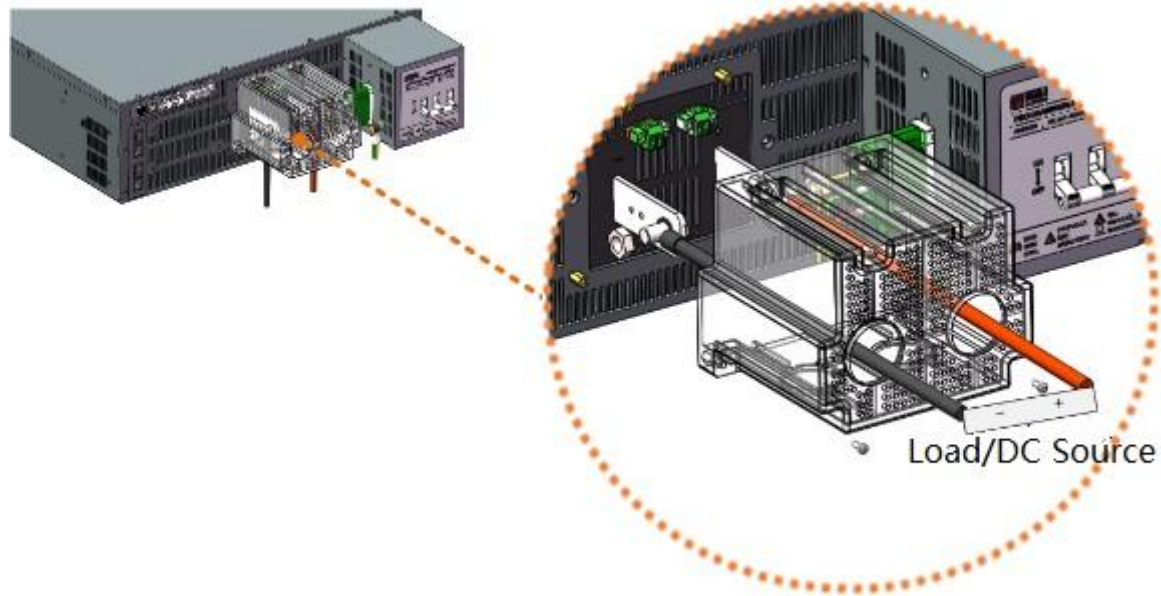

Figure 119 Output Terminal Installation Diagram

4.11 Remote Compensation Connection



The cross-sectional area of the compensation wire is not very important. For cables with a length of 5 m or less, a cross-sectional area of 0.5 mm² is recommended.

The compensation wire should be twisted and placed near the DC wire.

The compensation wire should be connected with the load / power supply as + to +, - to -, otherwise it will damage the compensation terminal.

In parallel mode, the compensation wire is only connected to the main product.

The dielectric strength of the compensation wire must at least meet the rated DC voltage.

When using a power supply with an output voltage greater than 60VDC, there is a potential electric shock hazard at the compensation point. Ensure that the connections at the load end are shielded to prevent contact with hazardous voltages.

When using shielded compensation wires, the shield layer should be grounded at a single point.

To compensate for voltage drops on cables connected to the load or external source, the remote compensation interface can be connected to the load or external source. For models 200V and above, the maximum compensation value is Max.Voltage and 2%F.S. $\pm 1V$. For models below 200V, the maximum compensation value is Max.Voltage $\pm 1V$. The connection method for remote compensation is as follows Figure 121 and Figure 122.

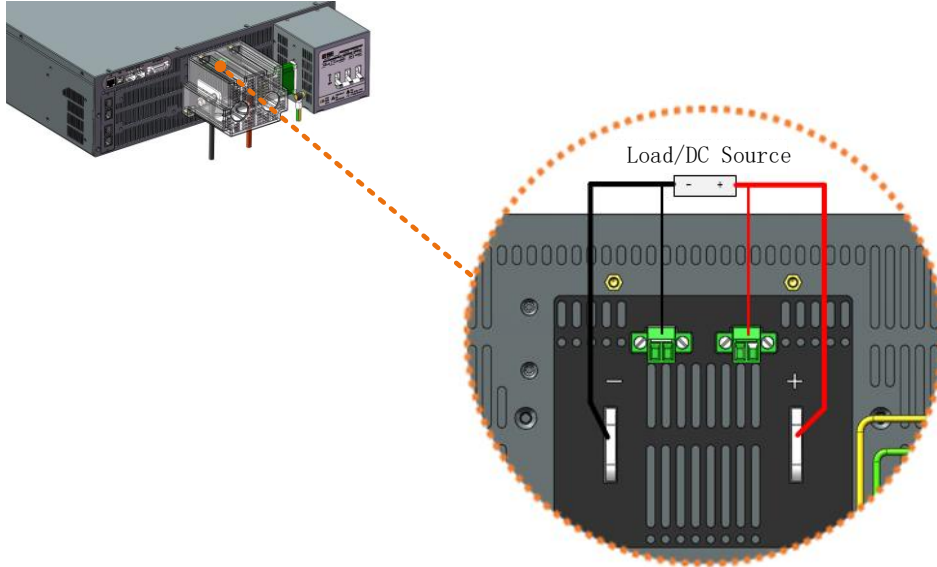

Figure 121 Remote compensation connection diagram

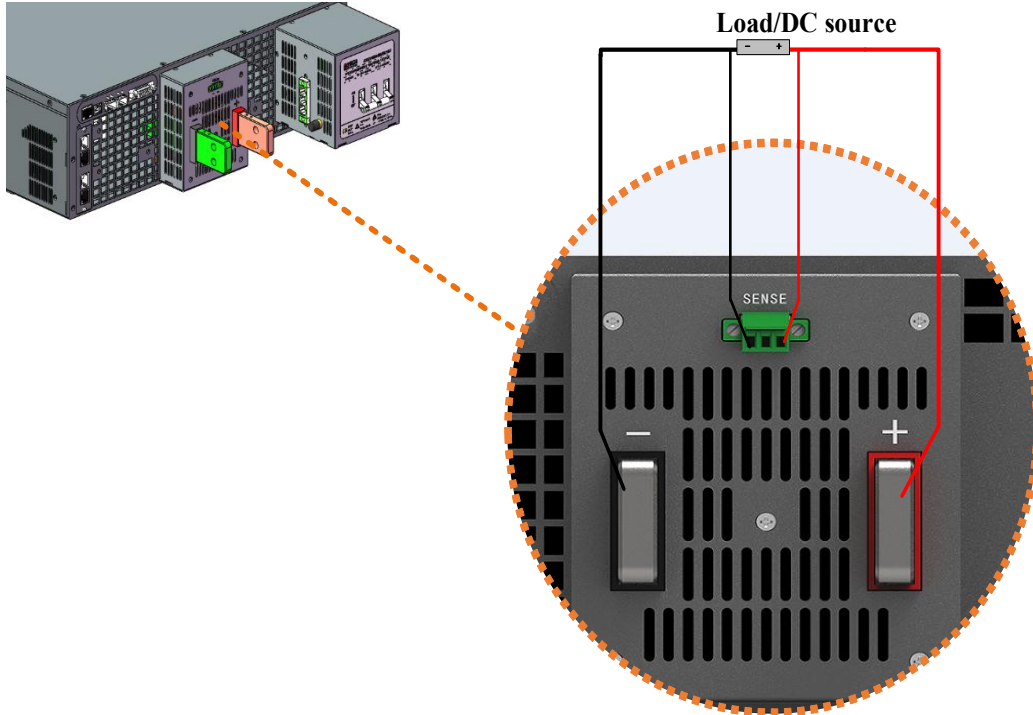

Figure 122 Remote compensation connection diagram

4.12 Magic-Box/ Magic-Bus Installation



When inserting or replacing modules, follow ESD protection procedures.
The product must be turned off before inserting or removing modules.
Do not insert any hardware other than interface modules into this slot.

This product has two external function expansion interfaces, both designed with a bus structure, allowing them to be used interchangeably.

Magic-Box/ Magic-Bus boards come in various models, and users can refer to the Magic-Box/ Magic-Bus board manual for selection and purchase. Magic-Box/ Magic-Bus boards can be assembled and disassembled by the user.

Using a screwdriver, remove the Magic-Box/Magic-Bus board panel and pull out the existing Magic-Box/Magic-Bus board. Then align the required Magic-Box/Magic-Bus board with the slot and insert it, finally use a screwdriver to install the panel.

The installation diagram of the Magic-Box / Magic-Bus board is as shown Figure 123 shown.

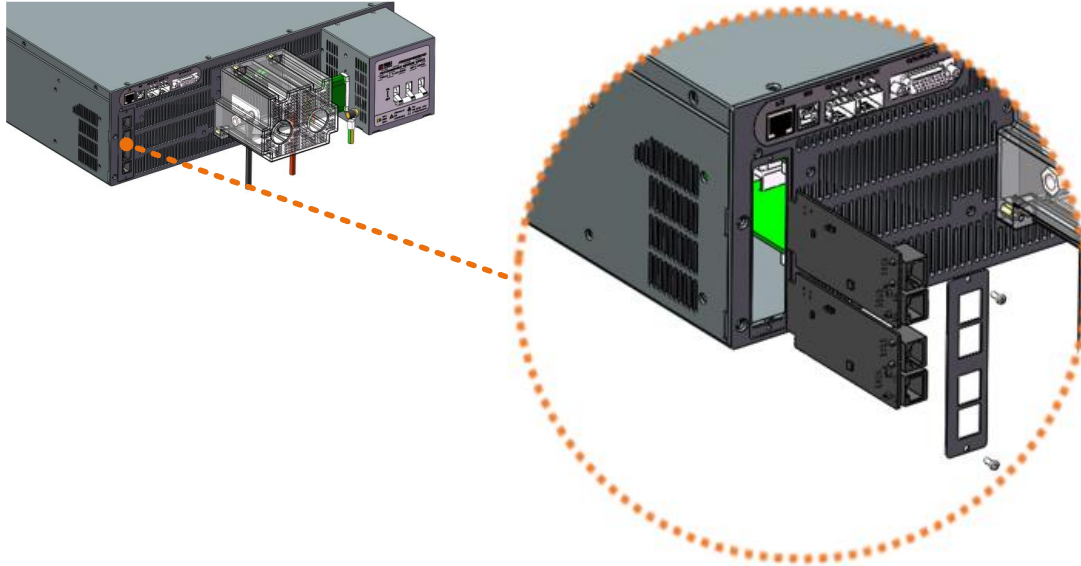

Figure 123 Magic-Box/ Magic-Bus board installation diagram

4.13 Anyport Interface Installation

Anyport is a multi-functional interface, if you need to use this interface, you can connect using a simulation programming converter, before connecting or disconnecting the Anyport interface, you must disconnect the power input.

The installation method of Anyport is as Figure 124 shown.

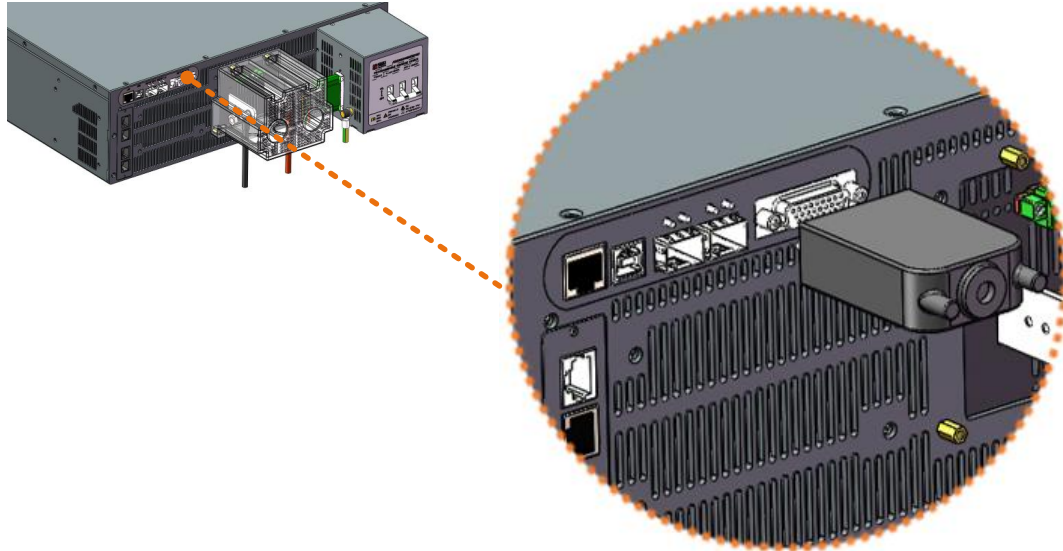

Figure 124 Installation diagram of Anyport.

4.14 Energy Matrix Interface Installation



When inserting the optical module into the Energy Matrix interface of this product, please ensure that the product is powered off before performing the operation!

When this product is paralleled, the output busbars need to be short-circuited according to the positive and negative polarities, and optical fiber lines should be used for communication. Due to the limitation of communication speed in unidirectional parallel connection, in parallel configuration, the units can be parallel separately in row and column directions to maximize capacity. Taking a 3-row 3-column parallel method as an example Figure 125 as shown, the optical fiber should be inserted into the optical module, the optical module should be fastened, and then the optical module should be inserted into the Energy Matrix interface of this product.

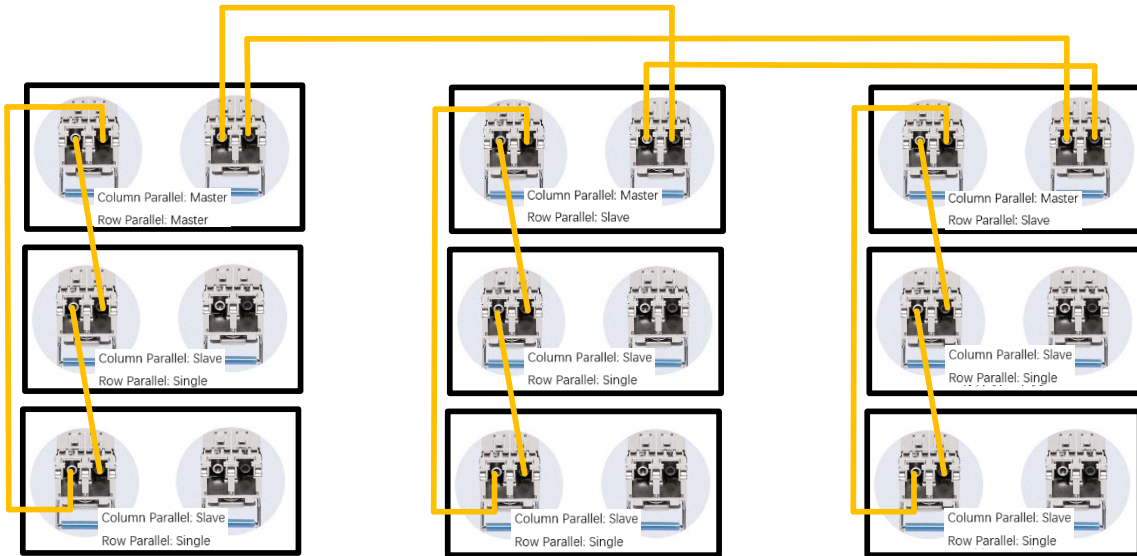

Figure 125 Parallel Optical Fiber Connection Diagram

5 Front Panel

5.1 User Notice

5.1.1 Important Notice



To ensure safety during the use of the product, only personnel familiar with and trained in high-voltage electrical safety operation specifications are allowed to operate this product.
For locations that may generate hazardous voltages, it is essential to use protective devices.
Please read carefully and follow all safety warnings and instructions in the Safety Information!

5.1.2 General Notice



The optimal operating point of this product is between 10% and 100% of the rated voltage and current.

5.2 Front Panel Layout

This product features an integrated panel design, incorporating physical buttons into the panel, achieving a seamless blend with the device when powered off. The operational functions are allocated based on the principles of usage frequency and operational habits, with button functions placed at the lower left and rotary functions at the upper right, greatly accelerating operational efficiency and improving accuracy. The distinction of operational functions also considers both left-handed and right-handed users, allowing every operator to work with ease.

Front panel functional partition as Figure 126, Figure 127 shown, including display screen, external storage interface, power/reset button, output button, left shuttle knob, left shuttle button, right shuttle knob and right shuttle button.



Figure 126 CD-B front panel functional partition figure



Figure 127CD-A Front Panel Function Partition Figure

5.2.1 Display Screen

This product uses an 8.8-inch, 1920* 480 resolution, 16-bit RGB ultra-wide aspect ratio LCD touch display screen, capable of displaying more information. Users can operate and control the product through the touch display screen and physical buttons.

5.2.2 External Storage Interface

The external storage interface is used for connecting USB storage devices, allowing information exchange between the product's internal and USB storage devices.

5.2.3 Power/Reset Button

The Power/Reset button is the CD-B button for turning on, off, or resetting, with a three-color indicator function.

5.2.4 Output Button

The output button is used to turn on or off the output terminal function and features a three-color indicator function.

5.2.5 Left/Right Knob and Button

The backlight of the left/right jog button is off by default. When the jog button is pressed, the backlight turns on, and the corresponding jog dial is enabled. The button has an anti-mis operation function. If there is no operation for 5 seconds, the backlight of the jog button automatically turns off, and the function of the corresponding jog dial is disabled.

The left/right jog dial is used to set the values on the right side of the main interface of the display screen, such as output voltage, frequency, current, etc. Turning clockwise increases the value, turning counterclockwise decreases the value. The left/right shuttle button is used to move the cursor to the corresponding digit position. Users can use the shuttle knob instead of the on-screen numeric keypad to set the desired value.

5.3 Power/Reset Button Related Operations

5.3.1 Power On/Off

CD-B Before powering on, check the following items:

Step 1: First open the rear door panel of the cabinet and check that the power module is supplied normally, whether the AC circuit breaker on the rear panel is switched to the right to the ON position, see Figure 128 status 2.

Step 2: Switch the AC circuit breaker on the rear panel of the control module to the right to the ON position, see Figure 129 State 2.

Step 3: Connect to the power grid, ensure the front panel power/reset button indicator light turns yellow, indicate the standby state, see Figure 130 State 2.

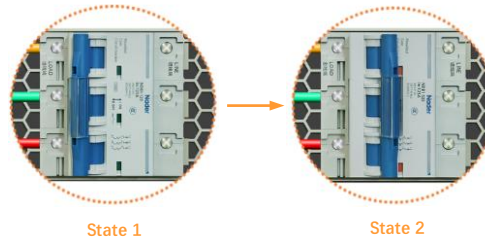

Figure 128 Power Module Power-On Diagram

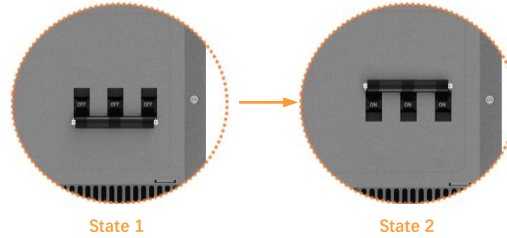

Figure 129 Control Module Power-On Diagram

CD-B Power-On Operation:

Press and hold the power/reset button until the indicator turns green, indicating the standby state, see Figure 130 State 2, which completes the product power-on.

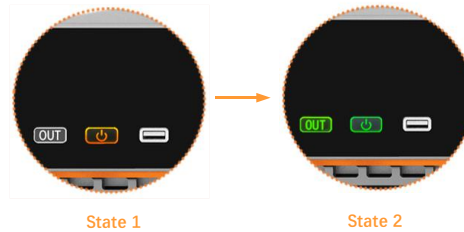

Figure 130 Power-On Process Diagram

CD-B Power-Off Operation is as follows:

Step 1: Disconnect the output terminal, see Figure 131 State 1.

Step 2: Press and hold the power/reset button until the indicator light changes from green to yellow, see Figure 131 State 2.

Step 3: Switch the rear panel AC circuit breaker down to the OFF position, see Figure 129 State 1 indicates the product shutdown is complete.

In emergency situations, when energy is fed back to the power grid through the product, it is still possible to shut down by directly disconnecting the AC terminal circuit breaker. However, under normal circumstances, it is recommended to follow the above shutdown procedure for standard operation.

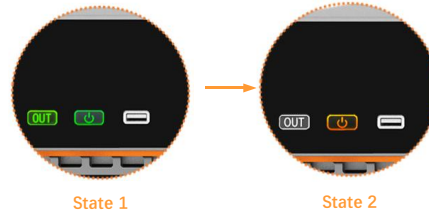

Figure 131 Shutdown Process Diagram

5.3.2 Automatic Startup

CD-B features an automatic startup function, simplifying the startup process and making it convenient for users.

For automatic startup, the product's startup mode must be set to automatic, see section 7.12.

5.3.3 Reset

The reset operation for CD-B is as follows:

Step1: The power/reset button indicator light turns red, and the State display area shows a protection State, see Figure 132 State

1.

Step2: Briefly press the power/reset button, and the output button indicator light starts flashing. The reset action is completed when both the power/reset button indicator and the output button indicator turn green, and the State display area changes from protection State to standby State, see Figure 132 State 2.

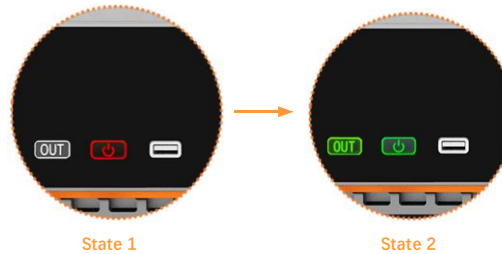

Figure 132 Reset Process Diagram

5.4 Output Button Related Operations

The output button is used to connect or disconnect the output terminal. When the button indicator is off, it means the output terminal cannot be operated. When the button indicator shows green, it means the output terminal is disconnected. When the indicator shows red, it means the output terminal is connected.

5.4.1 Manual Output

The output operation of CD-B is as follows:

Step 1: The power supply is in standby state, see Figure 133 State 1.

Step 2: Press the output button, the output relay engages, the output button indicator changes from green to red, see Figure 133

State 2: At this time, the product output terminal is connected.

Step 3: Press the output button again, the output relay disconnects, and the output button indicator light changes from red to green, see Figure 133

State 3: At this time, the product output terminal is disconnected, and the power supply is in standby mode again.

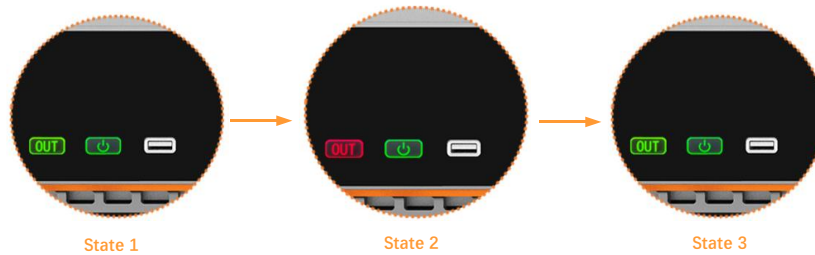

Figure 133 Output Connection State Diagram

5.4.2 Automatic Output

CD-B features an automatic output function. When the product operation mode is set to automatic, see Section 7.12, the product will automatically output according to the last saved parameter settings after startup.

5.4.3 Output Connection/Disconnection Delay

CD-B features output connection delay and disconnection delay functions.

When setting the product connection delay time, see Section 7.6, in standby mode, after pressing the output button, the output button indicator light changes from green to yellow, see Figure 134 State 2, after waiting for the set turn-on delay time, the output relay engages, and the output button indicator changes from yellow to red, see Figure 134 State 3, at this time the product's output terminal is connected.



Figure 134 Output Turn-On Delay State Diagram

When setting the product's turn-off delay time, see Section 7.6, in the output state, after pressing the output button, the output button indicator changes from red to yellow, see Figure 135 State 2, after waiting for the set turn-off delay time, the output relay disengages, and the output button indicator changes from yellow to green, see Figure 135 State 3, at this time the product's output terminal is disconnected.

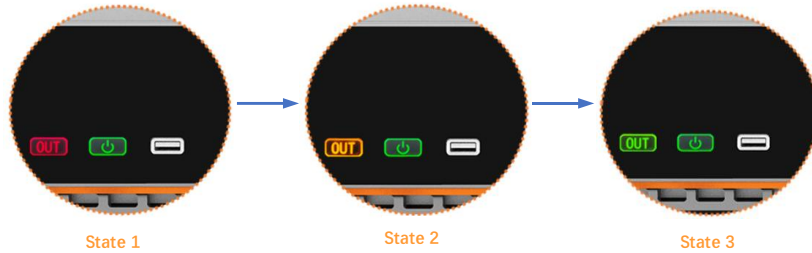

Figure 135 Output Turn-Off Delay State Diagram

5.4.4 Operating Sequence

5.4.4.1 Output Turn-On Sequence

To extend the lifespan of the internal relay, see the output turn-on sequence Figure 136.

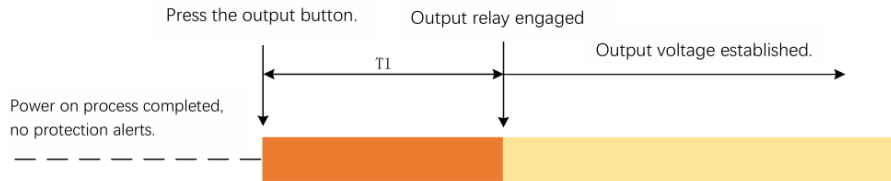

Figure 136 Output Connection Timing Diagram

Figure 136 In the diagram, T1 is the time from pressing the output button to the output relay engaging. This time is influenced by various factors such as connection delay parameters and response delay, with a minimum of 100ms.

5.4.4.2 Output Disconnection Timing

See Output Disconnection Timing in Figure 137.

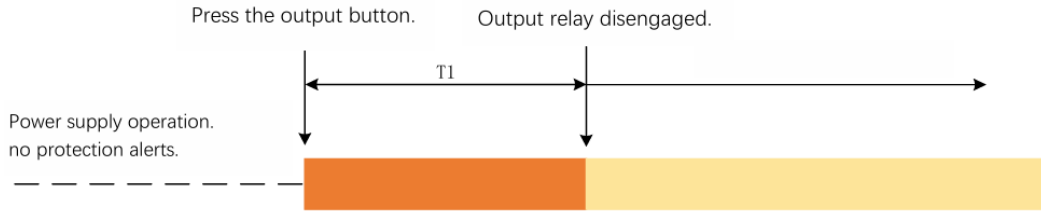

Figure 137 Output Disconnection Timing Diagram

Figure 137 In the diagram, T1 is the time from pressing the output button to the output relay disengaging. This time is influenced by factors such as shutdown slew rate, shutdown angle, and disconnection delay parameters. The output voltage is reduced to zero before the output relay disengages.

6 Rear Panel

The rear panel includes Anyport interface, Energy matrix interface, LAN interface, USB interface, optional interface, SENSE interface, output copper bar positive electrode, output copper bar negative electrode, three-phase input connector, PE terminal, and AC terminal circuit breaker. For models with output of 200V and above, the rear panel is as follows Figure 138, The rear panel of models with output below 200V is as Figure 139 shown.

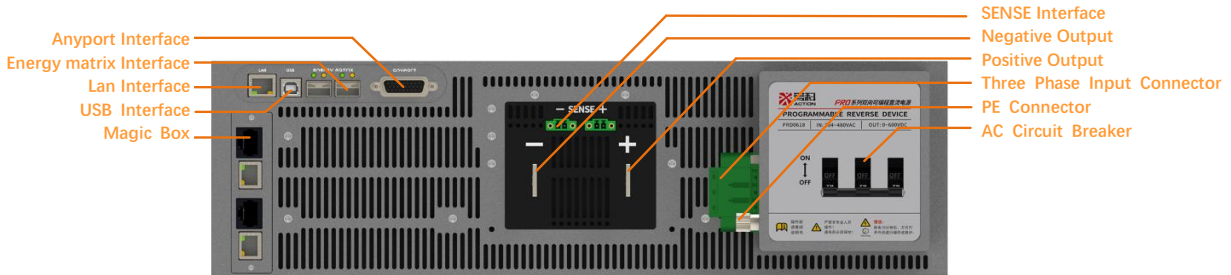

Figure 138 Rear Panel Functional Partition Diagram

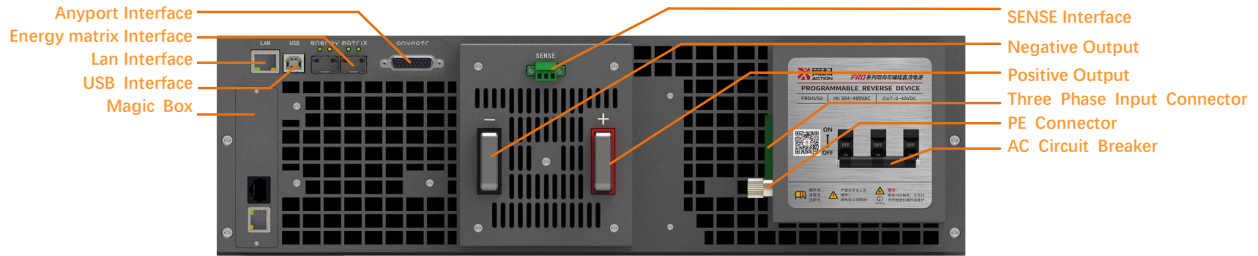
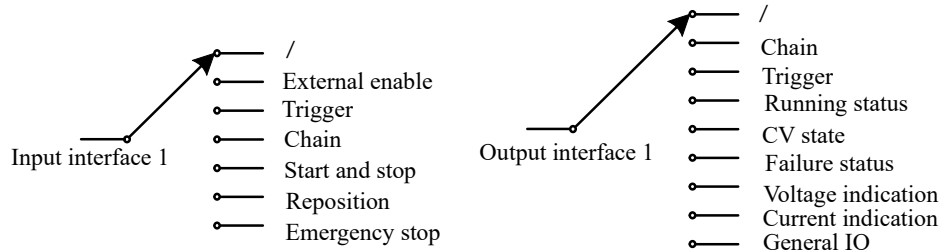

Figure 139 Rear Panel Functional Partition Diagram (Output Voltage Below 200V)

6.1 Anyport Interface

Anyport is a multifunction interface, with three types: input, output, and analog. Users can configure this interface to achieve operation and monitoring of the product's running status.

The 6-channel input interface and 6-channel output interface can be configured separately to meet different control needs. The functions of the input and output interfaces are as Figure 140 shown.



shown in Figure 140 Anyport Digital Input and Digital Output Interface Functional Diagram

The analog interface functions are fixed, but the input range can be configured. Once enabled, it can achieve voltage, current, power, internal resistance, and analog control. For detailed functional information, see below Table 4.

Table 4 Anyport Interface Function Table

Interface Type	Pin Position	Signal Level	Function Description
Digital Input	Pin10	0V~10V	6 pins correspond to 6 input interfaces, each of which can be configured for external enable, trigger, interlock, start-stop, reset, and emergency stop functions. The interface defaults to TTL high level. For interface configuration and function introduction, see 7.3.1.1.
	Pin11		
	Pin19		
	Pin20		
	Pin21		
	Pin22		
Digital Output	Pin1	0V~10V	6 pins correspond to 6 output interfaces, each pin can be configured to achieve interlock, trigger, voltage indication, current indication, general I/O functions, and can also monitor
	Pin2		

Interface Type	Pin Position	Signal Level	Function Description
	Pin3		the product's operating status, CV status, and protection status. The interface defaults to OC (Open Collector), and when in use, it needs to be externally pulled up to a high level. It is recommended to pull up to a voltage of 5V or not exceeding 10V, with a pull-up resistor of 1kΩ, refer to Figure 141For detailed information on interface configuration and functions, see Section 7.3.1.2.
	Pin4		
	Pin14		
	Pin15		
Analog	Pin6	-10V~10V/ -5V~5V	This pin is for external resistance settings. The internal resistance value of this product is set by providing a given voltage signal. The given voltage value is proportional to the internal resistance of this product. Its maximum range corresponds to the maximum settable internal resistance of this product. The range can be configured in the " Configuration-Anyport interface", for details see Section 7.3.2.
	Pin7	-10V~10V/ -5V~5V	This pin is for external power setting. The power limit of the product is set by providing a given voltage signal. The given voltage value is proportional to the output power, and its maximum range corresponds to the rated power of the product's output. The range can be configured in the "Configuration-Anyport interface", for details see Section 7.3.2.
	Pin8	-10V~10V/ -5V~5V	This pin is for external current setting. The current limit of this product is set by providing a given voltage signal. The given voltage value is proportional to the output current, with its maximum range corresponding to the rated current at the product's output. The range can be configured in the "Configuration-Anyport interface", for details see Section 7.3.2.
	Pin9	0V~10V/ 0V~5V	This pin is for external voltage reference, used to set the voltage limit of the product through a given voltage signal. The given voltage value is proportional to the output voltage, with its maximum range corresponding to the rated voltage at the product's output. The range can be configured in the " Configuration-Anyport interface", for details see Section 7.3.2.
	Pin24	10V	This pin is a 10V voltage reference output. Users can appropriately divide the voltage at this pin and connect it to the external voltage/current/power/internal resistance reference pin to set the product's settings.

Interface Type	Pin Position	Signal Level	Function Description
	Pin25	0V~5V	The voltage at this pin represents the voltage at the product's output, and this voltage value is proportional to the output voltage.
	Pin26	-5V~5V	The voltage at this pin represents the current at the output terminal of this product, and this voltage value is proportional to the output terminal current.
Ground terminal	Pin5	/	These 7 pins are the negative terminals of the input, output, and analog interface pins, common ground.
	Pin12		
	Pin13		
	Pin16		
	Pin17		
	Pin 18		
	Pin 23		

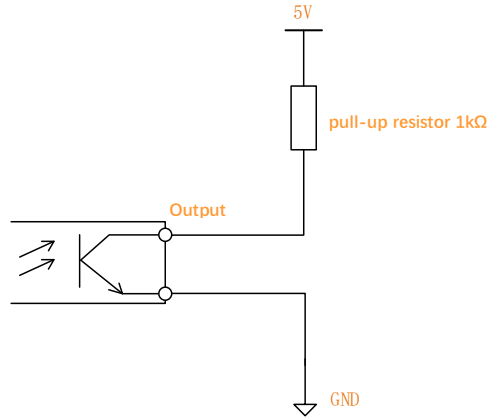

Figure 141 Schematic diagram of Anyport output interface with external high level

6.2 LAN interface

The LAN interface is used for remote control. Standard RJ45 interface, default port number is 502. Supports SCPI or Modbus-TCP two protocol command sets, see details in section 3.4.

Note: Only one of the LAN and USB interfaces can be used.

6.3 USB interface

The USB interface is used for remote control, the interface is Type -B interface, supports USB2.0 type, transmission rate can reach 480Mbps, to ensure communication reliability, the cable length is not allowed to exceed 2m, also supports SCPI or

Modbus-RTU two protocol command sets, see details in Section 7.11.

Note: Only one of the USB or LAN interfaces can be used.

6.4 Optional Interface

The optional interface can expand the functions of this product, for use in different industries. Users can refer to the Magic-Box/Magic-Bus manual to purchase the required expansion components. The optional interface has two card slots, both of which can automatically recognize Magic-Box/Magic-Bus functional components, but only one Magic-Box and Magic-Bus can be installed. It cannot recognize two different functional Magic-Box or Magic-Bus.

6.5 SENSE Interface

This product features a high-precision 6.5-digit sampling system and is designed with an independent control sampling and display system. Even if an anomaly occurs in the control system, this product can still provide protection.

The SENSE interface has a remote compensation voltage function, which can directly compensate for the voltage drop on the line from the output terminal to the external load/direct current source. The value displayed in the output display area is calculated from the SENSE interface sampling, so it must always connect the remote compensation line to the output terminal or load terminal.

6.6 Output Busbar Positive/ Negative Electrode

The output busbar is the output terminal of this product, which can be connected to an external load or direct current source. Before use, ensure positive to positive and negative to negative. Even if not powered on, incorrect wiring can cause irreversible

damage to this product. The output terminal may carry dangerous voltage after activation, and it must be handled according to Section 4.10, and install protective cover.

6.7 Three-pin input connector

The three-pin input connector is the AC terminal of this product, which can be directly connected to the power grid. Before connecting, make sure to switch the upstream circuit breaker to the OFF position.

6.8 PE connector

The PE connector is the grounding terminal of this product. To ensure personal and equipment safety, the PE connector must always be connected to ground.

6.9 AC terminal circuit breaker

The AC terminal circuit breaker is an important switch connecting this product to the grid side, featuring overload and short circuit protection functions. Switching the AC terminal circuit breaker to ON powers the device, while switching it to OFF cuts the power. When not using this product, make sure to switch the circuit breaker to the OFF position.

7 Display Screen Functions and Operations

All parameter settings and functional applications of the CD-B can be achieved through the operation of the front panel display screen. The display screen's functional interface is divided into 14 parts , see the function tree diagram Figure 142, in each functional interface, you can swipe left or right, or up and down to view related content.

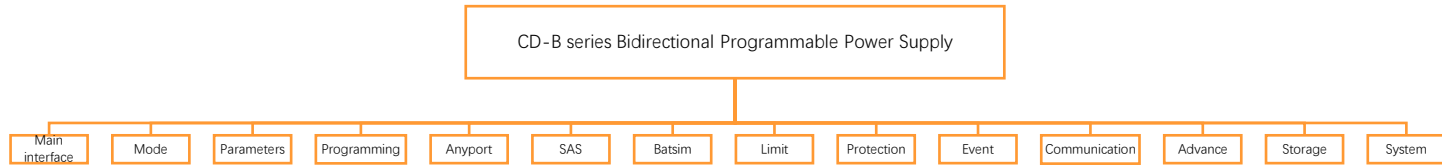

Figure 142 Function Tree Diagram

7.1 Main Interface

The main interface is as Figure 143 shown, divided into 7 areas: Status Display Area, Menu Key, Home Key, Output Display Area, Dropdown Shortcut Area, Function Editing Area, and unction Editing Area. Different areas can achieve different functions, allowing users to quickly obtain the information needed in these interfaces.

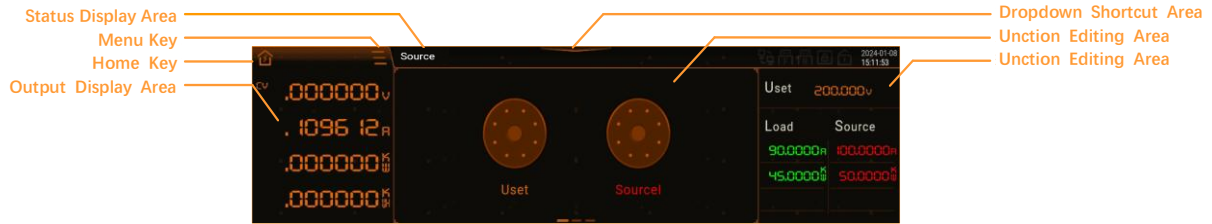



Figure 143 Main Interface Diagram

7.1.1 Dropdown Shortcut Area

The dropdown shortcut area provides some basic common operations, which can enhance user operation efficiency. The same functions can still be operated in the corresponding menu items, and the respective functions do not currently support adjustment or modification.

The user can click the button at the top center of the screen “” to open the dropdown shortcut area. Clicking other areas can close the dropdown shortcut area. The functional interface of the dropdown shortcut area is shown in Figure 144 and Table 5.

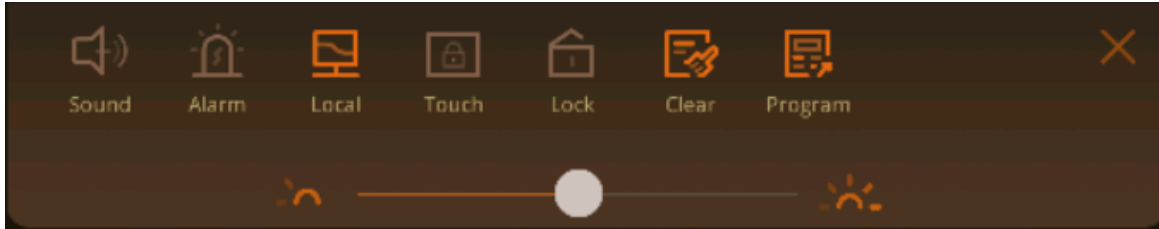

Figure 144 Dropdown Shortcut Area Diagram

Table 5 Shortcut Area Functions Table

Button	Explanation and Operation
Alarm Sound	When protection/ alert/event signal sound prompts are needed, this button will light up, and the device screen will display the status while an alarm sound will be heard as a prompt.
Local/ USB/LAN/ BUS	Click this button to cycle through the four states of Local/ USB/LAN/ BUS
Screen Lock	To prevent accidental operations or when you need to lock the screen, press this button to activate, but the same operation can deactivate this function.
Local Lock	To prevent remote commands from modifying control rights, press this button to activate, and the device can only allocate control rights through the display screen.
Clear Event	Clear occurred events and statuses.
List	Quickly jump to the List programming interface.

7.1.2 Status Display Area

The status display area at the top of the screen indicates the working status and working mode of this product, such as Figure 145, for detailed information see Table 6.

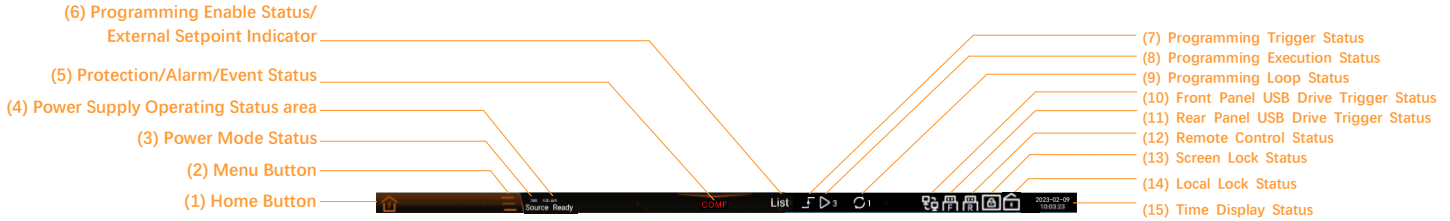









Figure 145 Status Display Area Diagram

Table 6 Status Display Area Function Table

Status Area	Display Content	Explanation and Application
(1) Home Button		Click the Home button to return to the main interface.
(2) Menu Button		Click the menu button to display the menu bar on the right side of the interface.
(3) Power Mode Status	Source	When the product voltage is greater than the user device voltage, it operates in Source mode, with the output voltage being positive and the current being positive.
	Load	When the product voltage is greater than the user device voltage, it operates in Load mode, with the output voltage being positive and the current being negative.
	SAS	Solar Array Simulation Enable solar panel simulation function.
	BatSim	Battery Simulator activates the battery simulation function.
(4) Power Supply Operating Status	Standby	The output terminal of this product is disconnected. When the output terminal is not in use, the product can be set to standby mode. For operation methods, see Section5.4.1.
	Operation	The output terminal of this product is connected. When the output terminal is needed, the product can be set to operation mode. For operation methods, see Section5.4.1.
	Protection	The product enters protection mode, at which point the output terminal is turned off and a reset operation is required to return to standby mode. When the user needs to protect the product and

Status Area	Display Content	Explanation and Application
		user equipment to operate within a safe range, protection parameters can be set for protection, see Section 7.9.
	Reset	Product reset can restore it to standby mode. When protection/alarm/event occurs, if the user needs to return to standby mode, they can press the power/reset button or use Anyport external input reset signal to perform the reset operation, see Section 7.3.1.1.
	Emergency Stop	This product disconnects output in an emergency stop. When the user needs to disconnect the output urgently, they can press the output button or use the Anyport external input emergency stop signal to perform the emergency stop operation, see Section 7.3.1.1.
(5) Protection Status	CHAF	Interlock Protection. Receives external interlock signals through 'Anyport', see Section 7.3.
	SLAF	Power Module Protection. Indicates protection of any power module.
	INSF	Internal Protection. Indicates internal module protection.
	POWF	Power Supply Protection. Indicates abnormal external power supply.
	OPP	Overpower protection. It indicates that the output power is higher than the 7.5.6section's set value.
	OCP	Overcurrent protection. It indicates that the output current is higher than the 7.5.6section's set value.
	OVP	Overvoltage protection. Indicates that the output voltage is higher than the 7.5.6section's set value.
	OTP	Exhaust port over-temperature protection.
	LVP	Load undervoltage protection. In load mode, the output port voltage is lower than the 7.9section's set value.
	PARF	Communication protection. Indicates an abnormal optical fiber connection.
	COMF	Communication timeout protection. Indicates an abnormal internal network cable connection in the product.
	SENF	Telemetry protection. Indicates an abnormal feedback cable.
	WDP	Communication monitoring protection.
OSOC	BatSim charging SOC protection. It indicates that the battery charging SOC is greater than the section 7.5.6 set value.	

Status Area	Display Content	Explanation and Application
	LSOC	BatSim discharge SOC protection. It indicates that the battery discharge SOC is less than the section 7.5.6 set value.
	OVOL	BatSim charging protection. It indicates that the battery charging voltage is greater than the section 7.5.6 set value.
	LVOL	BatSim discharging voltage protection. It indicates that the battery discharging voltage is less than the section 7.5.6 set value.
	FUSE	BatSim fuse current protection. It indicates that the battery fuse current is greater than the section 7.5.6 set value.
(5) Alarm Status	WAIT	WAIT alarm. Indicates that the fiber optic connection is not ready.
	SASL	SAS over-limit alarm.
	IP	IP conflict alarm.
	BATL	BatSim over-limit alarm.
	CYCL	Cycle cutoff alarm.
	OSOC	BatSim charging SOC alarm.
	LSOC	BatSim discharging SOC alarm.
	OVOL	BatSim charging voltage alarm.
	LVOL	BatSim Discharge Voltage Alarm.
PARA	Parallel Alarm.	
(5) Event Status	Event X	Displays triggered user events, e.g., Event 1.
(6) Programming Enable Status/External Setpoint Indicator	Arbitrary Wave	After loading the Arbitrary Wave mode in the Waveform interface, this status is displayed.
	Step	After loading the Step mode in the Programming interface, this status is displayed.
	List	After loading the List mode in the Programming interface, this status is displayed.
	Wave	After loading the Wave mode in the Programming interface, this status is displayed.
	Advanced	After loading the Advanced mode in the Programming interface, this status is displayed.

Status Area	Display Content	Explanation and Application
	Curve Scan	After the curve scanning mode in the photovoltaic interface is loaded, this status is displayed.
(7) Programming Trigger Status		When the programming mode is triggered, this icon will light up.
(8) Programming Execution Status		Displays the sequence number currently being executed by the programming.
(9) Programming Loop Status		Displays the number of loops currently being executed by the programming.
(10) Front Panel USB Drive Trigger Status		When the product detects a front panel USB storage device, this icon will light up.
(11) Rear Panel USB Drive Trigger Status		When the product detects a rear panel USB storage device, this icon will light up.
(12) Remote Control Status		When the remote control is enabled, this icon will light up.
(13) Screen Lock Status		When the screen lock is enabled, this icon will light up.
(14) Local Lock Status		When the local lock is enabled, this icon will light up.
(15) Time Display Status	2024-09-02 14:29:14	Displays the current time (year-month-day-hour- minute- second).

7.1.3 Output Display Area

The output display area is the display area for the device's output parameters, divided into four lines. The first three lines are fixed to display the output voltage, output current, and output power. The fourth line can be edited to display one of the three: charge, energy, or internal resistance. For the setting method, see Section 7.12.

This area data can display a maximum of 6.5 digits, with adjustable display resolution and display rate functions. For applications with lower precision requirements or smaller data range displays, the display can be reduced to 5.5 or 4.5 digits to achieve better display effects.

This product adopts a fully automatic mode design, freeing users from the need to first set the device's constant voltage, constant current, and other working states. In automatic mode, users only need to set the working voltage and maximum current parameters of the device under test. The electrical parameters of the device under test will be limited between these two values, regardless of whether it is operating in source mode or load mode. When operating in automatic mode, the left side of the output display area will indicate the device's different modes.

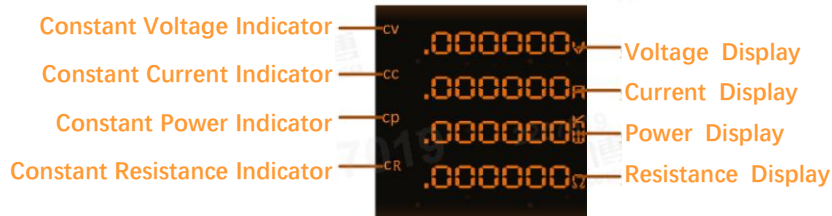

Figure 146 Output Display Area Figure

This product has four mode indicators: Constant Voltage (CV), Constant Current (CC), Constant Power (CP), and Constant Resistance (CR). Among them, the CC, CV, and CP modes can automatically switch according to the formula $P=UI$. That is, when any parameter of voltage, current, or power at the output terminal first reaches the lower limit value, the product will operate in

that mode. The CR mode requires enabling the internal resistance mode, see details Section 7.12.

1. Constant Voltage Indicator (CV)

The output terminal voltage of this product is constant and equal to the voltage set value. Under source mode conditions, the relationship between load impedance and load current satisfies Ohm's Law $R=U/I$, and the load current is less than the current set value. Under the load mode condition, if the voltage of the device under test is higher than the set value of this product, the current is determined by the product or the device under test.

When the current/ power reaches the limit value, the voltage at the output terminal will automatically be lower than the set voltage limit value, and the output voltage is only determined by the formula $U=P/I$, the product automatically switches to constant current/constant power mode. The voltage is no longer constant, being lower than the set value in source mode and higher than the set value in load mode.

2. Constant Current Indicator (CC)

The output current flowing from the product's output terminal to the load (source mode) or absorbed from the load (load mode) is constant and equal to the current set value. In source mode, the voltage and power currently are determined by Ohm's Law $U=IR$. In load mode, the voltage and power currently are determined by the voltage and power of the external DC source.

When the output current is below the set current limit, and the voltage/power reaches the current/power limit value, the product will automatically switch to constant voltage/constant power mode according to the formula $I= P / U$. If the voltage reaches the maximum set value first, the product will automatically switch to constant voltage mode. If the power reaches the maximum set value first, the product will automatically switch to constant power mode.

3. Constant Power Indicator (CP)

The power at the output terminal of this product is constant. In source mode, the voltage and current at this time are determined by the actual resistance value of the connected load according to the formulas $P = UI$ and $P = U^2/R$. In load mode, the voltage and current currently are determined by the voltage and current of the external DC source. At lower voltages, the current flowing through is larger, and at higher voltages, the current flowing through is smaller, thereby keeping the power stable within the power curve range.

When the output power is lower than the set power limit, and the voltage/current reaches the voltage/current limit value, according to the formula $P = U * I$, this product will automatically switch to constant voltage/constant current mode. If the voltage reaches the maximum set value first, the product will automatically switch to constant voltage mode. If the current reaches the maximum set value first, the product will automatically switch to constant current mode.

If the actual current value/voltage value/power value is close to the set current value/voltage value/power value, at this time the product may jump and switch between CC/ CV/ CP modes. In this situation, the accuracy of the product's output parameters may exceed the specifications. It is recommended to appropriately increase other parameters when a specific parameter is set, so that the product operates in a controlled mode.

Example: Assume this product is set to a voltage of 500V, the source mode is set to a current of 10A, and the source mode power is set to 10kW. The load is approximately 50Ω, at this time due to the actual current fluctuating around 10A, when it equals 10A, this product will operate in CC mode, and when it is less than 10A, this product will operate in CV mode, causing this product to switch between CC/ CV modes.

4. Constant Resistance Indicator (CR)

The internal resistance of this product is constant, in source mode, the principle of constant resistance mode is to simulate a

virtual internal resistance in series with the voltage source, which can be connected in series with the load. According to Ohm's Law, due to the presence of internal resistance, it will cause a voltage drop at the output terminal, resulting in a deviation between the voltage set value and the actual output terminal voltage. See the schematic diagram for details. Figure 147.

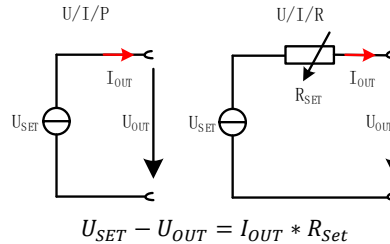

Figure 147 Source Mode Constant Resistance Mode Circuit Schematic Diagram

In load mode, according to the formula $I_{IN} = (U_{IN} - U_{SET}) / R_{SET}$, (I_{IN} is the output terminal current, U_{IN} is the voltage applied to the output terminal, U_{SET} is the set voltage of this product, R_{SET} is the set internal resistance of this product), the actual current is determined by the difference between the external supply voltage and the product voltage set value, as follows Figure 148.

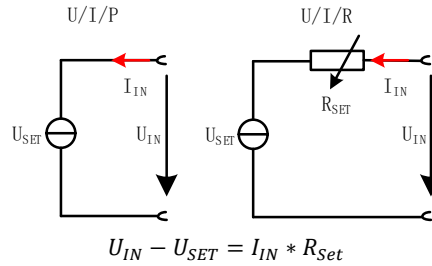

Figure 148 Load Mode Constant Resistance Mode Diagram

Example: If the voltage of the external direct current source is 200 V, and this product's internal resistance R SET is set to 10 Ω, voltage U SET is set to 0 V. Start input at the output terminal, the current will rise to 20 A, and the actual resistance R MON should be close to 10 Ω. When the voltage U SET is adjusted to 100 V, the actual resistance R MON remains at 10 Ω, and the current will decrease to 10 A.

Note: When the voltage at the output terminal of the external direct current source equals the set voltage, this product will not absorb any current and will switch to CV mode. If the supplied input voltage is almost equal to or fluctuates around the set voltage, the operating mode will continuously switch between CV and CR modes. Therefore, it is recommended not to adjust the set voltage to the same level as the external DC source voltage.

The operating mode status can be referenced Table 7.

Table 7 Operating Status Table

CD-B compared with user equipment parameter settings				CD-B Operating Status	
Voltage	Current	Power	Internal Resistance	Source/Load Mode	Indication
H	H	MAX	OFF	Source Mode	CV
H	L	MAX	OFF	Source Mode	CC
H	MAX	H	OFF	Source Mode	CV
H	MAX	L	OFF	Source Mode	CP
L	H	MAX	OFF	Load Mode	CV
L	L	MAX	OFF	Load Mode	CC
L	MAX	H	OFF	Load Mode	CV
L	MAX	L	OFF	Load Mode	CP

Note:

H: This product is set higher compared to the user equipment settings.

L: This product is set lower compared to the user equipment settings.

MAX: When the product parameters are set to the maximum value, they will not be limited during operation.

ON: Internal resistance mode enabled.

OFF: Internal resistance mode disabled.

7.1.4 Function Editing Area

The function editing area is the display area for the shuttle function interface, power curve interface, and waveform reproduction interface, divided into three pages. You can manually slide this area to switch to the corresponding interface.

7.1.4.1 Shuttle Function Interface

The default startup interface is the shuttle function interface, such as Figure 149 shown.

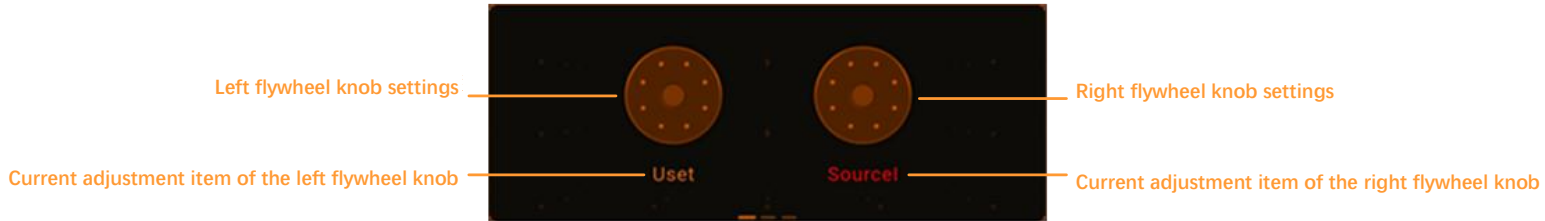

Figure 149 Shuttle Function Interface

The left/right shuttle knob function can be used to configure one of the seven parameters: voltage, source current, load current, source power, load power, source internal resistance, load internal resistance. See the left/right shuttle knob function tree diagram in Figure 150, click the left/right shuttle knob that needs to be configured, press the button to confirm the function, and then Figure 151 select the function parameter to be configured on the right side of the interface as shown. After confirming the function, the device will maintain the currently configured adjustment parameter until it is changed next time.

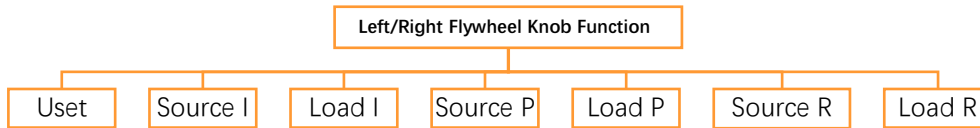

Figure 150 Left/Right Shuttle Knob Function Tree Diagram



Figure 151 Shuttle Parameter Selection Interface

7.1.4.2 Power Curve Interface

This product is designed with a constant power characteristic, meaning it can output the rated power even at lower voltage/current outputs. To clearly represent this state and intuitively indicate the relationship between voltage, current, and power parameters with the rated parameters after setting limit values, the display screen is designed with a power curve boundary indication function.

Swipe right to switch to the power curve interface, as Figure 152 shown. In this interface, the white line represents the rated power curve of CD-B, and the orange line represents the power curve of the current output setting of CD-B. The horizontal axis of the curve is current, and the vertical axis is voltage. The left half current is negative, and the right half current is positive, while the voltage is positive.

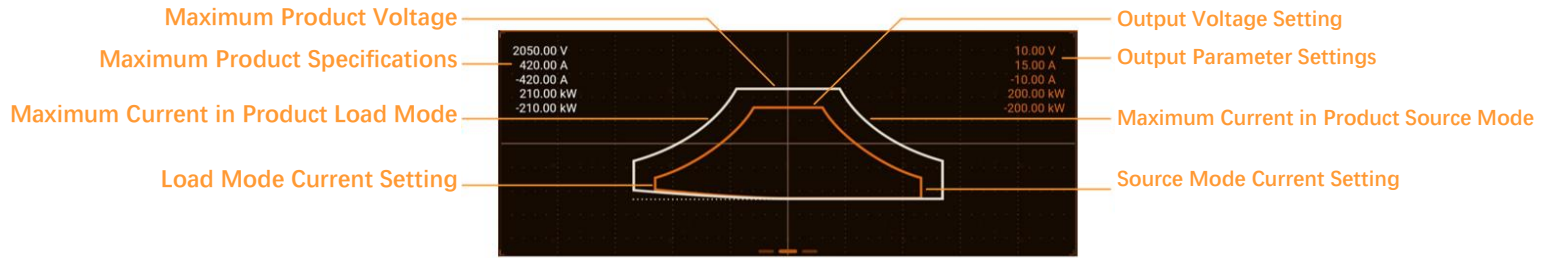

Figure 152 Power Curve Interface Diagram

7.1.4.3 Waveform Reproduction Interface

This product is designed with a waveform reproduction function, which can visually indicate changes in voltage, current, and power during programming and adjusting output parameters, and display them on the screen. The voltage, current, and power coordinates have adaptive functions.

Swipe right to switch the function editing area to the waveform reproduction interface, as shown Figure 153. The accuracy of the waveform reproduction function is affected by the sampling rate and storage depth, which may cause variations. Higher frequency waveforms may experience distortion. The waveform is for user reference only. For more demanding requirements, it is recommended to use a professional oscilloscope.

The waveform rate can be adjusted between 100ms/DIV and 10s/DIV. Click the waveform rate area to switch.

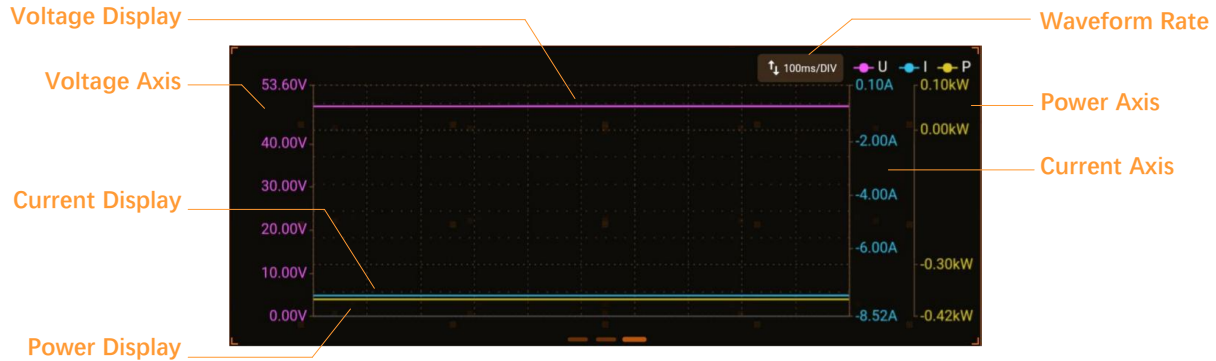

Figure 153 Waveform Reproduction Interface Diagram

7.1.5 Home/Menu Key



Press the menu key  on the main interface, and the menu interface will appear on the right side of the main interface, as shown Figure 154 in the illustration. You can scroll up and down in the menu interface to view all the menu items. On any interface press the Home button  to return to the main interface.



Figure 154 Menu Interface Diagram

Select any menu item from the menu bar , using 'Mode' as an example, click 'Mode' to enter the 'Mode' settings interface as shown Figure 155, click the menu button, the menu bar on the right side of the screen closes, displaying the output settings area, while the 'Mode' settings interface on the left side of the screen remains unchanged, as shown Figure 156, at this point, you can simultaneously set the relevant parameters for 'Mode' and 'Output'.

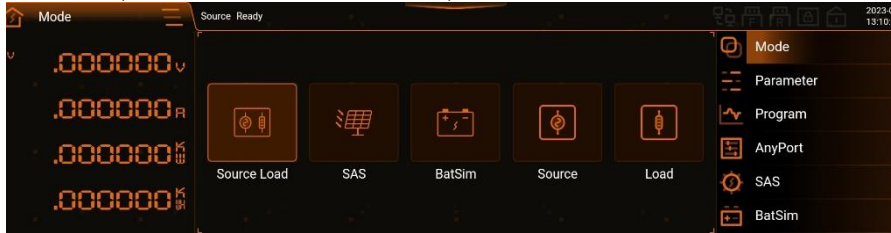

Figure 155 Mode Settings Interface Diagram

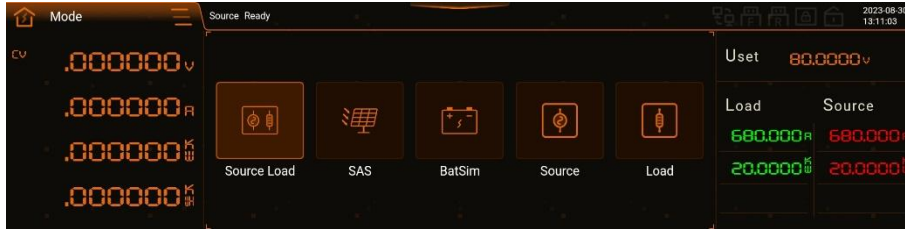

Figure 156 Mode Settings Interface and Output Settings Area Diagram

7.1.6 Output Settings Area

In the Output Settings Area, you can set the output voltage, current, power, and internal resistance in source mode or load mode. The Output Settings Area interface is shown as Figure 157, where internal resistance needs to be enabled in resistance mode to be displayed, see Section 7.12. Click the value and enter the desired parameters on the numeric keypad on the right, see Figure 158, you can also use the left/right dial to set.



Figure 157 Output Setting Area First Figure

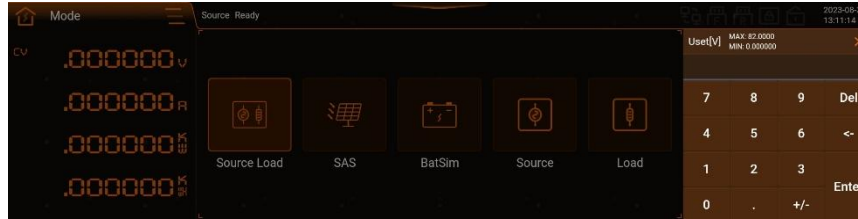

Figure 158 Output Setting Area Second Figure

This product integrates power supply and load function into one unit, allowing seamless switching between the two modes (CD-A can only operate in source mode).

Power Supply Mode: This product operates in power supply mode, providing energy to externally direct current loads. When the voltage at the output terminal of this product is greater than the voltage of the external direct current source, it operates in power supply mode.

Load Mode: This product operates in load mode and can obtain energy from an external direct current source. When the output voltage of this product is less than the voltage of the external DC source, it operates in load mode.

7.2 Programming

CD-B has designed five programming modes, with some functions supporting programming of up to 200 sequences. Through flexible configuration parameters, the desired waveform can be edited. See the programming function tree diagram Figure 159, all programming modes must be used when the product is already outputting.

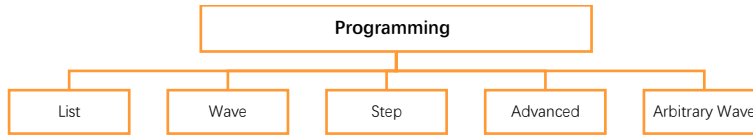

Figure 159 Programming Function Tree Diagram

7.2.1 List

The List includes two parts: editing and configuration. See the List programming function tree diagram Figure 160.

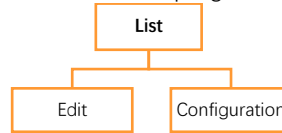



Figure 160 List Function Tree Diagram

Click on Programming-List-Edit in the menu bar to enter the List programming interface, where you can set the List programming parameters yourself, see Figure 161. See the explanation of each parameter Table 8.



Figure 161 List Programming Interface Diagram

Table 8 List Programming Interface Parameter Explanation Table

Parameter Item	Unit	Explanation	Model	Resolution	Setting Range
No.	/	Sequence Number.	ALL	/	1~200
Amplitude [V]	V	The voltage amplitude of this sequence.	ALL	0.001	0~Maximum Voltage
Amplitude [A]	A	The current amplitude of this sequence.	ALL	0.001	-Maximum Current ~Maximum Current
Amplitude [kW]	kW	The power amplitude of this sequence.	ALL	0.001	-Maximum Power ~Maximum Power
Amplitude [Ω]	Ω	The resistance amplitude of the sequence.	ALL	0.001	- Maximum Resistance ~Maximum Resistance
Time[s]	s	The hold time of the current sequence.	ALL	0.0001	0~9999999
Clear 	/	Clear all current programming data and return to Figure 161 the initial programming state.	ALL	/	/
“+”	/	Insert a new sequence after the current sequence, with parameter values identical to the current sequence.	ALL	/	/
“-”	/	Delete the current sequence.	ALL	/	/
Import	/	Import the file containing stored data into the programming interface.	ALL	/	/
Export	/	Export the current programming data as a file and store it.	ALL	/	/
Load	/	Lock the programming data and enter the trigger-ready state.	ALL	/	/
Exit	/	At any time during programming mode, you can click 'Exit' to end the current programming mode.	ALL	/	/
Trigger	/	Switch from a stable output state to a programmed waveform output state.	ALL	/	/

Note: The expected output waveform is still influenced by the limit value parameters. Inappropriate limit settings may cause distortion of the expected output waveform.

List Programming Example (Voltage Mode):

- 1) Press the front panel output button to make the product output a steady-state voltage.
- 2) See List programming data in Table 9

Table 9 List Programming Data Example Table

Sequence Number	No.1	No.2	No.3
Parameter Item	No.1	No.2	No.3
Amplitude [V]	100	250	50
Time[s]	0.1	0.1	0.1

See List programming example figure in Figure 162.

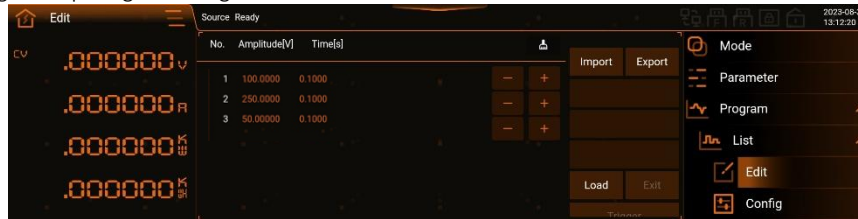

Figure 162 List Programming Example First Figure

- 3) Click 'Load' at the bottom right corner, at this time both 'Exit' and 'Trigger' are highlighted, see Figure 163

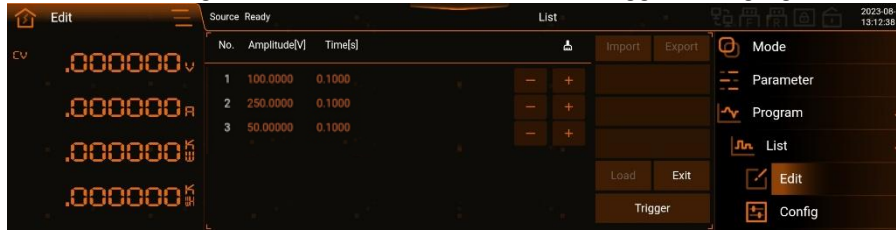

Figure 163 List Programming Example Second Figure

Note: Once loaded, programming data cannot be modified. To make changes, click 'Exit'.

Click 'Trigger' to display the programmed waveform on the oscilloscope, see Figure 164.

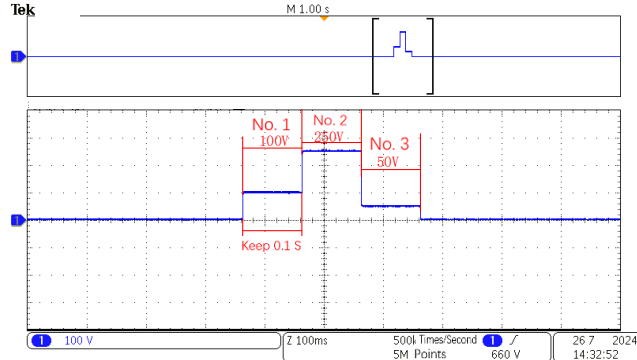

Figure 164 Example of List Programming Waveform Figure One

Note: At any time during the programming mode, you can click 'Exit' to end the current programming mode.

Click Programming-List-Configuration in the menu bar to enter the List mode configuration interface, see Figure 165.





Figure 165 List Configuration Interface Figure

The configuration interface allows you to change the number of cycles of the programmed waveform. For example, if the number of cycles of the List programmed waveform is set to 2, the programmed waveform is shown in Figure 166.

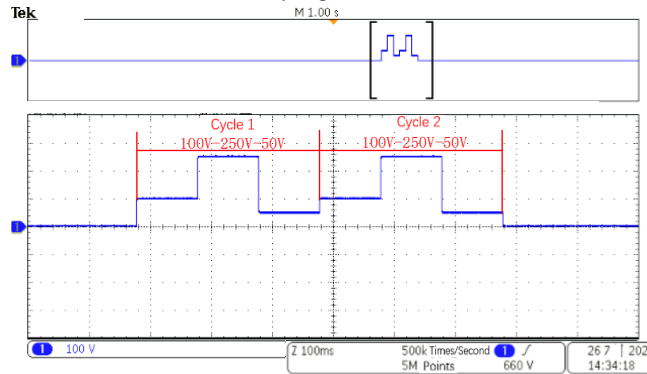

Figure 166 Example of List Programming Waveform Figure Two

The explanation of parameters in the configuration interface can be found in Table 10.

Table 10 List Configuration Interface Parameter Explanation Table

Parameter Item	Unit	Explanation and Application	Model	Resolution	Setting Range
Number of cycles	/	Set the number of cycles for the List programming waveform output. A cycle count of 0 indicates infinite looping.	ALL	/	0~9999999
Mode selection	/	<p>Voltage: When voltage is selected, the edited waveform is used for output voltage, and the maximum output current will be limited to Figure 157 the current setting value. If the voltage waveform appears distorted, adjust the amplitude to check if it is being limited.</p> <p>Current: When current is selected, the edited waveform is used for output current, and the maximum output voltage will be limited to Figure 157 the voltage setting value. If the current waveform appears distorted, adjust the amplitude to check if it is limited.</p> <p>Power: When power is selected, the edited waveform is used for output power, and the maximum output voltage will be limited to Figure 157 If the power waveform appears distorted at medium voltage settings, adjust the amplitude to check if it is being limited.</p> <p>Resistance: When selecting resistance, the edited waveform is used for output resistance, and the maximum output voltage will be limited at Figure 157 the voltage setting value. If the current waveform appears distorted, adjust the amplitude to check if it is being limited.</p>	ALL	/	/
Continuous Trigger	/	Once enabled, when the same programming data is triggered again, there is no need to click 'Load': simply click 'Trigger' directly.	ALL	/	/
Trigger Mode	/	Automatic: Execute sequentially according to the programming order. Single: Only one sequence is executed per trigger.	ALL	/	/

Configured List programming waveform data can be stored internally in the product or externally on a USB storage device for convenient recall next time, reducing the need for users to reconfigure. See Section 7.13.5.

The specific method for saving List programming waveform data in internal storage is as follows:

- 1) Click Figure 162 the 'Export' at the top right corner to enter the Figure 167 interface

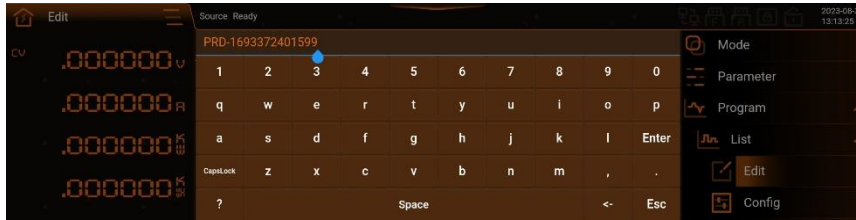

Figure 167 Waveform Export Interface Diagram

- 2) Enter the name of the file to be saved in the keyboard area and click 'Enter' to complete the saving.
- 3) Return to the List programming interface, click 'Import', and in the Figure 168 select the file just saved (with the suffix. list), click 'Confirm', and the saved waveform data will be imported into the List programming interface.

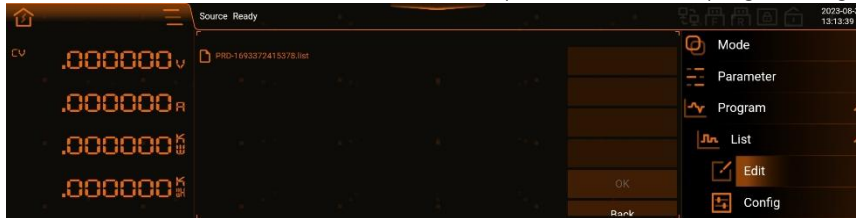

Figure 168 Waveform File Selection Interface

7.2.2 Wave

Wave includes two parts: editing and configuration, see Figure 169.

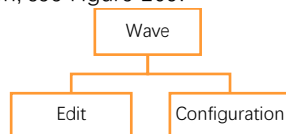

Figure 169 Wave Function Tree Diagram

Click Programming-Wave-Edit in the menu bar to enter the Wave programming interface, where you can set the Wave programming parameters yourself, see Figure 170. The explanation of parameters in the Wave programming interface is the same as in the List, see details.



Figure 170 Wave Programming Interface Diagram

Wave Programming Example (Voltage Mode):

- 1) Press the front panel output button to make the product output a steady-state voltage.

See Wave programming data in Table 11.

Table 11 Wave Programming Data Example Table

Sequence Number Parameter Item	No.1	No.2	No.3
Amplitude [V]	100	250	50
Time[s]	0.1	0.1	0.1

See Wave programming example diagram in Figure 171.



Figure 171 Wave Programming Example First Diagram

- 2) Click 'Load' at the bottom right corner, at this time both 'Exit' and 'Trigger' are highlighted, see Figure 172.



Figure 172 Wave Programming Example Second Diagram

Note: Once loaded, programming data cannot be modified. To make changes, click 'Exit'.

3) Click 'Trigger' to display the programmed waveform on the oscilloscope, see Figure 173.

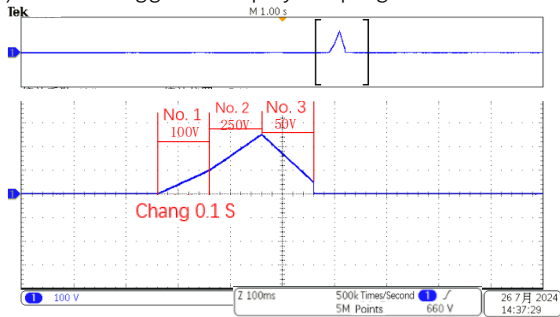

Figure 173 Wave Programming Waveform Example Diagram One

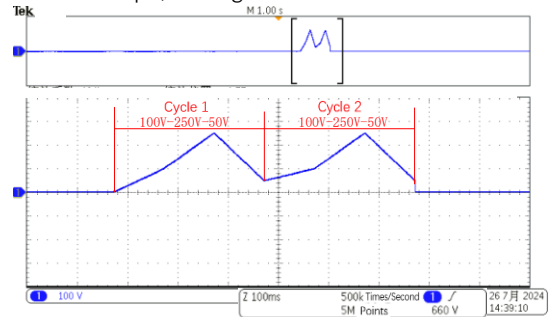

Figure 174 Wave Programming Waveform Example Diagram Two

Note: At any time during the programming mode, you can click 'Exit' to end the current programming mode.

Click Programming-Wave-Configuration in the menu bar to enter the Wave mode configuration interface. The parameters and functions of the Wave configuration interface are consistent with the List mode configuration interface, see Figure 165. In the configuration interface, set the loop count of the Wave programming waveform to 2, then the programming waveform is as shown in Figure 174.

The configured Wave programming waveform data can be stored inside the product or on an external USB storage device for easy retrieval next time, reducing the need for users to reconfigure. See Section 7.13.4.

The method for storing Wave programming waveform data inside the product is the same as the storage method for List programming. See Section 7.15.1.

7.2.3 Step

Step includes both editing and configuration sections. See Figure 175.

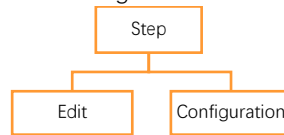

Figure 175 Step Function Tree Diagram

Click on Programming-Step-Edit in the menu bar to enter the Step programming interface, where you can set the Step programming parameters yourself. See Figure 176, for the explanation of each parameter, see Table 12.

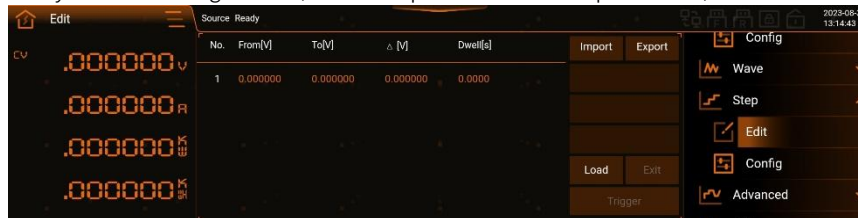

Figure 176 Step Programming Interface Diagram

Table 12 Explanation of Step Programming Interface Parameters

Parameter Item	Unit	Explanation	Model	Resolution	Setting Range
No.	/	The sequence number is 1.	ALL	/	/
Start [V]	V	The starting voltage amplitude of the sequence.	ALL	0.001	0~Maximum Voltage
Start [A]	A	The starting current amplitude of the sequence.	ALL	0.001	-Maximum Current ~Maximum Current
Start [kW]	kW	The starting power amplitude of the sequence.	ALL	0.001	-Maximum Power ~Maximum Power
Start [Ω]	Ω	The starting resistance amplitude of the sequence.	ALL	0.001	- Maximum Resistance ~Maximum Resistance
End [V]	V	The ending voltage amplitude of the sequence.	ALL	0.001	0~Maximum Voltage
End [A]	A	The ending current amplitude of the sequence.	ALL	0.001	-Maximum Current ~Maximum Current
End [kW]	kW	The ending power amplitude of the sequence.	ALL	0.001	-Maximum Power ~Maximum Power
End [Ω]	Ω	The ending resistance amplitude of the sequence.	ALL	0.001	- Maximum Resistance ~Maximum Resistance
Increment [V]	V	The voltage step increment value of the sequence, specifically referring to the change in voltage.	ALL	0.001	0~Maximum Voltage
Increment [A]	A	The current step increment value of the sequence, specifically referring to the change in current.	ALL	0.001	0 ~Maximum Current
Increment [kW]	kW	The power step increment value of the sequence, specifically referring to the change in power.	ALL	0.001	0 ~Maximum Power
Increment [Ω]	Ω	The resistance step increment value of the sequence, specifically referring to the change in resistance.	ALL	0.001	0 ~Maximum Resistance
Hold [s]	s	Step holding time.	ALL	0.01	0~999.9999

Parameter Item	Unit	Explanation	Model	Resolution	Setting Range
Import	/	Import the file containing stored data into the programming interface.	ALL	/	/
Export	/	Export the current programming data as a file and store it.	ALL	/	/
Load	/	Lock the programming data and enter the trigger-ready state.	ALL	/	/
Exit	/	At any time during programming mode, you can click 'Exit' to end the current programming mode.	ALL	/	/
Trigger	/	Transition from a stable output state to a programmed waveform output state.	ALL	/	/

Note: The expected output waveform is still influenced by the limit value parameters. Inappropriate limit settings may cause distortion of the expected output waveform.

Step Programming Example (Voltage Mode):

- 1) Press the front panel output button to make the product output a steady-state voltage.
- 2) See Step Programming Data Table 13.

Table 13 Step Programming Data Example Table

Parameter Item	Set Value	Parameter Item	Set Value
Start [V]	100	Increment [V]	100
End [V]	300	Hold[s]	0.1

See Step Programming Example Figure 177.



Figure 177 Step Programming Example First Figure

- 3) Click 'Load' at the bottom right corner, at this time both 'Exit' and 'Trigger' are highlighted, see Figure 143

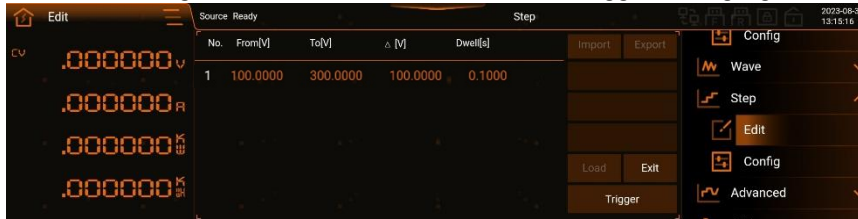

Figure 178 Step Programming Example Second Figure

Note: Once loaded, programming data cannot be modified. To make changes, click 'Exit'.

4) Click 'Trigger' to display the programmed waveform on the oscilloscope, see Figure 179.

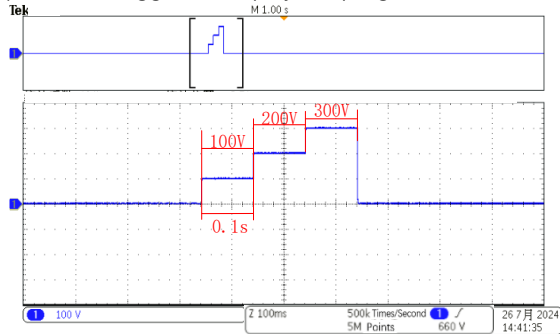

Figure 179 Step Programming Waveform Example First Figure

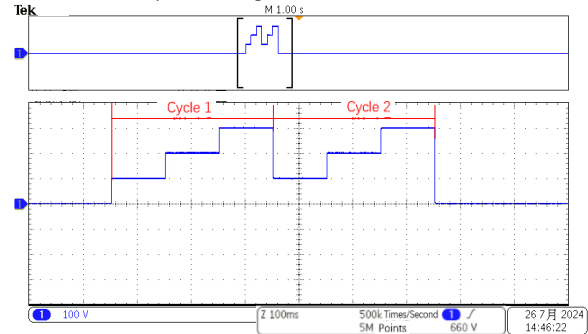

Figure 180 Step Programming Waveform Example Second Figure

Note: At any time during the programming mode, you can click 'Exit' to end the current programming mode.

Click on Programming-Step-Configuration in the menu bar to enter the Step mode configuration interface. The parameters and functions of the Step configuration interface are the same as those of the List mode configuration interface, see Figure 165. Set the loop count of the Step programming waveform to 2 in the configuration interface, then the programming waveform is as shown in Figure 180 the interface.

The configured Step programming waveform data can be stored inside the product or on an external USB storage device for easy recall next time, reducing the need for repeated configuration by the user, see Section 7.13.4.

The method for storing Step programming waveform data inside the product is the same as the storage method for List programming, see Section 7.2.1.

7.2.4 Advanced

Advanced function is an advanced programming feature of this product, allowing the editing of various waveforms to simulate complex working conditions. Advanced includes editing and configuration sections, see Figure 181.

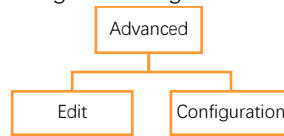

Figure 181 Advanced Function Tree Diagram

Click on Programming-Advanced-Edit in the menu bar to enter the Advanced Programming interface, where you can set Advanced Programming parameters, see Figure 182. See the explanation of each parameter Table 14.

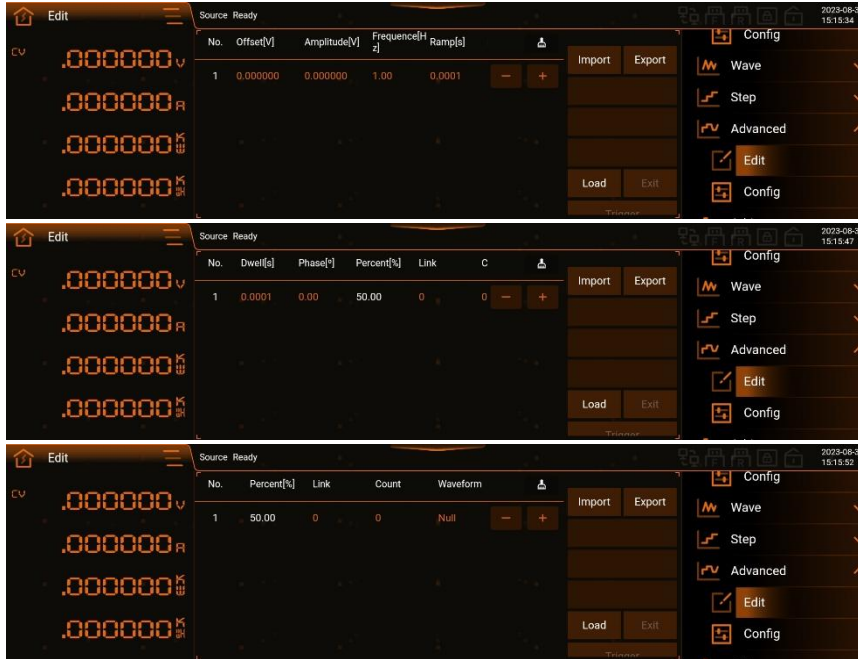



Figure 182 Advanced Programming Interface Diagram

Table 14 Advanced Programming Interface Parameter Definition Table

Parameter Item	Unit	Explanation	Model	Resolution	Setting Range
No.	/	Sequence Number.	ALL	/	1~100
Offset [V]	V	The DC component value of the voltage of the expected output waveform for this sequence.	ALL	0.001	0~Maximum Voltage
Offset [A]	A	The DC component value of the current of the expected output waveform for this sequence.	ALL	0.001	-Maximum Current ~Maximum Current
Amplitude [V]	V	The voltage amplitude of the expected output waveform, with a sine wave being half-peak and other waveforms being peak-to-peak. When setting, ensure the amplitude is always \leq the offset value. Otherwise, the output waveform may become distorted.	ALL	0.001	0~Maximum Voltage
Amplitude [A]	A	The current amplitude of the expected output waveform, with a sine wave being half-peak and other waveforms being peak-to-peak. When setting, ensure the amplitude is always \leq the offset value otherwise, the output waveform may become distorted.	ALL	0.001	-Maximum Current ~Maximum Current
Frequency [Hz]	Hz	The frequency of the expected output waveform.	ALL	0.01	0.01~10000
Change [s]	s	The change time from the previous No. sequence state to the current No. sequence state.	ALL	0.0001	0~999.9999
Hold [s]	s	The duration of the current No. sequence state.	ALL	0.0001	0~9999999
Phase [°]	°	Phase of the expected output waveform.	ALL	0.01	0~359.9°
Percentage [%]	/	Effective only when selecting pulse wave and triangle wave, corresponding to pulse wave duty cycle and triangle wave symmetry. Affected by device accuracy and bandwidth parameters, when smaller setting values are combined with higher frequencies, the device may not respond to the waveform. For example, when	ALL	0.01	0~100

Parameter Item	Unit	Explanation	Model	Resolution	Setting Range
		the pulse wave is 10 kHz with a 0.01% duty cycle, the minimum pulse width time is 1 μ s, and the device will not be able to output the expected waveform.			
Sequence combination	/	Combine the current No. sequence with the previous X sequences as a whole.	ALL	1	0~99
Number of repetitions	/	Number of times to repeat the sequence combination.	ALL	1	0~9999999
Waveform	/	Select the expected output waveform, which can be a sine wave, triangle wave, pulse wave, or one of Shape04~Shape30.	ALL	/	/
Clear ]	/	Clear all current programming data and return to Figure 182 the initial programming state.	ALL	/	/
“+”	/	Insert a new sequence after the current sequence, with parameter values identical to the current sequence.	ALL	/	/
“-”	/	Delete the current sequence.	ALL	/	/
Import	/	Import the file containing stored data into the programming interface.	ALL	/	/
Export	/	Export the current programming data as a file and store it.	ALL	/	/
Load	/	Lock the programming data and enter the trigger-ready state.	ALL	/	/
Exit	/	At any time during programming mode, you can click 'Exit' to end the current programming mode.	ALL	/	/
Trigger	/	Switch from a stable output state to a programmed waveform output state.	ALL	/	/

Note: The expected output waveform is still influenced by the limit value parameters. Inappropriate limit settings may cause distortion of the expected output waveform.

Advanced Programming Example (Voltage Mode):

- 1) Press the front panel output button to make the product output a steady-state voltage.
- 2) See Advanced Programming Data Table 15.

Table 15 Advanced Programming Data Example Table

Sequence Number Parameter Item	No.1	No.2	No.3
Offset [V]	200	200	200
Amplitude [V]	100	50	200
Frequency [Hz]	50	50	50
Change [s]	0.1	0.1	0.1
Hold[s]	0.2	0.2	0.2
Phase [°]	0	0	0
Percentage [%]	50	50	50
Sequence combination	0	0	0
Number of repetitions	1	1	1
Waveform	Sine Wave	Sine Wave	Sine Wave

See Advanced Programming Example Figure 183.

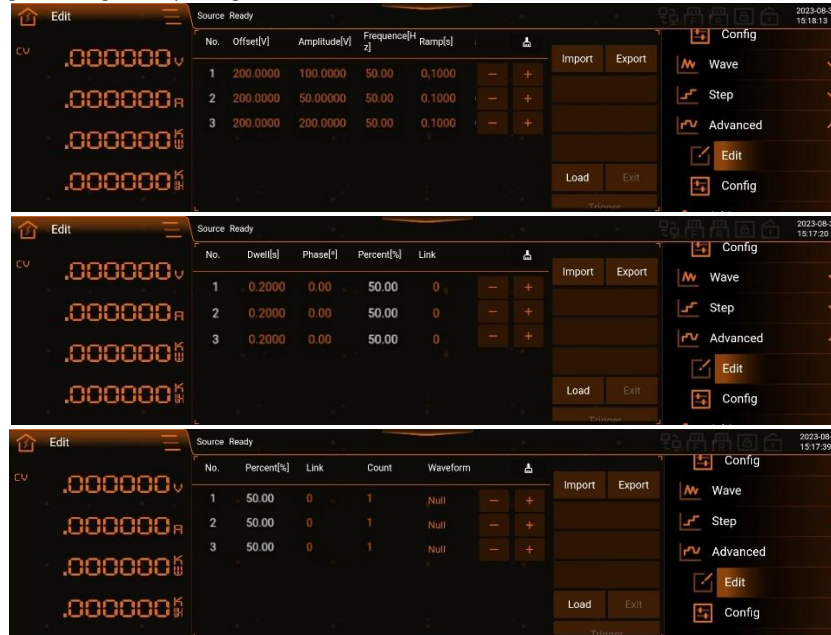

Figure 183 Advanced Programming Example First Figure

3) Click 'Load' at the bottom right corner, at this time both 'Exit' and 'Trigger' are highlighted, see Figure 184.

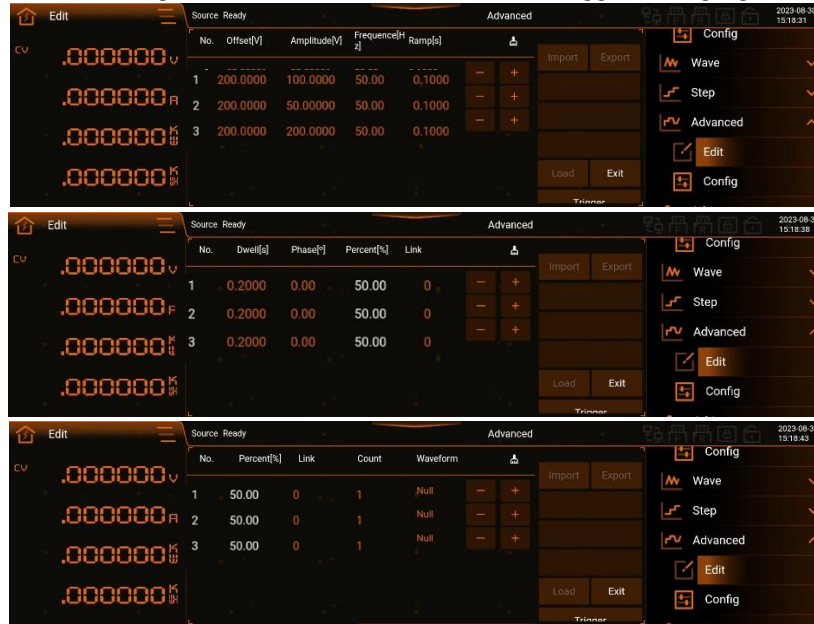

Figure 184 Advanced Programming Example Second Figure

Note: Once loaded, programming data cannot be modified. To make changes, click 'Exit'.

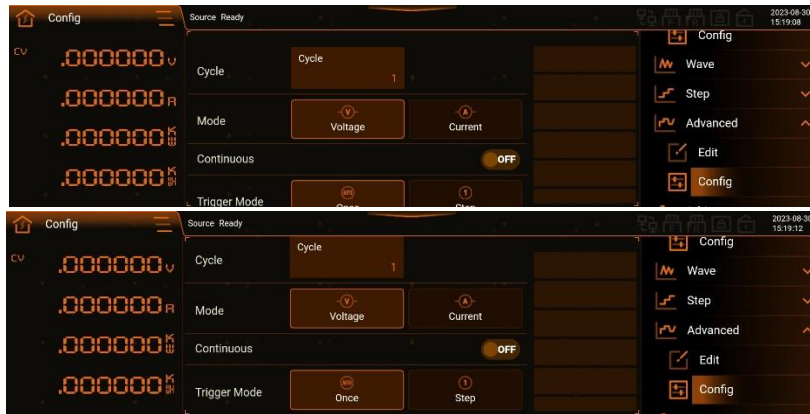

Figure 187 Advanced mode configuration interface diagram

The configured Advanced programming waveform data can be stored inside the product or on an external USB storage device for easy retrieval next time, reducing the need for repeated configuration by the user, as detailed in section 7.13.5.

The specific method for storing Advanced programming waveform data inside the product can refer to the storage method of List programming, as detailed in section 7.2.1.

The table below shows the sine wave amplitude-frequency characteristics of the Advanced programming output voltage and current. The voltage amplitude-frequency characteristic curve is measured under no-load (open circuit) conditions, with three curves corresponding to three response speeds. The current amplitude-frequency characteristic curve is measured under resistive load conditions.

Table 16 Amplitude-Frequency Characteristic Curve Area Table

Model	Voltage Sine Wave Amplitude-Frequency Characteristic Curve	Current Sine Wave Amplitude-Frequency Characteristic Curve
CD30-1K5B CD30-1K5A CD30-2K0B CD30-2K0A		
		

Table 17 Amplitude-Frequency Characteristic Curve Area Table

Model	Voltage Sine Wave Amplitude-Frequency Characteristic Curve	Current Sine Wave Amplitude-Frequency Characteristic Curve
CD30-800B CD30-800A CD30-1K0B CD30-1K0A CD15-800B CD15-800A CD20-800B CD20-800A CD15-1K0B CD15-1K0A CD20-1K0B CD20-1K0A	 <p>The graph shows Voltage Amplitude/dB on the y-axis (ranging from -35 to 5) and Frequency/Hz on the x-axis (logarithmic scale from 10 to 10000). Three curves are plotted: Fast (blue), Medium (orange), and Slow (green). All curves start at 0 dB at 10 Hz. The Fast curve begins to roll off around 500 Hz, reaching approximately -15 dB at 10000 Hz. The Medium curve begins to roll off around 200 Hz, reaching approximately -25 dB at 10000 Hz. The Slow curve begins to roll off around 100 Hz, reaching approximately -30 dB at 10000 Hz.</p>	 <p>The graph shows Current Amplitude/dB on the y-axis (ranging from -30 to 5) and Frequency/Hz on the x-axis (logarithmic scale from 10 to 10000). A single blue curve is plotted, starting at 0 dB at 10 Hz. It remains flat until about 500 Hz, then begins to roll off, reaching approximately -25 dB at 10000 Hz.</p>

Table 18 Amplitude-Frequency Characteristic Curve Area Table

Model	Voltage Sine Wave Amplitude-Frequency Characteristic Curve	Current Sine Wave Amplitude-Frequency Characteristic Curve
CD15-040B CD15-040A CD15-060B CD15-060A CD15-080B CD15-080A CD20-040B CD20-040A CD20-060B CD20-060A CD20-080B CD20-080A	 <p>The graph shows Voltage Amplitude/dB on the y-axis (ranging from -100 to 20) and Frequency/Hz on the x-axis (logarithmic scale from 10 to 10000). Three curves are shown: Fast (blue), Medium (red), and Slow (green). All curves start at 0 dB at 10 Hz and remain flat until approximately 500 Hz. The Fast curve drops to about -40 dB at 10000 Hz, the Medium curve to about -50 dB, and the Slow curve to about -70 dB.</p>	 <p>The graph shows Current Amplitude/dB on the y-axis (ranging from -45 to 5) and Frequency/Hz on the x-axis (logarithmic scale from 10 to 10000). A single blue curve is shown. It remains flat at 0 dB until approximately 500 Hz, then drops to about -40 dB at 10000 Hz.</p>

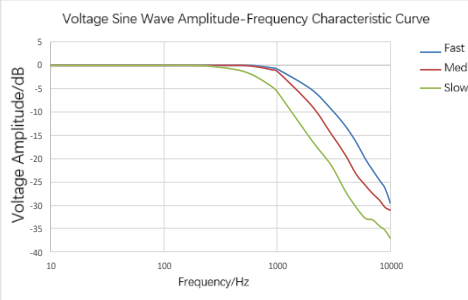
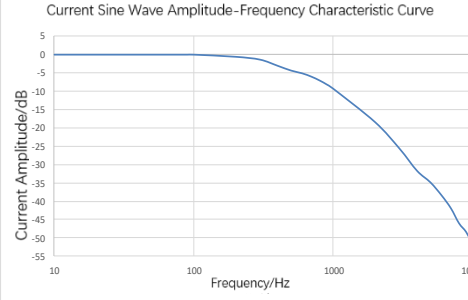
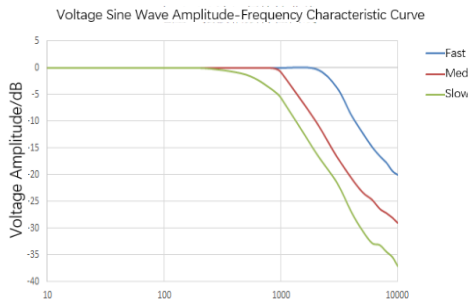
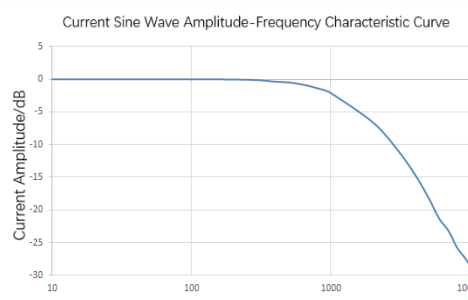
Note: This characteristic also applies to the condition of arbitrary wave programming output sine wave.

7.2.5 Arbitrary Wave

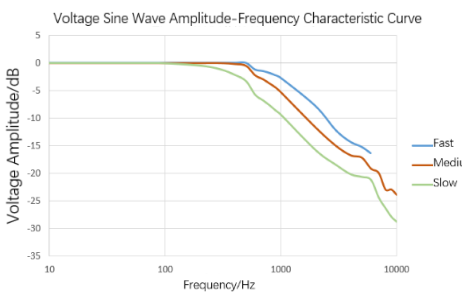
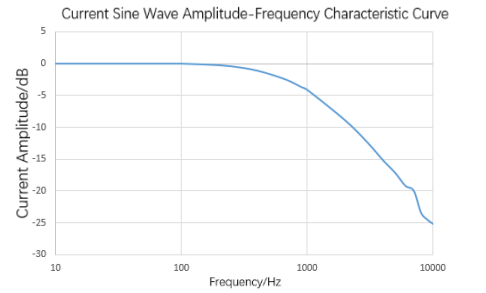
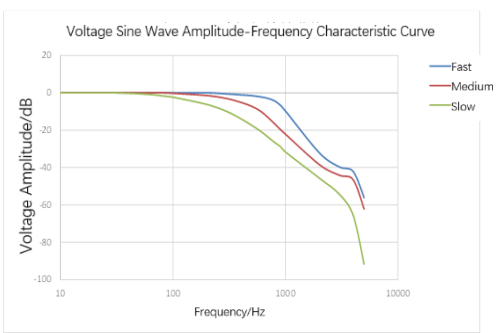
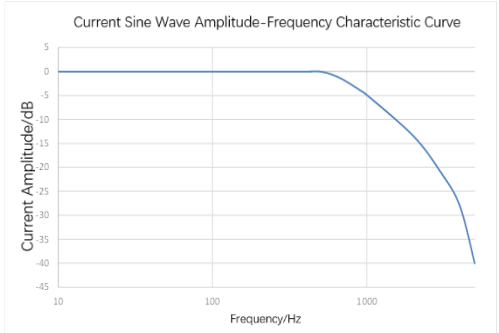
The Arbitrary Wave function is an advanced programming feature of CD-B, allowing the editing of various waveforms to simulate complex conditions. The Arbitrary Wave includes both editing and configuration components, see

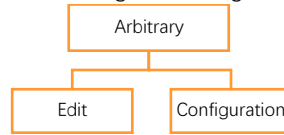

Figure 188 Arbitrary Wave Function Tree Diagram

Click on Programming - Arbitrary Wave - Edit in the menu bar to enter the Arbitrary Wave programming interface, see Figure 189, you can set the arbitrary wave programming parameters yourself. See the explanation of each parameter in Table 19.

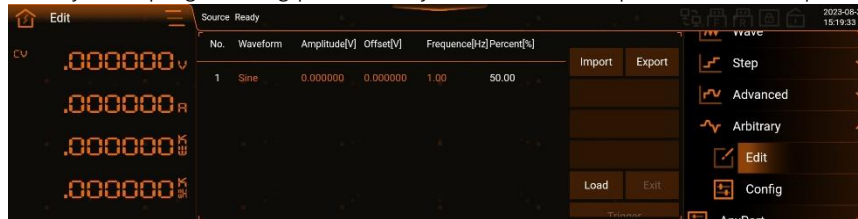



Figure 189 Arbitrary Wave Programming Interface Diagram

Table 19 Explanation of Arbitrary Wave Programming Interface Parameters

Parameter Item	Unit	Explanation	Model	Resolution	Setting Range
No.	/	Sequence Number.	ALL	/	1~200
Waveform	/	The expected output waveform can be selected as one of the sine waves, triangle wave, pulse wave, Shape04~Shape30.	ALL	/	/
Amplitude [V]	V	The voltage amplitude of the expected output waveform, with a sine wave being half-peak and other waveforms being peak-to-peak. When setting, ensure the amplitude is always \leq the offset value. Otherwise, the output waveform may become distorted.	ALL	0.001	0~Maximum Voltage
Amplitude [A]	A	The current amplitude of the expected output waveform, with a sine wave being half-peak and other waveforms being peak-to-peak. When setting, ensure the amplitude is always \leq the offset value. Otherwise, the output waveform may become distorted.	ALL	0.001	Maximum Current~Maximum Current
Offset [V]	V	The DC component value of the expected output waveform's voltage.	ALL	0.001	0~Maximum Voltage
Offset [A]	A	The DC component value of the expected output waveform's current.	ALL	0.001	Maximum Current ~ Maximum Current
Frequency [Hz]	Hz	The frequency of the expected output waveform.	ALL	0.01	0.01~10000
Percentage [%]	/	Parameters specific to pulse wave and triangle wave only, corresponding to the duty cycle of the pulse wave and the symmetrical triangle wave. Affected by device accuracy and bandwidth parameters, when smaller setting values are combined with higher frequencies, waveforms that the device cannot respond to may occur. When the pulse wave is 10k Hz with	ALL	0.01	0~100

Parameter Item	Unit	Explanation	Model	Resolution	Setting Range
		a 1% duty cycle, the minimum pulse width time is 1 μ s, and the device will not be able to output the expected waveform.			
Clear 	/	Clear all current programming data and return to Figure 189 the initial programming state.	ALL	/	/
“+”	/	Insert a new sequence after the current sequence, with parameter values identical to the current sequence.	ALL	/	/
“-”	/	Delete the current sequence.	ALL	/	/
Import	/	Import the file containing stored data into the programming interface.	ALL	/	/
Export	/	Export the current programming data as a file and store it.	ALL	/	/
Load	/	Lock the programming data and enter the trigger-ready state.	ALL	/	/
Exit	/	At any time during programming mode, you can click 'Exit' to end the current programming mode.	ALL	/	/
Trigger	/	Switch from a stable output state to a programmed waveform output state.	ALL	/	/

Note: The expected output waveform is still influenced by the limit value parameters. Inappropriate limit settings may cause distortion of the expected output waveform.

Arbitrary Wave Programming Example (Voltage Mode):

- 1) Press the front panel output button to make the product output a steady-state voltage.
- 2) See Arbitrary Wave Programming Data Table 20, see Arbitrary Wave Programming Example Figure 190.

Table 20 Arbitrary Wave Programming Data Example Table

Sequence Number Parameter Item	Waveform	Amplitude [V]	Offset [V]	Frequency [Hz]	Percentage [%]
No.1	Sine Wave	200	200	50	50

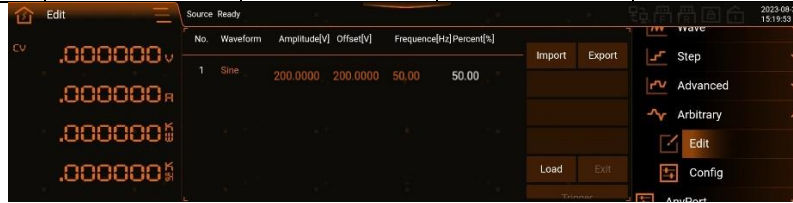

Figure 190 Arbitrary Wave Programming Example One

- 3) Click 'Load' at the bottom right corner, at this time both 'Exit' and 'Trigger' are highlighted, see Figure 191

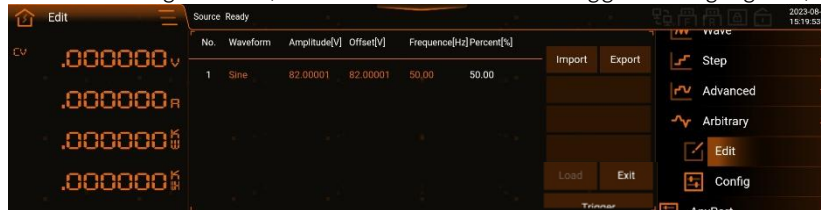

Figure 191 Arbitrary Wave Programming Example Two

Note: Once loaded, programming data cannot be modified. To make changes, click 'Exit'.

- 4) Click 'Trigger' to display the programmed waveform on the oscilloscope, see Figure 192

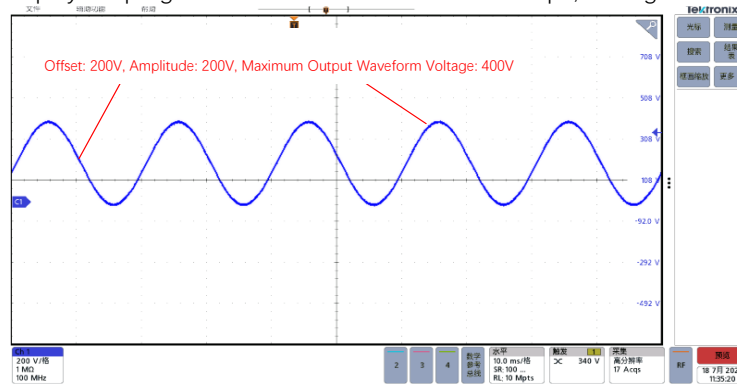

Figure 192 Arbitrary Wave Programming Waveform Example Figure

Note: At any time during the programming mode, you can click 'Exit' to end the current programming mode.

Click on Programming - Arbitrary Wave - Configure in the menu bar to enter the Arbitrary Wave Mode Configuration Interface, see Figure 193.

When selecting voltage, the edited waveform is used for output voltage, and the maximum output current will be limited to Figure 158 the current setting value. If the voltage waveform appears distorted, adjust the amplitude to check if it is being limited. When selecting current, the edited waveform is used for output current, and the maximum output voltage will be limited to Figure 158

the voltage setting value. If the current waveform appears distorted, adjust the amplitude to check if it is limited.



Figure 193 Arbitrary Wave Mode Configuration Interface Diagram

The configured arbitrary wave programmed waveform data can be stored in the product internally or in an external USB storage device for easy retrieval next time, reducing the need for users to configure repeatedly. See Section 7.13.5.

The specific method for storing arbitrary wave programmed waveform data internally can refer to the storage method of List programming

7.3 Anyport

Anyport includes both digital and analog parts, see Figure 194. Each enable switch corresponds to an Anyport interface pin, so ensure one-to-one correspondence during use.

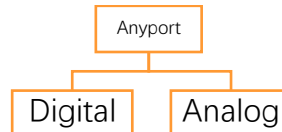

Figure 194 Anyport Function Tree Diagram

7.3.1 Digital

Click Anyport-Digital in the menu bar to enter the digital settings interface.

7.3.1.1 Digital Input

See Anyport Digital Input Settings Interface Figure 195, which can achieve external given enable, trigger, interlock, start-stop, reset, and emergency stop functions under positive/negative polarity. For details on the digital input function, see Table 21.



Figure 195 Digital Input Settings Interface Diagram

Table 21 Digital Input Function Definition Table

Interface Type	Interface Name	Function Definition
Digital Input	Input 1 [Port19]	Polarity: Select the valid level. 1) Positive: High level is valid. High level Range is 3V~10V, Pulse width must be > 50μs. 2) Negative: Low level is valid. Low level Range is < 1V, Pulse width must be > 50μs. Function 1) None: Digital input interface not enabled. 2) External given enable: Enable analog input function.
	Input 2[Port20]	
	Input 3[Port21]	
	Input 4[Port22]	

	Input 5[Port10]	3) Trigger: Use external pulse signal to trigger List, Wave, Step, Advanced, Arbitrary Wave programming, needs to be set in section 7.12set trigger input to external.
	Input 6[Port11]	4) Interlock: Interlock shutdown. 5) Start/Stop: Use external level signal, start when valid, stop when invalid. 6) Reset: Use external pulse signal (pulse width above 50μs) to reset. 7) Emergency Stop: Use external level signal for emergency stop.

7.3.1.2 Digital Output

See Anyport digital output interface Figure 196, can achieve interlock, trigger, voltage indication, current indication, and general I/O functions under positive/negative polarity, while also monitoring the product's operating status, CV status, and protection status. For details on the digital output function, see Table 22.



Figure 196 Digital Output Setting Interface Diagram

Table 22Anyport Output Function Table

Interface Type	Interface Name	Function Definition
Digital Output	Output 1 [Port1]	Polarity: Select the valid level. 1) Positive: Active high. The high-level amplitude is determined by the external voltage.

Interface Type	Interface Name	Function Definition
	Output 2[Port2]	2) Negative: Low level is valid. Function
	Output 3[Port3]	1) Interlock: Output protection signal. 2) Trigger: When the output is turned on and off, steady state setpoint changes, or programming trigger output occurs, a pulse signal of 40~ 50 μ s is generated.
	Output 4[Port4]	3) Voltage Indication: Voltage External Setpoint Signal. When the user needs to indicate the voltage given method as external, the voltage indication function can be enabled. When the external voltage given function is enabled, the output port outputs an active level.
	Output 5[Port14]	4) Current Indication: External current given signal. When the user needs to indicate the current given method as external, the current indication function can be enabled. When the external current given function is enabled, the output port outputs an active level.
	Output 6[Port15]	5) General I/O: General High, Low level signal. When the user needs general I/O to control external devices, the general I/O function can be enabled. By setting the polarity, the output port can control the high- and low-level signals. 6) Operating Status: When the output is connected, it always outputs an active level. 7) CV Status: Constant voltage status indicator. 8) Protection Status: When the product is protected, it always outputs an active level.

7.3.2 Analog

Click Anyport-Simulation in the menu bar to enter the simulation settings interface, see Figure 197, the simulation function is effective after being externally enabled on any interface of the digital input. Anyport simulation function can be externally enabled to set the output values of this product in the settings area through voltage, current, power, and resistance external settings, remote setting. For details on the simulation input function, see Table 23.



Figure 197 Simulation Function Settings Interface Diagram

Table 23 Simulation Function Definition Table

Function	Name	Function Definition
Analog	Analog Given Range	The rated range for the external given analog quantity is set, and you can choose 5 V or 10V. The rated range corresponds to the rated values of voltage/ current/power/ internal resistance of this product. Example: When the 10 V range is selected, and the external voltage given is 0~ 10 V, it corresponds to the output setting area voltage of 0~2000V (CDXX-2K0B model). See the table of analog given ranges. Table 24.
	Voltage External Given	After enabling, the voltage can be set through the external given voltage via the Anyport interface.
	Current External Given	After enabling, the current can be set through the external given voltage via the Anyport interface.
	External Power Setting	After enabling, the power can be set by externally providing voltage through the Anyport interface.
	External Internal Resistance Setting	After enabling, the internal resistance can be set by externally providing voltage through the Anyport interface.

Table 24 Corresponding Table of

Analog Given Range	External Analog Range	External Setting Object	Output Setting Range
5V	0~5V	Voltage	0~Rated Voltage
		Current	0~Rated Current
		Power	0~Rated Power
		Internal Resistance	0~Rated Internal Resistance
10V	0~10V	Voltage	0~Rated Voltage
		Current	0~Rated Current
		Power	0~Rated Power
		Internal Resistance	0~Rated Internal Resistance

7.4 SAS (Solar Array Simulator)

CD-B has SAS solar cell simulator function. Due to interface and operation limitations, the built-in SAS function of the device only supports simple curve operations. More functions require the cooperation of the 'Programmable Power Supply Virtual Terminal' software, which can achieve comprehensive testing functions in the photovoltaic industry. Its high-precision measurement and control system can more accurately test the maximum tracking efficiency of solar inverters.

The SAS function requires the insertion of a Magic-Box component with SAS functionality and selecting SAS mode in the menu bar-mode interface to activate and use it, see Section 7.6, function as Figure 198.

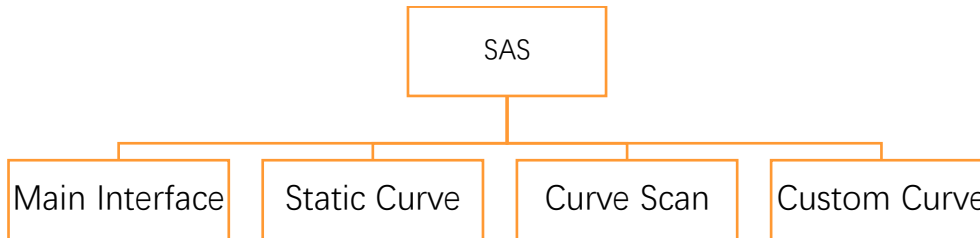

Figure 198 SAS Function Tree Diagram

7.4.1 SAS Main Interface

The SAS Solar Cell Simulator function can simultaneously simulate P-V and I-V curves and dynamically display the tracking status in a box format. The data on the right can display the curve values under the selected model. SAS Main Interface see Figure 199.

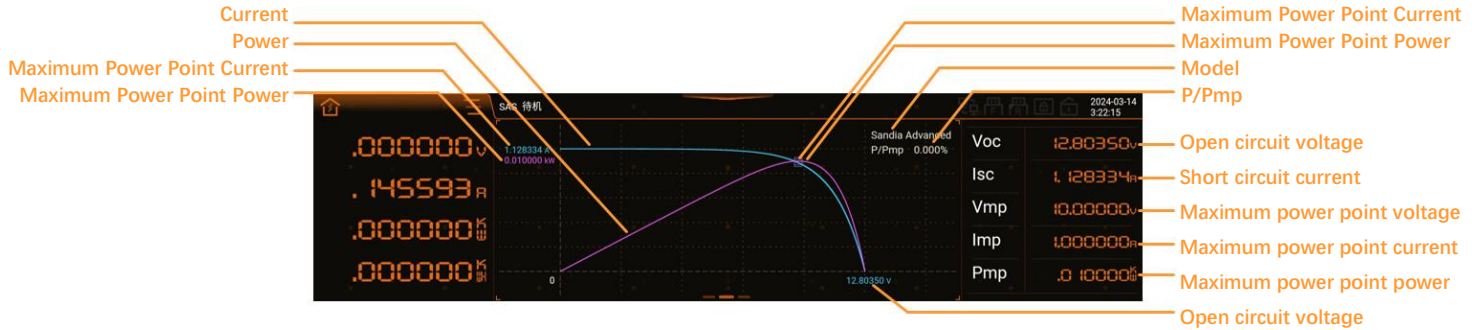

Figure 199 SAS Main Interface Diagram

7.4.2 SAS Static Curve

SAS has five curve models see Figure 200, namely Sandia Basic, Sandia Advanced, EN50530 Basic, EN50530 Advanced, Simple, suitable for most application scenarios.



Figure 200 Curve Model Interface Diagram

Sandia Basic Model, EN50530 Basic Model, and Simple Model can quickly generate I-V curves as seen Figure 201, see the function of each parameter Table 25.



Figure 201 Curve Parameter Interface Diagram (Sandia Basic, EN50530 Basic, Simple)

Table 25 Curve Parameter Function Table (Sandia Basic, EN50530_Basic, Simple)

Parameters	Unit	Explanation and Application	Model	Resolution	Initial Value	Setting Range
Vmp	V	Voltage at the maximum power point.	ALL	0.00001	10.00000	0 ~Rated Voltage
Voc	v	Open Circuit Voltage.	ALL	0.00001	12.00000	Vmp~ Rated Voltage
Imp	A	Current at the maximum power point.	ALL	0.00001	1.00000	0~ Rated Current
Isc	A	Short Circuit Current.	ALL	0.00001	1.50000	Imp~ Rated Current
Pmp	kW	Power at the Maximum Power Point.	ALL	0.00001	10.000	0~ Rated Power

The Sandia Advanced model supports changing external parameters to generate curves, simulating more realistic working conditions. See the curve parameter interface of the Sandia Advanced model Figure 202, Functions of each parameter as Table 26.



Figure 202 Curve Parameter Interface Diagram (Sandia Advanced)

Table 26 Curve Parameter Functions Table (Sandia_ Advanced)

Parameters	Unit	Explanation and Application	Model	Resolution	Initial Value	Setting Range
Pmp	kW	Power at the Maximum Power Point.	ALL	0.000001	0.010000	0.000~ Rated Power
Irr	w/m ²	Solar Irradiance Rate.	ALL	0.01	1000.00	0~3000
Vmp	V	Voltage at the Maximum Power Point.	ALL	0.00001	10.00000	0.00000~ Rated Voltage
T	°C	Solar Cell Module Temperature.	ALL	0.01	50.00	-40~150
FF	/	Fill Factor, defined as $FF = \frac{V_{mp} \cdot I_{mp}}{V_{oc} \cdot I_{sc}}$.	ALL	0.01	0.68	0.3~0.95
Irr.ref	w/m ²	Solar irradiance under reference or rated conditions.	ALL	0.01	1000.00	0~3000
β	%/°C	Temperature coefficient. This parameter affects the extent to which current and voltage need to be scaled due to changes in battery pack temperature.	ALL	0.01	-0.38	-2.00~0.00
T.ref	°C	Temperature of the solar cell module under reference or rated conditions.	ALL	0.01	50.00	-40~150
Import	/	Import the file containing stored data into the curve parameters interface.	ALL	/	/	/
Export	/	Export the current curve parameters data as a file and store it.	ALL	/	/	/
PV Tech button	/	This button allows you to view the recommended FF and β parameter settings for different solar panels. For the P V Tech button interface, see Figure 203.	ALL	/	/	/
Update button	/	Update the curve model, parameters, and settings from the static curve to the product's processing system. You can view the updated curve in the function editing area.	ALL	/	/	/



Figure 203 PV Tech (Sandia_ Advanced)

This product can generate I-V curves under the EN50530 Advanced model through advanced parameters. The curve parameter interface of the EN50530 Advanced model is shown in Figure 204, and the functions of each parameter are shown as Table 27.



Figure 204 Curve Parameter Interface Diagram (EN50530 Advanced)

Table 27 Curve Parameter Functions Table (Sandia_ Advanced)

Parameters	Unit	Explanation and Application	Model	Resolution	Initial Value	Setting Range
Pmp	kW	Power at the Maximum Power Point.	ALL	0.001	0.010	0.000~ Maximum Power
Irr	w/m ²	Solar Irradiance Rate.	ALL	0.001	1000.000	0~3000
Vmp	V	Voltage at the Maximum Power Point.	ALL	0.001	10.000	0.000~ Maximum
T	°C	Solar Cell Module Temperature.	ALL	0.001	25.000	-40~150
Irr.stc	w/m ²	Solar irradiance under standard test conditions.	ALL	/	/	/
T.stc	°C	Solar irradiance under standard test conditions.	ALL	/	/	/
PV Tech	/	Select the solar panel material as one of c-Si, Thin-	ALL	/	c-Si	/
Import	/	Import the file containing stored data into the curve	ALL	/	/	/
Export	/	Export the current curve parameters data as a file	ALL	/	/	/
PV Tech	/	This button can view the recommended parameter	ALL	/	/	/
Update button	/	Update the curve model, parameters, and settings from the static curve to the product's processing system. You can view the updated curve in the function editing area.	ALL	/	/	/

This product offers three PV Tech, namely c-Si, Thin-Film, and User. The relevant parameters for c-Si and Thin-film are preset values of the product, which cannot be changed by the user. The curve parameter interface for c-Si can be seen in Figure 205, the curve parameter interface for Thin-film can be seen in Figure 206. The parameter definitions for PV Tech can be seen in Table 28.



Figure 205 PV Tech (EN50530_Advanced, c-Si)



Figure 206 PV Tech (EN50530 Advanced, Thin-film)

All relevant parameters of the User solar panel can be changed, and users can customize settings as needed. The curve parameter interface for User can be seen in Figure 207. The parameter definitions for PV Tech can be seen in Table 28



Figure 207 PV Tech (EN50530 Advanced, User)

Table 28P V Tech Parameter Definition Table

Parameters	Unit	Explanation and Application	Model	Resolution	Initial Value (User)	Setting Range (User)
FFu	/	Open Circuit Voltage Ratio, $FF_u = \frac{U_{MPP.stc}}{U_{OC.stc}}$	ALL	0.001	0.800	0.300~0.950
FFi	/	Short Circuit Current Ratio, $FF_i = \frac{I_{MPP.stc}}{I_{SC.stc}}$	ALL	0.001	0.905	0.300~0.950
CG	w/m ²	Correction Factor.	ALL	0.001	2.514	0.100~9.999
CV	w/m ²	Correction Factor.	ALL	0.001	8.593	0.100~99.999
CR	w/m ²	Correction Factor.	ALL	0.001	1.088	0.100~9.999
α	%/°C	Current Temperature Coefficient.	ALL	0.001	0.040	0.000~1.000
β	%/°C	Voltage Temperature Coefficient.	ALL	0.001	-0.400	-2.000~0.000

This product can set advanced parameters of the curve, see the advanced settings interface Figure 208.



Figure 208 SAS Advanced Settings Interface Figure

The functions of each parameter are as follows:

Measurement Period: The interval between two data measurements, the initial value is 0.200, range is 0.010 ~ 1.000.

End Hold: Applicable to curve scanning experiments, sets the state of the device after the curve scan is completed. After enabling,

the curve scan experiment ends, the working point will remain at the curve at the end time.

S Standardization: Sandia Mode Standardization. When using Sandia mode to generate standardized curves, Sandia mode will scale the set parameters by a certain ratio to provide the specified voltage and power under appropriate test conditions, which will result in the actual parameters in the function edit area under Sandia mode being inconsistent with the parameter values set in the curve parameters. Enable S Standardization, the system will correct the actual parameters of the I-V curve under Sandia mode to the set values of the curve parameters.

7.4.3 SAS Curve Scan

Curve scanning is an experiment that adjusts the curve based on the percentage of open-circuit voltage and short-circuit current on the basis of a static curve. It can also be scaled according to irradiation and temperature to simulate the MPPT efficiency of a solar cell array under dynamic weather conditions, allowing users to test photovoltaic inverter characteristics more accurately, see Figure 209.





Figure 209 Curve Scanning Percentage Interface Diagram

Each Parameter Function See Table 29.

Table 29 Curve Scanning Percentage Parameter Function Table

Parameters	Unit	Explanation and Application	Model	Resolution	Initial Value	Setting Range
Scanning Mode	/	The method of curve scanning can be selected as either percentage or advanced.	ALL	/	Percentage	/
Scan Time	s	Total Duration of Curve Scan.	ALL	1	0	1~86400
Switching Rate	s	Switching time per step from start to finish.	ALL	0.001	0.100	0.001~1.000
V Start	%	Set the percentage of open-circuit voltage Voc at the start.	ALL	0.01	100.00	1~100.00
V End	%	Set the percentage of open-circuit voltage Voc at the end.	ALL	0.01	100.00	1~100.00
I Start	%	Set the percentage of short-circuit current Isc at the start.	ALL	0.01	100.00	1~100.00
I End	%	Set the percentage of short-circuit current Isc at the end.	ALL	0.01	100.00	1~100.00
Import	/	Import the file containing stored data into the curve parameters interface.	ALL	/	/	/

Parameters	Unit	Explanation and Application	Model	Resolution	Initial Value	Setting Range
Export	/	Export the current curve parameters data as a file and store it.	ALL	/	/	/
V<-> Button	/	Swap the values of V Start and V End.	ALL	/	/	/
I<-> Button	/	Swap the values of I Start and I End.	ALL	/	/	/
Start Button	/	Update static curve parameters and start the curve scanning	ALL	/	/	/

Advanced functions are used to set analog light and temperature dynamic curve scanning, only when the static curve is Sandia Advanced, EN50530 Advanced, can the scanning mode use advanced functions, see the advanced function interface Figure 210. See the explanation of advanced function parameters Table 30.

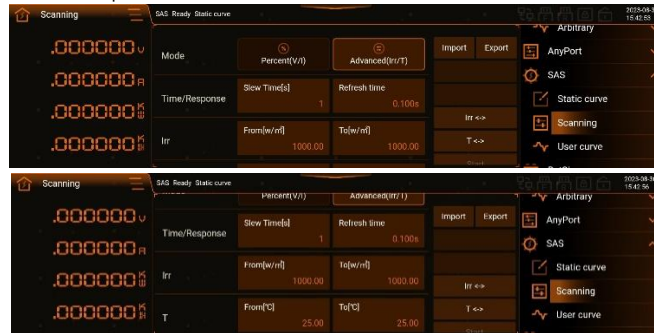

Figure 210 Curve Scanning Advanced Interface Diagram

Table 30 Curve Scanning Advanced Parameter Function Table

Parameters	Unit	Explanation and Application	Model	Resolution	Initial Value	Setting Range
Scanning Mode	/	The method of curve scanning can choose percentage or advanced.	ALL	/	Percentage	/
Scanning Time	/	Total duration of curve scanning.	ALL	1	0	1~86400
Switching Rate	s	Switching time per step from start to finish.	ALL	0.001	0.1	0.001~1
Illumination Start	w/m ²	Set the starting illumination percentage, where illumination is the static curve parameter Irr.	ALL	0.01	1000	0~3000
Illumination End	w/m ²	Set the ending illumination percentage, where illumination is the static curve parameter Irr.	ALL	0.01	1000	0~3000
T Start	°C	Set the starting temperature percentage, where temperature is the static curve parameter T.	ALL	0.01	25	-40~150
T End	°C	Set the ending temperature percentage, where temperature is the static curve parameter T.	ALL	0.01	25	-40~150
Import	/	Import the file containing stored data into the curve parameters interface.	ALL	/	/	/
Export	/	Export the current curve parameters data as a file and store it.	ALL	/	/	/
V<-> Button	/	Swap the values of V start and V end.	ALL	/	/	/
I<-> Button	/	Swap the I start and I end values.	ALL	/	/	/
Start Button	/	Update static curve parameters and start the curve scan test.	ALL	/	/	/

7.4.4 SAS Custom Curve

Users can generate non-standard I- V curves using the Custom Curve mode. The advantage of using the Custom Curve mode is that users are no longer limited by the Sandia or EN505 30 models. By using an external USB storage device, the edited curves can be imported into the internal storage of this product. For details, see section 7.13.5.

Press 'Import' to import the selected internal storage file to the display screen, where the parameters in the file will be shown. The screen will display 'Data Importing...', and if the operation is successful, it will show 'Data Import Successful!'. The imported curve can be activated by pressing the update button.

Press 'Export' to export the selected custom curve data to the internal storage file. The screen will display 'Exporting data...'. If the operation is successful, it will display 'Data export success!'. After a successful export, the display will refresh the file list. Users can export the edited curve to an external USB storage device. See Section 7.13.5.

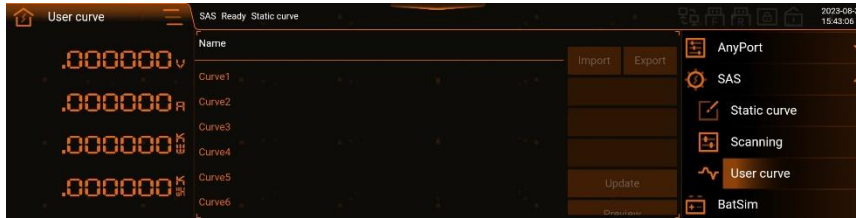

Figure 211 Custom Curve Interface Diagram

7.5 BatSim (Battery Simulator)

CD-B features the BatSim battery simulator function. Due to interface and operation limitations, the product's built-in BatSim function only supports the Basic mode of the battery model. To use the Advanced and User modes, the 'Programmable Power Supply Virtual Terminal' software is required. CD-B features a high-precision measurement system and a high-speed computing unit, which can more realistically and accurately simulate different types of batteries.

The BatSim function requires the insertion of a Magic-Box component with BatSim functionality and selecting the BatSim mode in the menu bar-mode interface to activate and use it, see 7.6 section, see the function tree diagram in Figure 212.

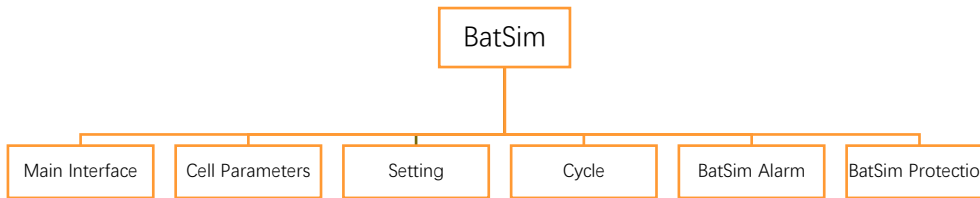

Figure 212 BatSim Function Tree Diagram

7.5.1 Main Interface

See the BatSim main interface in Figure 213.

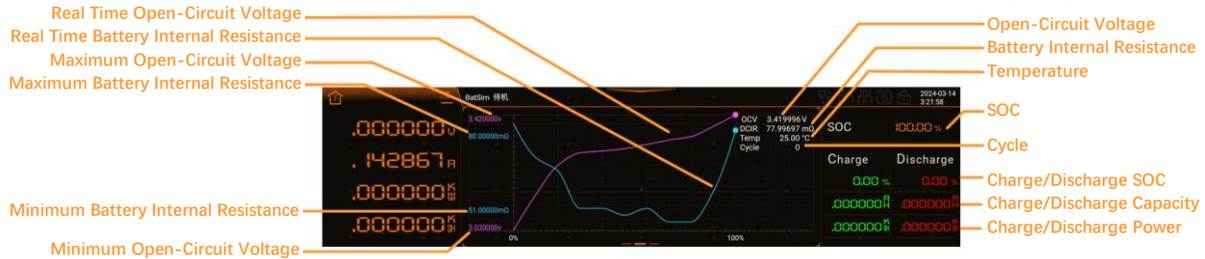

Figure 213 BatSim Main Interface Diagram

7.5.2 Cell Parameters

BatSim cell parameters include mode, battery technology, initial SOC, internal resistance, initial capacity, capacity, initial temperature, number of series, cable impedance, and number of parallels. See the cell parameters interface in Figure 214. Single cell parameter function definition sees Table 31



Figure 214 Single cell parameter interface Figure

Table 31 Single cell parameter function table

Parameters	Unit	Explanation and Application	Model	Resolution	Initial Value	Setting Range
Battery Technology	/	Includes lithium iron phosphate, ternary lithium, lithium titanate, lithium manganese oxide, lithium cobalt oxide, nickel-metal hydride batteries, lead-acid batteries, and various other types of battery models.	ALL	/	/	/
Initial SOC	%	Initial SOC of the single cell battery.	ALL	0.01	100.000	0.00~100.00
Initial Capacity	Ah	Initial capacity of the single cell battery.	ALL	0.01	5.00	0.00~999999.00
Initial Temperature	°C	Initial temperature of the single cell battery.	ALL	0.01	25.00	-55.00~85.00
Number of Series	/	Number of single cells in series in the battery pack.	ALL	1	1	1~9999999
Internal Resistance	mΩ	Equivalent impedance of the single cell battery.	ALL	0.01	53.00	0.00~999999.00
Capacity	AH	Single cell capacity.	ALL	0.01	5.00	0.00~999999.00

Parameters	Unit	Explanation and Application	Model	Resolution	Initial Value	Setting Range
Cable impedance	mΩ	Equivalent impedance of the battery pack's cable.	ALL	0.01	0.00	0.00~999999.00
Parallel Number	/	Number of single cells in parallel in the battery pack.	ALL	1	1	1~9999999

The battery pack containing single cell parameters includes initial capacity, capacity, SOC0% voltage, SOC100% voltage, internal resistance, etc. See the battery pack interface Figure 215, the battery pack parameters cannot be customized. See the explanation of battery pack parameter functions Table 32.



Figure 215 Single cell parameters Battery Pack Interface Diagram

Table 32 Single cell parameters battery pack parameters Function Table

Parameters	Explanation
Initial Capacity [AH]	Initial SOC of the battery pack.
Capacity [AH]	Initial capacity of the battery pack.
SOC0% Voltage [V]	Open-circuit voltage of the battery pack when SOC is 0%.
SOC 100% Voltage [V]	Open-circuit voltage of the battery pack when SOC is 100%.
Internal Resistance [$m\Omega$]	Equivalent impedance of the battery pack.

7.5.3 Settings

BatSim model settings include pre-charge time, start delay time, charge/discharge efficiency, measurement period, and temperature enable. See the settings interface Figure 216. Settings Parameter Function Explanation see Table 33.

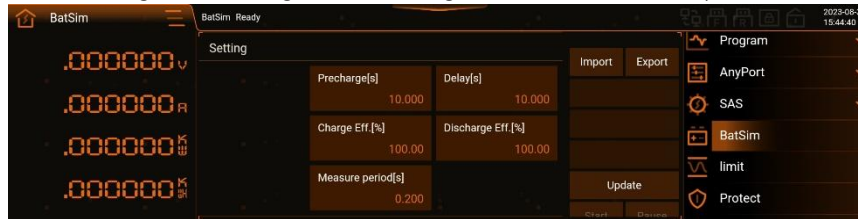

Figure 216 BatSim Settings Interface Figure

Table 33 Settings Parameter Function Table

Parameters	Unit	Explanation and Application	Model	Resolution	Initial Value	Setting Range
Pre-charge	s	Time for the output voltage to soft-start to the open-circuit voltage after pressing the output button.	ALL	0.001	0.000	0.001~9999.999
Start Delay	s	Time when the experimental delay starts.	ALL	0.001	0.000	0.001~9999.999
Charging Efficiency	%	Conversion efficiency of battery charging energy.	ALL	0.01	100.00	0.00~100.00
Discharge efficiency	%	Loss efficiency of battery discharge energy.	ALL	0.01	100.00	0.00~100.00
Measurement cycle	s	Interval time for virtual terminal to print battery log data.	ALL	0.001	0.200	0.010~10.000
Temperature enable	/	Enable/disable the impact of temperature on the battery model.	ALL	/	Disable	/

7.5.4 Cycle

The BatSim model cycle function includes cycle testing, number of cycles, cutoff SOC, cutoff capacity, cycle function interface sees Figure 217. Explanation of cycle parameter functions see Table 34.



Figure 217BatSim cycle interface figure

Table 34 cycle parameter function table

Parameters	Unit	Explanation and Application	Model	Resolution	Initial Value	Setting Range
Cycle test	/	Enable/disable cycle test function.	ALL	/	/	/
Number of cycles	/	Record the number of battery charge and discharge cycles.	ALL	1	1	1~9999999
Cut-off SOC	%	End condition for a single cycle (SOC).	ALL	0.01	50	0~100
Cut-off capacity	Ah	End condition for a single cycle (capacity).	ALL	0.000001	2.5	0~999999

7.5.5 BatSim Alarm

The BatSim model alarm function includes charge SOC, discharge SOC, charge voltage, discharge voltage. See the alarm function interface Figure 218. For the explanation of alarm parameters, see Table 35. After the user enables the alarm function, this product will provide alarm prompts based on the set parameters such as charge SOC, charge voltage, etc.



Figure 218 BatSim Alarm Interface Figure

Table 35 Alarm Parameter Function Table

Parameters	Unit	Explanation and Application	Model	Resolution	Initial Value	Setting Range
Alarm	/	Enable/Disable the experimental alarm function.	ALL	/	/	/
Charging SOC	%	SOC alarm threshold for individual cells during charging.	ALL	0.01	100.00	0.00~100.00
Discharging SOC	%	SOC alarm threshold for individual cells during discharging.	ALL	0.01	0.00	0.00~100.00
Charging Voltage	V	Alarm threshold for individual cell voltage during charging.	ALL	0.01	110% of the rated voltage	0.00~ 110% of the rated voltage
Discharging Voltage	V	Alarm threshold for individual cell voltage during discharging.	ALL	0.01	0.00	0.00~ 110% of the rated voltage

The alarm function's battery pack includes Charging SOC, Discharging SOC, Charging Voltage, Discharging Voltage, see the battery pack interface Figure 219. Battery pack parameters cannot be customized. For the explanation of battery pack parameter functions, see Table 36.



Figure 219 Alarm Battery Pack Interface Figure

Table 36 Alarm Battery Pack Parameters Function Table

Parameters	Explanation and Application
Charging SOC	Battery Pack SOC Alarm Threshold During Charging.
Charging Voltage	Battery Pack Voltage Alarm Threshold During Charging.
Discharging SOC	Battery Pack SOC Alarm Threshold During Discharging
Discharging Voltage	Battery Pack Voltage Alarm Threshold During Discharging.

7.5.6 BatSim Protection

BatSim Model Protection Functions Include Charging SOC, Discharging SOC, Charging Voltage, Discharging Voltage, Fuse Current, see Protection Function Interface Figure 220. See Protection Parameters Function Explanation Table 37.

After the user enables the Protection function, this product will stop device operation according to the set parameters such as Charging Voltage and Fuse Current.



Figure 220 BatSim Protection Interface Diagram

Table 37 Protection Parameters Function Table

Parameters	Unit	Explanation and Application	Model	Resolution	Initial Value	Setting Range
Protection	/	Enable/Disable Experimental Protection Function.	ALL	/	/	/
Charging SOC	%	SOC Protection Threshold for Single Cell During Charging.	ALL	0.01	100	0~100
Discharging SOC	%	SOC Protection Threshold for Single Cell During Discharging.	ALL	0.01	0	0~100
Charging Voltage	V	Single Cell Voltage Protection Threshold During Charging.	ALL	0.01	Rated Voltage*110%	0~ Rated Voltage*110%
Discharging Voltage	V	Single Cell Voltage Protection Threshold During Discharging.	ALL	0.01	0	0~ Rated Voltage*110%
Fuse Current	A	Charging or Discharging Current Protection Threshold.	ALL	0.01	Rated Current*110%	0~ Rated Current*110%

The protection functions include battery pack charging SOC, discharging SOC, charging voltage, discharging voltage. See the battery pack interface Figure 221. For the explanation of battery pack parameters, see Table 38.



Figure 221 Battery Pack Protection Interface Figure

Table 38 Battery Pack Protection Parameters Function Table

Parameters	Explanation and Application
Charging SOC	SOC protection threshold for battery packs during charging.
Charging Voltage	Voltage protection threshold for battery packs during charging.
Discharging SOC	SOC protection threshold for battery pack during discharging.
Discharging Voltage	Voltage protection threshold for battery packs during discharging.

BatSim Function Example:

Below, using a certain ternary lithium battery pack as an example, we introduce the usage method of the CD-B battery simulation function:

1. Battery Parameters

A certain battery pack contains 5180 lithium cells, with every 74 cells connected in parallel. See individual cell parameters Table 39.

Table 39 Single Cell Specifications Parameters Table

Serial Number	Parameters	Specifications
1	Capacity	2.8AH
2	Internal Resistance	40mΩ
3	Charge Cut-off Voltage	4.15V
4	Discharge Cut-off Voltage	2.7V

2. Test Conditions

Test Battery Charging SOC from 0%→100%, Cycle 10 times.

3. Mode Settings

Click the menu bar on the main interface - Mode, select BatSim mode.

4. Single Cell Parameter Settings

1) **Set single cell parameters:** Set single parameters according to the battery pack parameters, see Table 40.

Table 40 Single Cell Specifications Settings Parameters Table

Parameter Item	Set Value	Parameter Item	Set Value
Battery Technology	Ternary Lithium	Capacity [AH]	2.8
Initial SOC[%]	0	Number of Series	70
Internal Resistance[mΩ]	40	Number of Parallel Connections	74
Initial Temperature [°C]	25	Cable Impedance [mΩ]	0

Note: When setting the internal resistance, it is important to ensure that the battery pack's internal resistance * charge/discharge current is less than the current SOC voltage of the battery pack. The internal resistance can be reduced by increasing the number of parallel connections.



Figure 222 Single Cell Setting Interface Diagram

Update Battery Pack Parameters: After completing the single cell parameter settings, click “Update”, and the interface will display a message indicating that the data update was successful, completing the battery pack parameter update. Click on the battery pack to view and confirm the battery pack parameters, see Figure 223. After each parameter modification, the user needs to

update the battery pack parameters.



Figure 223 Battery Pack Parameter Interface Diagram

5. Charging Parameter Settings

- 1) Users can set the charging delay time, battery conversion efficiency, and other parameters according to their needs to simulate the battery's state. In this example, the parameters are set to default values, see Figure 224.
- 2) The measurement cycle is the interval time for recording battery log data on the CD-B virtual terminal. This function is used to remotely record battery measurement data on the CD-B virtual terminal, and log files in '.csv' format can be manually exported from the virtual terminal interface.

Table 41 Set Parameters Table

Parameter Item	Set Value	Parameter Item	Set Value
Pre-charge [s]	0	Start Delay [s]	0
Charging Efficiency [%]	100	Measurement Cycle [s]	0.2
Discharge Efficiency [%]	100	Temperature enables	Disable

Note: At any time during the operation in Bat Sim mode, the user can click 'Exit' to end the current test or click 'Pause' to interrupt the test.



Figure 224 Set Parameters Interface Diagram

6. Cycle Parameter Settings

- 1) **Enable Cycle Function:** Scroll down the interface to the cycle function and enable the cycle test switch.
- 2) **Set loop test parameters:** Users set loop test parameters according to requirements. For parameter settings, see Table 42, the interface is as Figure 225.
- 3) **End of loop:** After the loop ends, the interface status bar will show alarm status C YCL to indicate that the loop test is complete. This status can be reset in standby mode by briefly pressing the power button.

Table 42 Loop Test Parameters Table

Parameter Item	Set Value	Parameter Item	Set Value
Number of cycles	10	Cut-off SOC [%]	100
Cut-off Capacity [Ah]	207.2	/	/

Note: The SOC and cut-off capacity are the end conditions for each charge and discharge cycle. By default, the cycle ends when either condition is met.



Figure 225 Loop Test Parameters Interface Diagram

7. Alarm Parameter Settings

- 1) The alarm function is used to monitor the battery pack's SOC and voltage during charging and discharging and provide a prompt in case of anomalies.
- 2) When charging SOC or charging voltage exceeds the alarm set value, yellow characters OSOC and OVOL will be displayed in the interface status bar. When the discharging SOC or discharging voltage is below the alarm set value, yellow characters LSOC and LVOL will be displayed in the interface status bar. The above alarm status can be reset in standby mode by briefly pressing the power button.
- 3) Users can set according to their needs, see the example alarm parameter settings in this instance Table 43, see the OSOC alarm status display below Figure 226.

Table 43BatSim Alarm Parameter Settings Table

Parameter Item	Set Value	Parameter Item	Set Value
Charge SOC[%]	100	Discharge SOC[%]	50
Charge Voltage[V]	3.7	Discharge Voltage[V]	3

Note: The charge/discharge voltage refers to the voltage of a single cell, and the actual battery pack voltage needs to be calculated according to the series and parallel configuration of the cells.



Figure 226 Alarm Parameter Setting Interface Diagram

8. Protection Parameter Settings

- 1) The protection function is used to monitor the battery pack SOC and voltage during charging and discharging, and to provide protection in case of anomalies.
- 2) When the charge SOC or charge voltage exceeds the protection set values, red characters OSOC and OVOL will appear in the interface status bar. When the discharge SOC or discharge voltage is below the alarm set values, the status bar displays LSOC and LVOL. When the charging or discharging current exceeds the set fuse current, the status bar displays F USE. The above protection status can be reset in standby mode by briefly pressing the power button.
- 3) Users can set it according to their needs. The protection parameter settings for this example are shown in Table 44.

4) OVOL protection status display sees below Figure 227.

Table 44BatSim Protection Parameter Settings Table

Parameter Item	Set Value	Parameter Item	Set Value
Charge SOC [%]	100	Discharge SOC [%]	50
Charge Voltage[V]	4	Discharge Voltage[V]	3
Fuse Current [A]	30	/	/

Note: The charging/discharging voltage set here is for a single cell. Click on the battery pack parameters to see the actual voltage of the battery pack at the current single cell voltage.



Figure 227 Protection Parameter Settings Interface Diagram

9. Start Test

- 1) Set the DC source voltage for charging the battery to 300V, and source current to 200A, then turn on the user DC source output.
- 2) Reconfirm the battery pack parameters. After confirming they are correct, press the CD-B output button, click the start button, and the CD-B will charge according to the ternary lithium battery characteristic curve, conducting the charging cycle experiment according to the set parameters.

7.6 Mode

Click on Mode in the menu bar to enter the mode setting interface as shown Figure 228. In the mode setting interface, you can select CD-B to operate in Source Load, SAS, and BatSim modes.



Figure 228 Mode Setting Interface Diagram

For the specific functions of the SAS mode, see section 7.4, and for the specific functions of the Batsim mode, see section 7.5.

7.7 Parameters

Click on Parameters in the menu bar to enter the parameter setting interface as shown Figure 229. The parameter setting interface includes related parameter settings and function configurations for product output.

The related parameter settings for product output include voltage/current/power rise and fall times, connection delay and disconnection delay, you can also set response speed, voltage slew rate, and current slew rate.

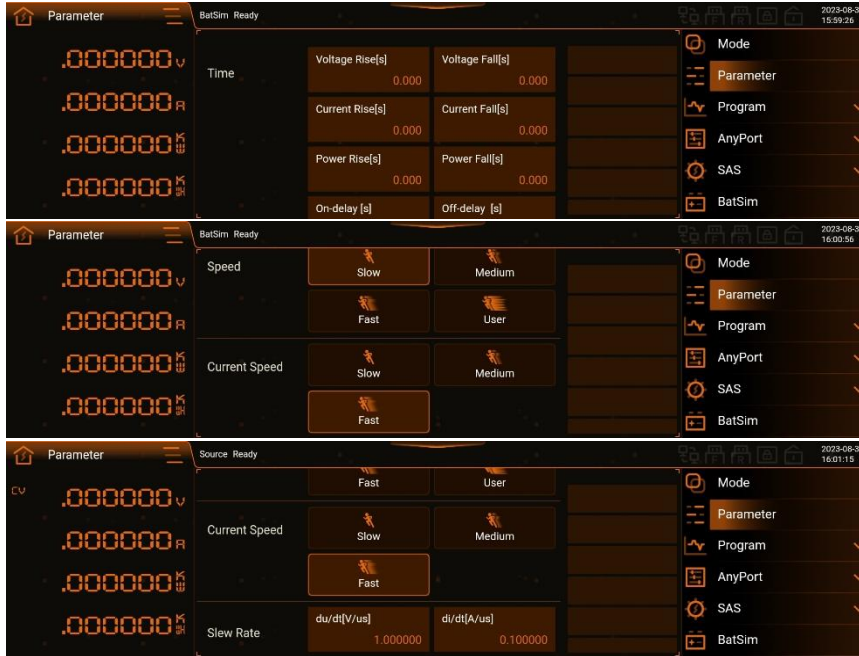

Figure 229 Parameter Setting Interface Diagram

For detailed functions of each parameter, see Table 45 .

Table 45 Alarm Enable Parameter Function Table

Parameter Item	Unit	Explanation and Application	Model	Resolution	Initial Value	Setting Range
Voltage Rise	s	The time for the output voltage to rise from the given value to the target value. When the output terminal voltage rises too quickly or too slowly, the user can control the output terminal voltage rise slope by setting this item.	ALL	0.001	0	0~999.999
Voltage Fall	s	The time for the output voltage to fall from the given value to the target value. When the output terminal voltage falls too quickly or too slowly, the user can control the output terminal voltage fall slope by setting this item.	ALL	0.001	0	0~999.999
Current Rise	s	The time for the output current to rise from the given value to the target value. When the output terminal current rises too quickly or too slowly, the user can control the output terminal current rise slope by setting this item.	ALL	0.001	0	0~999.999
Current Drop	s	The time for the output current to drop from a given value to the target value. When the current output drops too quickly or too slowly, the user can control the output current drop rate by setting this item.	ALL	0.001	0	0~999.999

Parameter Item	Unit	Explanation and Application	Model	Resolution	Initial Value	Setting Range
Power Rise	s	The time for the output power to rise from a given value to the target value. When the output power rises too quickly or too slowly, the user can control the output power rise rate by setting this item.	ALL	0.001	0	0~999.999
Power Drop	s	The time for the output power to drop from a given value to the target value. When the output power drops too quickly or too slowly, the user can control the output power drop rate by setting this item.	ALL	0.001	0	0~999.999
Turn-on Delay	s	The time from pressing the output button to the activation of the output terminal. If the user needs to delay the activation of the output terminal by a certain period, they can control the activation time by setting the turn-on delay. See the output turn-on timing diagram. Figure 136.	ALL	0.001	0	0~999.999
Turn-off Delay	s	The time from pressing the output button to the deactivation of the output terminal. If the user needs to delay the deactivation of the output terminal by a certain period, they can control the deactivation time by setting the turn-off delay. See the output turn-off timing diagram. Figure 137.	ALL	0.001	0	0~999.999
Response Speed	/	The response bandwidth of the system. When the output terminal voltage oscillates,	ALL	/	Medium Speed	Slow/Medium/Fast/User

Parameter Item	Unit	Explanation and Application	Model	Resolution	Initial Value	Setting Range
		the user can select different response speeds to adapt to their equipment.				
Voltage Slew Rate	V/ μ s	The maximum slew rate that the product can control is the voltage rise per μ s. When the output voltage slope needs adjustment, it can be controlled by setting the voltage slew rate.	ALL	0.000001	1	0.000001~10.00000
Current Slew Rate	A/ μ s	The maximum slew rate that the product can control is the current rise per μ s. When the current output slope needs adjustment, it can be controlled by setting the current slew rate.	ALL	0.000001	0.1	0.000001~1.000000

7.8 Limit Value

The limit value setting function can restrict the input range of the output setting area, effectively preventing losses caused by user mis operation and protecting user equipment. It is recommended to perform reasonable limit value settings before use. See the limit value setting interface at Figure 230, Limit Parameter Introduction See Table 46.

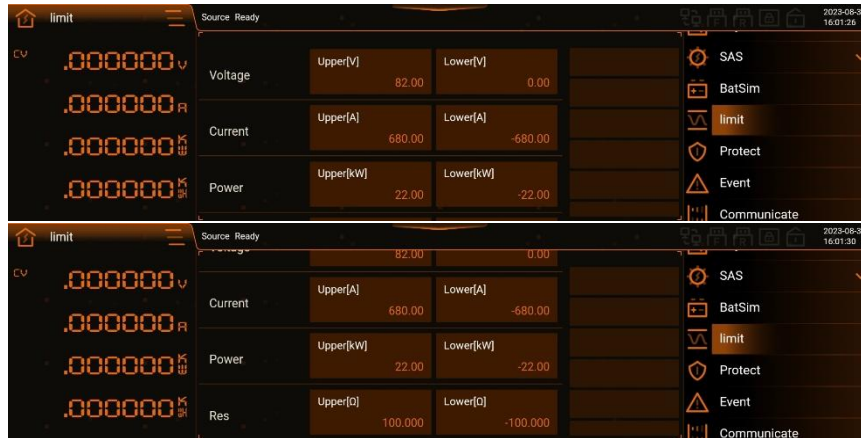

Figure 230 Limit Value Interface Figure

Table 46 Limit Function Table

Parameters	Unit	Explanation and Application	Model	Resolution	Initial Value	Setting Range
Voltage Upper Limit	V	In the output setting area, the maximum voltage can be set. To prevent damage to the equipment due to excessive voltage at the output terminal caused by erroneous operation, the user can set the voltage upper limit within a safe range here.	CD30-1K5B	0.01	1550	0.00~1550
			CD30-2K0B	0.01	2050	0.00~2050
			CD20-1K5B	0.01	1550	0.00~1550
			CD20-2K0B	0.01	2050	0.00~2050
			CD15-1K5B	0.01	1550	0.00~1550
			CD15-2K0B	0.01	2050	0.00~2050
			CD30-1K5A	0.01	1550	0.00~1550
			CD30-2K0A	0.01	2050	0.00~2050

Parameters	Unit	Explanation and Application	Model	Resolution	Initial Value	Setting Range
Voltage Upper Limit	V	In the output setting area, the maximum voltage can be set. To prevent damage to the equipment due to excessive voltage at the output terminal caused by erroneous operation, the user can set the voltage upper limit within a safe range here	CD20-1K5A	0.01	1550	0.00~1550
			CD20-2K0A	0.01	2050	0.00~2050
			CD30-800B	0.01	820	0.00~820
			CD30-1K0B	0.01	1020	0.00~1020
			CD15-1K5A	0.01	1550	0.00~1550
			CD15-2K0A	0.01	2050	0.00~2050
			CD20-800B	0.01	820	0.00~820
			CD20-1K0B	0.01	1020	0.00~1020
			CD15-800B	0.01	820	0.00~820
			CD15-1K0B	0.01	1020	0.00~1020
			CD30-800A	0.01	820	0.00~820
			CD30-1K0A	0.01	1020	0.00~1020
			CD20-800A	0.01	820	0.00~820
			CD20-1K0A	0.01	1020	0.00~1020
			CD15-800A	0.01	820	0.00~820
			CD15-1K0A	0.01	1020	0.00~1020
			CD20-040B	0.01	42	0.00~42
			CD20-040A	0.01	42	0.00~42

			CD20-060B	0.01	62	0.00~62
			CD20-060A	0.01	62	0.00~62
Voltage Upper Limit	V	In the output setting area, the maximum voltage can be set. To prevent damage to the equipment due to excessive voltage at the output terminal caused by erroneous operation, the user can set the voltage upper limit within a safe range here	CD20-080B	0.01	82	0.00~82
			CD20-080A	0.01	82	0.00~82
			CD15-040B	0.01	42	0.00~42
			CD15-040A	0.01	42	0.00~42
			CD15-060B	0.01	62	0.00~62
			CD15-060A	0.01	62	0.00~62
			CD15-080B	0.01	82	0.00~82
			CD15-080A	0.01	82	0.00~82

Parameters	Unit	Explanation and Application	Model	Resolution	Initial Value	Setting Range
Voltage Lower Limit	V	In the output setting area, the minimum voltage that can be set. To prevent damage to the equipment due to excessively low voltage at the output terminal caused by erroneous operation, the user can set the voltage lower limit within a safe range here.	CD30-1K5B	0.01	0	0.00~1550
			CD30-2K0B	0.01	0	0.00~2050

Parameters	Unit	Explanation and Application	Model	Resolution	Initial Value	Setting Range
Voltage Lower Limit	V	In the output setting area, the minimum voltage that can be set. To prevent damage to the equipment due to excessively low voltage at the output terminal caused by erroneous operation, the user can set the voltage lower limit within a safe range here.	CD20-1K5B	0.01	0	0.00~1550
			CD20-2K0B	0.01	0	0.00~2050
			CD15-1K5B	0.01	0	0.00~1550
			CD15-2K0B	0.01	0	0.00~2050
Voltage Lower Limit	V	In the output setting area, the minimum voltage that can be set. To prevent damage to the equipment due to excessively low voltage at the output terminal caused by erroneous operation, the user can set the voltage lower limit within a safe range here.	CD30-1K5A	0.01	0	0.00~1550
			CD30-2K0A	0.01	0	0.00~2050
Voltage Lower Limit	V	In the output setting area, the minimum voltage that can be set. To prevent damage to the equipment due to excessively low voltage at the output terminal caused by erroneous operation, the user can set the voltage lower limit within a safe range here.	CD20-1K5A	0.01	0	0.00~1550
			CD20-2K0A	0.01	0	0.00~2050
			CD15-1K5A	0.01	0	0.00~1550
			CD15-2K0A	0.01	0	0.00~2050
Voltage Lower Limit	V	In the output setting area, the minimum voltage that can be set. To prevent damage to the equipment due to excessively low voltage at the output terminal caused by erroneous operation, the user can set the voltage lower limit within a safe range here.	CD30-800B	0.01	0	0.00~820
			CD30-1K0B	0.01	0	0.00~1020
	V	In the output setting area, the minimum voltage that can be set. To prevent damage to the equipment due to	CD20-800B	0.01	0	0.00~820
			CD20-1K0B	0.01	0	0.00~1020

Parameters	Unit	Explanation and Application	Model	Resolution	Initial Value	Setting Range
Voltage Lower Limit		excessively low voltage at the output terminal caused by erroneous operation, the user can set the voltage lower limit within a safe range here.	CD15-800B	0.01	0	0.00~820
			CD15-1K0B	0.01	0	0.00~1020
Voltage Lower Limit	V	In the output setting area, the minimum voltage that can be set. To prevent damage to the equipment due to excessively low voltage at the output terminal caused by erroneous operation, the user can set the voltage lower limit within a safe range here.	CD30-800A	0.01	0	0.00~820
			CD30-1K0A	0.01	0	0.00~1020
			CD20-800A	0.01	0	0.00~820
			CD20-1K0A	0.01	0	0.00~1020
			CD15-800A	0.01	0	0.00~820
			CD15-1K0A	0.01	0	0.00~1020
Voltage Lower Limit	V	In the output setting area, the minimum voltage that can be set. To prevent damage to the equipment due to excessively low voltage at the output terminal caused by erroneous operation, the user can set the voltage lower limit within a safe range here.	CD20-040B	0.01	0	0.00~42
			CD20-040A	0.01	0	0.00~42
			CD20-060B	0.01	0	0.00~62
			CD20-060A	0.01	0	0.00~62
			CD20-080B	0.01	0	0.00~82
			CD20-080A	0.01	0	0.00~82
			CD15-040B	0.01	0	0.00~42
			CD15-040A	0.01	0	0.00~42
			CD15-060B	0.01	0	0.00~62

Parameters	Unit	Explanation and Application	Model	Resolution	Initial Value	Setting Range
			CD15-060A	0.01	0	0.00~62
			CD15-080B	0.01	0	0.00~82
			CD15-080A	0.01	0	0.00~82
Current Upper Limit	A	In the output setting area, the maximum value of the current can be set. To prevent the source current from becoming too high and damaging the equipment due to incorrect operation, the user can set the current upper limit within a safe range here.	CD30-1K5B	0.01	60	0.00~63
			CD30-2K0B	0.01	60	0.00~63
Current Upper Limit	A	In the output setting area, the maximum value of the current can be set. To prevent the source current from becoming too high and damaging the equipment due to incorrect operation, the user can set the current upper limit within a safe range here.	CD20-1K5B	0.01	60	0.00~63
			CD20-2K0B	0.01	60	0.00~63
			CD15-1K5B	0.01	40	0.00~42
			CD15-2K0B	0.01	40	0.00~42
Current Upper Limit	A	In the output setting area, the maximum value of the current can be set. To prevent the source current from becoming too high and damaging the equipment due to incorrect operation, the user can set the current upper limit within a safe range here.	CD30-1K5A	0.01	60	0.00~63
			CD30-2K0A	0.01	60	0.00~63
Current Upper Limit	A	In the output setting area, the maximum value of the current can be set. To prevent the source current from becoming too high and damaging the equipment due to incorrect operation, the user can set the current upper limit within a safe range here.	CD20-1K5A	0.01	60	0.00~63
			CD20-2K0A	0.01	60	0.00~63
			CD15-1K5A	0.01	40	0.00~42
			CD15-2K0A	0.01	40	0.00~42

Parameters	Unit	Explanation and Application	Model	Resolution	Initial Value	Setting Range
Current Upper Limit	A	In the output setting area, the maximum value of the current can be set. To prevent the source current from becoming too high and damaging the equipment due to incorrect operation, the user can set the current upper limit within a safe range here.	CD30-800B	0.01	80	0.00~84
			CD30-1K0B	0.01	80	0.00~84
Current Upper Limit	A	In the output setting area, the maximum value of the current can be set. To prevent the source current from becoming too high and damaging the equipment due to incorrect operation, the user can set the current upper limit within a safe range here.	CD20-800B	0.01	80	0.00~84
			CD20-1K0B	0.01	80	0.00~84
			CD15-800B	0.01	50	0.00~56.7
			CD15-1K0B	0.01	50	0.00~56.7
Current Upper Limit	A	In the output setting area, the maximum value of the current can be set. To prevent the source current from becoming too high and damaging the equipment due to incorrect operation, the user can set the current upper limit within a safe range here.	CD30-800A	0.01	80	0.00~84
			CD30-1K0A	0.01	80	0.00~84
Current Upper Limit	A	In the output setting area, the maximum value of the current can be set. To prevent the source current from becoming too high and damaging the equipment due to incorrect operation, the user can set the current upper limit within a safe range here.	CD20-800A	0.01	80	0.00~84
			CD20-1K0A	0.01	80	0.00~84
			CD15-800A	0.01	50	0.00~56.7
			CD15-1K0A	0.01	50	0.00~56.7
Current Upper Limit	A	In the output setting area, the maximum value of the current can be set. To prevent the source current from becoming too high and damaging the equipment due to	CD20-040B	0.01	680	0.00~680
			CD20-040A	0.01	680	0.00~680
			CD20-060B	0.01	680	0.00~680

Parameters	Unit	Explanation and Application	Model	Resolution	Initial Value	Setting Range
		incorrect operation, the user can set the current upper limit within a safe range here.	CD20-060A	0.01	680	0.00~680
			CD20-080B	0.01	680	0.00~680
			CD20-080A	0.01	680	0.00~680
			CD15-040B	0.01	680	0.00~680
			CD15-040A	0.01	680	0.00~680
			CD15-060B	0.01	680	0.00~680
			CD15-060A	0.01	680	0.00~680
			CD15-080B	0.01	680	0.00~680
			CD15-080A	0.01	680	0.00~680

Parameters	Unit	Explanation and Application	Model	Resolution	Initial Value	Setting Range
Current Lower Limit	A	In the output setting area, the maximum value of the load current can be set. To prevent the load current from becoming too high and damaging the equipment due to incorrect operation, the user can set the current lower limit within a safe range here.	CD30-1K5B	0.01	-60	-63~0.00
			CD30-2K0B	0.01	-60	-63~0.00
Current Lower Limit	A	In the output setting area, the maximum value of the load current can be set. To prevent the load current from becoming too high and damaging the equipment due to incorrect operation, the user can set the current lower limit within a safe range here.	CD20-1K5B	0.01	-60	-63~0.00
			CD20-2K0B	0.01	-60	-63~0.00
			CD15-1K5B	0.01	-40	-42~0.00

Parameters	Unit	Explanation and Application	Model	Resolution	Initial Value	Setting Range
			CD15-2K0B	0.01	-40	-42~0.00
Current Lower Limit	A	In the output setting area, the maximum value of the load current can be set. To prevent the load current from becoming too high and damaging the equipment due to incorrect operation, the user can set the current lower limit within a safe range here.	CD30-1K5A	0.01	-6	-6.3~0.00
			CD30-2K0A	0.01	-6	-6.3~0.00
			CD20-1K5A	0.01	-6	-6.3~0.00
			CD20-2K0A	0.01	-6	-6.3~0.00
			CD15-1K5A	0.01	-4	-4.2~0.00
			CD15-2K0A	0.01	-4	-4.2~0.00
Current Lower Limit	A	In the output setting area, the maximum value of the load current can be set. To prevent the load current from becoming too high and damaging the equipment due to incorrect operation, the user can set the current lower limit within a safe range here.	CD30-800B	0.01	-80	-84~0.00
			CD30-1K0B	0.01	-80	-84~0.00
Current Lower Limit	A	In the output setting area, the maximum value of the load current can be set. To prevent the load current from becoming too high and damaging the equipment due to incorrect operation, the user can set the current lower limit within a safe range here.	CD20-800B	0.01	-80	-84~0.00
			CD20-1K0B	0.01	-80	-84~0.00
			CD15-800B	0.01	-50	-56.7~0.00
			CD15-1K0B	0.01	-50	-56.7~0.00
Current Lower Limit	A	In the output setting area, the maximum value of the load current can be set. To prevent the load current from becoming too high and damaging the equipment due to incorrect operation, the user can set the current lower limit within a safe range here.	CD30-800A	0.01	-8	-8.4~0.00
			CD30-1K0A	0.01	-8	-8.4~0.00

Parameters	Unit	Explanation and Application	Model	Resolution	Initial Value	Setting Range
Current Lower Limit	A	In the output setting area, the maximum value of the load current can be set. To prevent the load current from becoming too high and damaging the equipment due to incorrect operation, the user can set the current lower limit within a safe range here.	CD20-800A	0.01	-8	-8.4~0.00
			CD20-1K0A	0.01	-8	-8.4~0.00
			CD15-800A	0.01	-5	-5.67~0.00
			CD15-1K0A	0.01	-5	-5.67~0.00
Current Lower Limit	A	In the output setting area, the maximum value of the load current can be set. To prevent the load current from becoming too high and damaging the equipment due to incorrect operation, the user can set the current lower limit within a safe range here.	CD20-040B	0.01	-680	-680~0.00
			CD20-040A	0.01	-68	-68~0.00
			CD20-060B	0.01	-680	-680~0.00
			CD20-060A	0.01	-68	-68~0.00
			CD20-080B	0.01	-680	-680~0.00
			CD20-080A	0.01	-68	-68~0.00
			CD15-040B	0.01	-680	-680~0.00
			CD15-040A	0.01	-68	-68~0.00
			CD15-060B	0.01	-680	-680~0.00
			CD15-060A	0.01	-68	-68~0.00
			CD15-080B	0.01	-680	-680~0.00
CD15-080A	0.01	-68	-68~0.00			

Parameters	Unit	Explanation and Application	Model	Resolution	Initial Value	Setting Range
Power Upper Limit	KW	In the output setting area, the maximum value of the source power can be set. To prevent the source power from becoming too high and damaging the equipment due to incorrect operation, the user can set the power upper limit within a safe range here.	CD30-1K5B	0.01	30	0.00~30
			CD30-2K0B	0.01	30	0.00~30
Power Upper Limit	KW	In the output setting area, the maximum value of the source power can be set. To prevent the source power from becoming too high and damaging the equipment due to incorrect operation, the user can set the power upper limit within a safe range here.	CD20-1K5B	0.01	20	0.00~20
			CD20-2K0B	0.01	20	0.00~20
			CD15-1K5B	0.01	15	0.00~15
			CD15-2K0B	0.01	15	0.00~15
Power Upper Limit	KW	In the output setting area, the maximum value of the source power can be set. To prevent the source power from becoming too high and damaging the equipment due to incorrect operation, the user can set the power upper limit within a safe range here.	CD30-1K5A	0.01	30	0.00~30
			CD30-2K0A	0.01	30	0.00~30
Power Upper Limit	KW	In the output setting area, the maximum value of the source power can be set. To prevent the source power from becoming too high and damaging the equipment due to incorrect operation, the user can set the power upper limit within a safe range here.	CD20-1K5A	0.01	20	0.00~20
			CD20-2K0A	0.01	20	0.00~20
			CD15-1K5A	0.01	15	0.00~15
			CD15-2K0A	0.01	15	0.00~15
Power Upper Limit	KW	In the output setting area, the maximum value of the source power can be set. To prevent the source power from becoming too high and damaging the equipment due to incorrect	CD30-800B	0.01	30	0.00~30
			CD30-1K0B	0.01	30	0.00~30

Parameters	Unit	Explanation and Application	Model	Resolution	Initial Value	Setting Range
		operation, the user can set the power upper limit within a safe range here.				

Parameters	Unit	Explanation and Application	Model	Resolution	Initial Value	Setting Range
Power Upper Limit	KW	In the output setting area, the maximum value of the source power can be set. To prevent the source power from becoming too high and damaging the equipment due to incorrect operation, the user can set the power upper limit within a safe range here.	CD20-800B	0.01	20	0.00~20
			CD20-1K0B	0.01	20	0.00~20
			CD15-800B	0.01	15	0.00~15
			CD15-1K0B	0.01	15	0.00~15
Power Upper Limit	KW	In the output setting area, the maximum value of the source power can be set. To prevent the source power from becoming too high and damaging the equipment due to incorrect operation, the user can set the power upper limit within a safe range here.	CD30-800A	0.01	30	0.00~30
			CD30-1K0A	0.01	30	0.00~30
Power Upper Limit	KW	In the output setting area, the maximum value of the source power can be set. To prevent the source power from becoming too high and damaging the equipment due to incorrect operation, the user can set the power upper limit within a safe range here.	CD20-800A	0.01	20	0.00~20
			CD20-1K0A	0.01	20	0.00~20
			CD15-800A	0.01	15	0.00~15
			CD15-1K0A	0.01	15	0.00~15
Power Upper Limit	KW	In the output setting area, the maximum value of the source power can be set. To prevent the source power from becoming	CD20-040B	0.01	20	0.00~20
			CD20-040A	0.01	20	0.00~20

Parameters	Unit	Explanation and Application	Model	Resolution	Initial Value	Setting Range
		too high and damaging the equipment due to incorrect operation, the user can set the power upper limit within a safe range here.	CD20-060B	0.01	20	0.00~20
			CD20-060A	0.01	20	0.00~20
			CD20-080B	0.01	20	0.00~20
			CD20-080A	0.01	20	0.00~20
			CD15-040B	0.01	15	0.00~15
			CD15-040A	0.01	15	0.00~15
			CD15-060B	0.01	15	0.00~15
			CD15-060A	0.01	15	0.00~15
			CD15-080B	0.01	15	0.00~15
			CD15-080A	0.01	15	0.00~15

Parameters	Unit	Explanation and Application	Model	Resolution	Initial Value	Setting Range
Power Lower Limit	KW	In the output setting area, the minimum value of the source power can be set. To prevent the source power from becoming too high and damaging the equipment due to incorrect operation, the user can set the power upper limit within a safe range here.	CD30-1K5B	0.01	-30	-30~0.00
			CD30-2K0B	0.01	-30	-30~0.00
Power Lower Limit	KW	In the output setting area, the minimum value of the source power can be set. To prevent the source power from becoming	CD20-1K5B	0.01	-20	-20~0.00
			CD20-2K0B	0.01	-20	-20~0.00

Parameters	Unit	Explanation and Application	Model	Resolution	Initial Value	Setting Range
		too high and damaging the equipment due to incorrect operation, the user can set the power upper limit within a safe range here.	CD15-1K5B	0.01	-15	-15~0.00
			CD15-2K0B	0.01	-15	-15~0.00
Power Lower Limit	KW	In the output setting area, the minimum value of the source power can be set. To prevent the source power from becoming too high and damaging the equipment due to incorrect operation, the user can set the power upper limit within a safe range here.	CD30-1K5A	0.01	-3	-3~0.00
			CD30-2K0A	0.01	-3	-3~0.00
Power Lower Limit	KW	In the output setting area, the minimum value of the source power can be set. To prevent the source power from becoming too high and damaging the equipment due to incorrect operation, the user can set the power upper limit within a safe range here.	CD20-1K5A	0.01	-2	-2~0.00
			CD20-2K0A	0.01	-2	-2~0.00
			CD15-1K5A	0.01	-1.5	-1.5~0.00
			CD15-2K0A	0.01	-1.5	-1.5~0.00
Power Lower Limit	KW	In the output setting area, the minimum value of the source power can be set. To prevent the source power from becoming too high and damaging the equipment due to incorrect operation, the user can set the power upper limit within a safe range here.	CD30-800B	0.01	-30	-30~0.00
			CD30-1K0B	0.01	-30	-30~0.00

Parameters	Unit	Explanation and Application	Model	Resolution	Initial Value	Setting Range
Power Lower Limit	KW	In the output setting area, the minimum value of the source power can be set. To prevent the source power from becoming	CD20-800B	0.01	-20	-20~0.00
			CD20-1K0B	0.01	-20	-20~0.00

Parameters	Unit	Explanation and Application	Model	Resolution	Initial Value	Setting Range
		too high and damaging the equipment due to incorrect operation, the user can set the power upper limit within a safe range here.	CD15-800B	0.01	-15	-15~0.00
			CD15-1K0B	0.01	-15	-15~0.00
Power Lower Limit	KW	In the output setting area, the minimum value of the source power can be set. To prevent the source power from becoming too high and damaging the equipment due to incorrect operation, the user can set the power upper limit within a safe range here.	CD30-800A	0.01	-3	-3~0.00
			CD30-1K0A	0.01	-3	-3~0.00
Power Lower Limit	KW	In the output setting area, the minimum value of the source power can be set. To prevent the source power from becoming too high and damaging the equipment due to incorrect operation, the user can set the power upper limit within a safe range here.	CD20-800A	0.01	-2	-2~0.00
			CD20-1K0A	0.01	-2	-2~0.00
			CD15-800A	0.01	-1.5	-1.5~0.00
			CD15-1K0A	0.01	-1.5	-1.5~0.00
Power Lower Limit	KW	In the output setting area, the minimum value of the source power can be set. To prevent the source power from becoming too high and damaging the equipment due to incorrect operation, the user can set the power upper limit within a safe range here.	CD20-040B	0.01	-20	-20~0.00
			CD20-040A	0.01	-2	-2~0.00
			CD20-060B	0.01	-20	-20~0.00
			CD20-060A	0.01	-2	-2~0.00
			CD20-080B	0.01	-20	-20~0.00
			CD20-080A	0.01	-2	-2~0.00
			CD15-040B	0.01	-15	-15~0.00
			CD15-040A	0.01	-1.5	-1.5~0.00

Parameters	Unit	Explanation and Application	Model	Resolution	Initial Value	Setting Range
			CD15-060B	0.01	-15	-15~0.00
			CD15-060A	0.01	-1.5	-1.5~0.00
			CD15-080B	0.01	-15	-15~0.00
			CD15-080A	0.01	-1.5	-1.5~0.00

Parameters	Unit	Explanation and Application	Model	Resolution	Initial Value	Setting Range
Upper Limit of Internal Resistance	Ω	The maximum value of the source internal resistance that can be set in the output setting area. To prevent damage to the equipment due to excessive internal resistance caused by misoperation, users can set the upper limit of internal resistance within a safe range here.	CD30-1K5B	0.01	3000	0.5~3000
			CD30-2K0B	0.01	3000	0.5~3000
			CD20-1K5B	0.01	3000	0.5~3000
			CD20-2K0B	0.01	3000	0.5~3000
			CD15-1K5B	0.01	3000	0.5~3000
			CD15-2K0B	0.01	3000	0.5~3000
			CD30-1K5A	0.01	3000	0.5~3000
			CD30-2K0A	0.01	3000	0.5~3000
			CD20-1K5A	0.01	3000	0.5~3000
			CD20-2K0A	0.01	3000	0.5~3000
			CD15-1K5A	0.01	3000	0.5~3000

Parameters	Unit	Explanation and Application	Model	Resolution	Initial Value	Setting Range
			CD15-2K0A	0.01	3000	0.5~3000
			CD30-800B	0.01	100	0.05~100
			CD30-1K0B	0.01	100	0.05~100
			CD20-800B	0.01	100	0.05~100
			CD20-1K0B	0.01	100	0.05~100
			CD15-800B	0.01	100	0.05~100
			CD15-1K0B	0.01	100	0.05~100
			CD30-800A	0.01	100	0.05~100
			CD30-1K0A	0.01	100	0.05~100
			CD20-800A	0.01	100	0.05~100
			CD20-1K0A	0.01	100	0.05~100
			CD15-800A	0.01	100	0.05~100
			CD15-1K0A	0.01	100	0.003~100
			CD20-040B	0.01	100	0.003~100
			CD20-060B	0.01	100	0.003~100
			CD20-060A	0.01	100	0.003~100
			CD20-080B	0.01	100	0.003~100
			CD20-080A	0.01	100	0.003~100

Parameters	Unit	Explanation and Application	Model	Resolution	Initial Value	Setting Range
			CD15-040B	0.01	100	0.003~100
			CD15-040A	0.01	100	0.003~100
			CD15-060B	0.01	100	0.003~100
			CD15-060A	0.01	100	0.003~100
			CD15-080B	0.01	100	0.003~100
			CD15-080A	0.01	100	0.003~100

Parameters	Unit	Explanation and Application	Model	Resolution	Initial Value	Setting Range
Lower Limit of Internal Resistance	Ω	The minimum value of the source internal resistance that can be set in the output setting area. To prevent damage to the equipment due to too low internal resistance caused by misoperation, users can set the lower limit of internal resistance within a safe range here.	CD30-1K5B	0.01	0.5	0.5~3000
			CD30-2K0B	0.01	0.5	0.5~3000
			CD20-1K5B	0.01	0.5	0.5~3000
			CD20-2K0B	0.01	0.5	0.5~3000
			CD15-1K5B	0.01	0.5	0.5~3000
			CD15-2K0B	0.01	0.5	0.5~3000
			CD30-1K5A	0.01	0.5	0.5~3000
			CD30-2K0A	0.01	0.5	0.5~3000
			CD20-1K5A	0.01	0.5	0.5~3000
			CD20-2K0A	0.01	0.5	0.5~3000
			CD15-1K5A	0.01	0.5	0.5~3000
			CD15-2K0A	0.01	0.5	0.5~3000
			CD30-800B	0.01	0.05	0.05~100
			CD30-1K0B	0.01	0.05	0.05~100
			CD20-800B	0.01	0.05	0.05~100
			CD20-1K0B	0.01	0.05	0.05~100
CD15-800B	0.01	0.05	0.05~100			

Parameters	Unit	Explanation and Application	Model	Resolution	Initial Value	Setting Range
			CD15-1K0B	0.01	0.05	0.05~100
			CD30-800A	0.01	0.05	0.05~100
			CD30-1K0A	0.01	0.05	0.05~100
			CD20-800A	0.01	0.05	0.05~100
			CD20-1K0A	0.01	0.05	0.05~100
			CD15-800A	0.01	0.05	0.05~100
			CD15-1K0A	0.01	0.05	0.05~100
			CD20-040B	0.01	0.003	0.003~100
			CD20-040A	0.01	0.003	0.003~100
			CD20-060B	0.01	0.003	0.003~100
			CD20-060A	0.01	0.003	0.003~100
			CD20-080B	0.01	0.003	0.003~100
			CD20-080A	0.01	0.003	0.003~100
			CD15-040B	0.01	0.003	0.003~100
			CD15-040A	0.01	0.003	0.003~100
			CD15-060B	0.01	0.003	0.003~100
			CD15-060A	0.01	0.003	0.003~100
			CD15-080B	0.01	0.003	0.003~100

Parameters	Unit	Explanation and Application	Model	Resolution	Initial Value	Setting Range
			CD15-080A	0.01	0.003	0.003~100

7.9 Protection

CD-B features dual protection for the output terminal and the remote sensing terminal. Not only can protection values for voltage, current, and power be set at the output terminal, but the upper limit of the remote sensing voltage can also be set, ensuring greater safety for user equipment and CD-B. For the protection settings interface, see Figure 231, see parameter introduction Table 47.



Figure 231 Protection Interface Diagram

Table 47 Protection Settings Parameter Table

Parameters	Unit	Explanation and Application	Model	Resolution	Initial Value	Setting Range
Telemetry Difference	V	The protection value of the difference between the remote voltage and the output port voltage. When the user needs to compensate for the voltage drop in the line, it can be done in Section 7.12. Enable remote compensation in, this product will control the remote voltage to remain consistent with the set value through the internal loop, by setting this parameter to control the maximum voltage value that can be compensated remotely, if the difference exceeds this parameter setting value, it will be protected.	CD30-1K5B	0.01	30	0.01~30
			CD30-2K0B	0.01	40	0.01~40
Telemetry Difference	V	The protection value of the difference between the remote voltage and the output port voltage. When the user needs to compensate for the voltage drop in the line, it can be done in Section 7.12, Enable remote compensation in, this product will control the remote voltage to remain consistent with the set value through the internal loop, by setting this parameter to control the maximum voltage value that can be compensated remotely, if the difference exceeds this parameter setting value, it will be protected.	CD30-1K5A	0.01	30	0.01~30
			CD30-2K0A	0.01	40	0.01~40
Telemetry Difference	V	The protection value of the difference between the remote voltage and the output port voltage. When the user needs to compensate for the voltage drop in the line, it can be done in Section 7.12. Enable remote compensation in, this product will control the remote voltage to remain consistent with the set value through the internal loop, by setting this parameter to control the maximum voltage value that can be compensated	CD30-800B	0.01	16	0.01~16
			CD30-1K0B	0.01	20	0.01~20

Parameters	Unit	Explanation and Application	Model	Resolution	Initial Value	Setting Range
		remotely, if the difference exceeds this parameter setting value, it will be protected.				
Telemetry Difference	V	The protection value of the difference between the remote voltage and the output port voltage. When the user needs to compensate for the voltage drop in the line, it can be done in Section 7.12. Enable remote compensation in, this product will control the remote voltage to remain consistent with the set value through the internal loop, by setting this parameter to control the maximum voltage value that can be compensated remotely, if the difference exceeds this parameter setting value, it will be protected.	CD30-800A	0.01	16	0.01~16
			CD30-1K0A	0.01	20	0.01~20

Parameters	Unit	Explanation and Application	Model	Resolution	Initial Value	Setting Range
Telemetry Difference	V	The protection value of the difference between the remote voltage and the output port voltage. When the user needs to compensate for the voltage drop in the line, it can be done in Section 7.12 Enable remote compensation in, this product will control the remote voltage to remain consistent with the set value through the internal loop, by setting this parameter to control the maximum voltage value that can be compensated remotely, if the difference exceeds this parameter setting value, it will be protected.	CD20-1K5B	0.01	30	0.01~30
			CD20-2K0B	0.01	40	0.01~40
			CD15-1K5B	0.01	30	0.01~30
			CD15-2K0B	0.01	40	0.01~40
Telemetry Difference	V	The protection value of the difference between the remote voltage and the output port voltage. When the user needs to compensate for the voltage drop in the line, it can be done in Section 7.12. Enable remote compensation in, this product will control the remote voltage to remain consistent with the set value through the internal loop, by setting this parameter to control the maximum voltage value that can be compensated remotely, if the difference exceeds this parameter setting value, it will be protected.	CD20-1K5A	0.01	30	0.01~30
			CD20-2K0A	0.01	40	0.01~40
			CD15-1K5A	0.01	30	0.01~30
			CD15-2K0A	0.01	40	0.01~40
Telemetry Difference	V	The protection value of the difference between the remote voltage and the output port voltage. When the user needs to compensate for the voltage drop in the line, it can be done in Section 7.12. Enable remote compensation in, this product will control the remote voltage to remain consistent with the set value through the internal loop, by setting this parameter to control the maximum voltage value that can be compensated	CD20-800B	0.01	16	0.01~16
			CD20-1K0B	0.01	20	0.01~20
			CD15-800B	0.01	16	0.01~16
			CD15-1K0B	0.01	20	0.01~20

Parameters	Unit	Explanation and Application	Model	Resolution	Initial Value	Setting Range
		remotely, if the difference exceeds this parameter setting value, it will be protected.				
Telemetry Difference	V	The protection value of the difference between the remote voltage and the output port voltage. When the user needs to compensate for the voltage drop in the line, it can be done in Section 7.12. Enable remote compensation in, this product will control the remote voltage to remain consistent with the set value through the internal loop, by setting this parameter to control the maximum voltage value that can be compensated remotely, if the difference exceeds this parameter setting value, it will be protected.	CD20-800A	0.01	16	0.01~16
			CD20-1K0A	0.01	20	0.01~20
			CD15-800A	0.01	16	0.01~16
			CD15-1K0A	0.01	20	0.01~20
Telemetry Difference	V	The protection value of the difference between the remote voltage and the output port voltage. When the user needs to compensate for the voltage drop in the line, it can be done in Section 7.12. Enable remote compensation in, this product will control the remote voltage to remain consistent with the set value through the internal loop, by setting this parameter to control the maximum voltage value that can be compensated remotely, if the difference exceeds this parameter setting value, it will be protected.	CD20-040B	0.01	40	0.01~40
			CD20-040A	0.01	40	0.01~40
			CD20-060B	0.01	60	0.01~60
			CD20-060A	0.01	60	0.01~60
			CD20-080B	0.01	80	0.01~80
			CD20-080A	0.01	80	0.01~80
			CD15-040B	0.01	40	0.01~40
			CD15-040A	0.01	40	0.01~40
			CD15-060B	0.01	60	0.01~60
CD15-060A	0.01	60	0.01~60			

Parameters	Unit	Explanation and Application	Model	Resolution	Initial Value	Setting Range
			CD15-080B	0.01	80	0.01~80
			CD15-080A	0.01	80	0.01~80
Parameters	Unit	Explanation and Application	Model	Resolution	Initial Value	Setting Range
Telemetry Upper Limit	V	Remote voltage protection value. To protect the maximum voltage of the remote end, the user can set this parameter.	CD30-1K5B	0.01	1650	0.01~1650
			CD30-2K0B	0.01	2000	0.01~2000
Telemetry Upper Limit	V	Remote voltage protection value. To protect the maximum voltage of the remote end, the user can set this parameter.	CD30-1K5A	0.01	1650	0.01~1650
			CD30-2K0A	0.01	2000	0.01~2000
			CD30-800B	0.01	880	0.01~880
			CD30-1K0B	0.01	1100	0.01~1100

Parameters	Unit	Explanation and Application	Model	Resolution	Initial Value	Setting Range
Telemetry Upper Limit	V	Remote voltage protection value. To protect the maximum voltage of the remote end, the user can set this parameter.	CD30-800A	0.01	880	0.01~880
			CD30-1K0A	0.01	1100	0.01~1100

Parameters	Unit	Explanation and Application	Model	Resolution	Initial Value	Setting Range
Telemetry Upper Limit	V	Remote voltage protection value. To protect the maximum voltage of the remote end, the user can set this parameter.	CD20-1K5B	0.01	1650	0.01~1650
			CD20-2K0B	0.01	2000	0.01~2000
			CD15-1K5B	0.01	1650	0.01~1650
			CD15-2K0B	0.01	2000	0.01~2000
Telemetry Upper Limit	V	Remote voltage protection value. To protect the maximum voltage of the remote end, the user can set this parameter.	CD20-1K5A	0.01	1650	0.01~1650
			CD20-2K0A	0.01	2000	0.01~2000
			CD15-1K5A	0.01	1650	0.01~1650
			CD15-2K0A	0.01	2000	0.01~2000
Telemetry Upper Limit	V	Remote voltage protection value. To protect the maximum voltage of the remote end, the user can set this parameter.	CD20-800B	0.01	880	0.01~880
			CD20-1K0B	0.01	1100	0.01~1100
			CD15-800B	0.01	880	0.01~880
			CD15-1K0B	0.01	1100	0.01~1100
Telemetry Upper Limit	V	Remote voltage protection value. To protect the maximum voltage of the remote end, the user can set this parameter.	CD20-800A	0.01	880	0.01~880
			CD20-1K0A	0.01	1100	0.01~1100
			CD15-800A	0.01	880	0.01~880
			CD15-1K0A	0.01	1100	0.01~1100
Telemetry Upper Limit	V	Remote voltage protection value. To protect the maximum voltage of the remote end, the user can set this parameter.	CD20-040B	0.01	44	0.01~44
			CD20-040A	0.01	44	0.01~44

Parameters	Unit	Explanation and Application	Model	Resolution	Initial Value	Setting Range
			CD20-060B	0.01	66	0.01~66
			CD20-060A	0.01	66	0.01~66
			CD20-080B	0.01	88	0.01~88
			CD20-080A	0.01	88	0.01~88
			CD15-040B	0.01	44	0.01~44
			CD15-040A	0.01	44	0.01~44
			CD15-060B	0.01	66	0.01~66
			CD15-060A	0.01	66	0.01~66
			CD15-080B	0.01	88	0.01~88
			CD15-080A	0.01	88	0.01~88

Parameters	Unit	Explanation and Application	Model	Resolution	Initial Value	Setting Range
Overvoltage Threshold	V	Overvoltage protection threshold. Users can set this parameter to protect the maximum voltage at the output terminal.	CD30-1K5B	0.01	1650	0.01~1650
			CD30-2K0B	0.01	2000	0.01~2000

Parameters	Unit	Explanation and Application	Model	Resolution	Initial Value	Setting Range
Overvoltage Threshold	V	Overvoltage protection threshold. Users can set this parameter to protect the maximum voltage at the output terminal.	CD30-1K5A	0.01	1650	0.01~1650
			CD30-2K0A	0.01	2000	0.01~2000

Parameters	Unit	Explanation and Application	Model	Resolution	Initial Value	Setting Range
Overvoltage Threshold	V	Overvoltage protection threshold. Users can set this parameter to protect the maximum voltage at the output terminal.	CD30-800B	0.01	880	0.01~880
			CD30-1K0B	0.01	1100	0.01~1100
Overvoltage Threshold	V	Overvoltage protection threshold. Users can set this parameter to protect the maximum voltage at the output terminal.	CD30-800A	0.01	880	0.01~880
			CD30-1K0A	0.01	1100	0.01~1100
Overvoltage Threshold	V	Overvoltage protection threshold. Users can set this parameter to protect the maximum voltage at the output terminal.	CD20-1K5B	0.01	1650	0.01~1650
			CD20-2K0B	0.01	2000	0.01~2000
			CD15-1K5B	0.01	1650	0.01~1650
			CD15-2K0B	0.01	2000	0.01~2000
Overvoltage Threshold	V	Overvoltage protection threshold. Users can set this parameter to protect the maximum voltage at the output terminal.	CD20-1K5A	0.01	1650	0.01~1650
			CD20-2K0A	0.01	2000	0.01~2000
			CD15-1K5A	0.01	1650	0.01~1650
			CD15-2K0A	0.01	2000	0.01~2000
Overvoltage Threshold	V	Overvoltage protection threshold. Users can set this parameter to protect the maximum voltage at the output terminal.	CD20-800B	0.01	880	0.01~880
			CD20-1K0B	0.01	1100	0.01~1100
			CD15-800B	0.01	880	0.01~880
			CD15-1K0B	0.01	1100	0.01~1100
	V		CD20-800A	0.01	880	0.01~880

Parameters	Unit	Explanation and Application	Model	Resolution	Initial Value	Setting Range
Overvoltage Threshold		Overvoltage protection threshold. Users can set this parameter to protect the maximum voltage at the output terminal.	CD20-1K0A	0.01	1100	0.01~1100
			CD15-800A	0.01	880	0.01~880
			CD15-1K0A	0.01	1100	0.01~1100
Overvoltage Threshold	V	Overvoltage protection threshold. Users can set this parameter to protect the maximum voltage at the output terminal.	CD20-040B	0.01	44	0.01~44
			CD20-040A	0.01	44	0.01~44
			CD20-060B	0.01	66	0.01~66
			CD20-060A	0.01	66	0.01~66
			CD20-080B	0.01	88	0.01~88
			CD20-080A	0.01	88	0.01~88
			CD15-040B	0.01	44	0.01~44
			CD15-040A	0.01	44	0.01~44
			CD15-060B	0.01	66	0.01~66
			CD15-060A	0.01	66	0.01~66
			CD15-080B	0.01	88	0.01~88
			CD15-080A	0.01	88	0.01~88

Parameters	Unit	Explanation and Application	Model	Resolution	Initial Value	Setting Range
Overcurrent Threshold	A	Overcurrent protection threshold. Users can set this parameter to protect the maximum current at the output terminal.	CD30-1K5B	0.01	66	0.01~66
			CD30-2K0B	0.01	66	0.01~66
Overcurrent Threshold	A	Overcurrent protection threshold. Users can set this parameter to protect the maximum current at the output terminal.	CD30-1K5A	0.01	66	0.01~66
			CD30-2K0A	0.01	66	0.01~66
Overcurrent Threshold	A	Overcurrent protection threshold. Users can set this parameter to protect the maximum current at the output terminal.	CD30-800B	0.01	88	0.01~88
			CD30-1K0B	0.01	88	0.01~88
Overcurrent Threshold	A	Overcurrent protection threshold. Users can set this parameter to protect the maximum current at the output terminal.	CD30-800A	0.01	88	0.01~88
			CD30-1K0A	0.01	88	0.01~88
Overcurrent Threshold	A	Overcurrent protection threshold. Users can set this parameter to protect the maximum current at the output terminal.	CD20-1K5B	0.01	66	0.01~66
			CD20-2K0B	0.01	66	0.01~66
			CD15-1K5B	0.01	44	0.01~44
			CD15-2K0B	0.01	44	0.01~44
Overcurrent Threshold	A	Overcurrent protection threshold. Users can set this parameter to protect the maximum current at the output terminal.	CD20-1K5A	0.01	66	0.01~66
			CD20-2K0A	0.01	66	0.01~66
			CD15-1K5A	0.01	44	0.01~44
			CD15-2K0A	0.01	44	0.01~44
Overcurrent Threshold	A	Overcurrent protection threshold. Users can set this parameter to protect the maximum current at the output terminal.	CD20-800B	0.01	88	0.01~88
			CD20-1K0B	0.01	88	0.01~88

Parameters	Unit	Explanation and Application	Model	Resolution	Initial Value	Setting Range
			CD15-800B	0.01	59.4	0.01~59.4
			CD15-1K0B	0.01	59.4	0.01~59.4
Overcurrent Threshold	A	Overcurrent protection threshold. Users can set this parameter to protect the maximum current at the output terminal.	CD20-800A	0.01	88	0.01~88
			CD20-1K0A	0.01	88	0.01~88
			CD15-800A	0.01	59.4	0.01~59.4
			CD15-1K0A	0.01	59.4	0.01~59.4
Overcurrent Threshold	A	Overcurrent protection threshold. Users can set this parameter to protect the maximum current at the output terminal.	CD20-040B	0.01	733.7	0.01~733.7
			CD20-040A	0.01	733.7	0.01~733.7
			CD20-060B	0.01	733.7	0.01~733.7
			CD20-060A	0.01	733.7	0.01~733.7
			CD20-080B	0.01	733.7	0.01~733.7
			CD20-080A	0.01	733.7	0.01~733.7
			CD15-040B	0.01	733.7	0.01~733.7
			CD15-040A	0.01	733.7	0.01~733.7
			CD15-060B	0.01	733.7	0.01~733.7
			CD15-060A	0.01	733.7	0.01~733.7
			CD15-080B	0.01	733.7	0.01~733.7
			CD15-080A	0.01	733.7	0.01~733.7

Parameters	Unit	Explanation and Application	Model	Resolution	Initial Value	Setting Range
Power Threshold	KW	Overpower protection threshold. Users can set this parameter to protect the maximum power at the output terminal.	CD30-1K5B	0.01	33	0.01~33
			CD30-2K0B	0.01	33	0.01~33
Power Threshold	KW	Overpower protection threshold. Users can set this parameter to protect the maximum power at the output terminal.	CD30-1K5A	0.01	33	0.01~33
			CD30-2K0A	0.01	33	0.01~33
Power Threshold	KW	Overpower protection threshold. Users can set this parameter to protect the maximum power at the output terminal.	CD30-800B	0.01	33	0.01~33
			CD30-1K0B	0.01	33	0.01~33

Parameters	Unit	Explanation and Application	Model	Resolution	Initial Value	Setting Range
Power Threshold	KW	Overpower protection threshold. Users can set this parameter to protect the maximum power at the output terminal.	CD30-800A	0.01	33	0.01~33
			CD30-1K0A	0.01	33	0.01~33

Parameters	Unit	Explanation and Application	Model	Resolution	Initial Value	Setting Range
Power Threshold	KW	Overpower protection threshold. Users can set this parameter to protect the maximum power at the output terminal.	CD20-1K5B	0.01	22	0.01~22
			CD20-2K0B	0.01	22	0.01~22
			CD15-1K5B	0.01	16.5	0.01~16.5
			CD15-2K0B	0.01	16.5	0.01~16.5
Power Threshold	KW	Overpower protection threshold. Users can set this parameter to protect the maximum power at the output terminal.	CD20-1K5A	0.01	22	0.01~22
			CD20-2K0A	0.01	22	0.01~22
			CD15-1K5A	0.01	16.5	0.01~16.5
			CD15-2K0A	0.01	16.5	0.01~16.5
Power Threshold	KW	Overpower protection threshold. Users can set this parameter to protect the maximum power at the output terminal.	CD20-800B	0.01	22	0.01~22
			CD20-1K0B	0.01	22	0.01~22
			CD15-800B	0.01	16.5	0.01~16.5
			CD15-1K0B	0.01	16.5	0.01~16.5
Power Threshold	KW	Overpower protection threshold. Users can set this parameter to protect the maximum power at the output terminal.	CD20-800A	0.01	22	0.01~22
			CD20-1K0A	0.01	22	0.01~22
			CD15-800A	0.01	16.5	0.01~16.5
			CD15-1K0A	0.01	16.5	0.01~16.5
Power Threshold	KW	Overpower protection threshold. Users can set this parameter to protect the maximum power at the output terminal.	CD20-040B	0.01	22	0.01~22
			CD20-040A	0.01	22	0.01~22

Parameters	Unit	Explanation and Application	Model	Resolution	Initial Value	Setting Range
			CD20-060B	0.01	22	0.01~22
			CD20-060A	0.01	22	0.01~22
			CD20-080B	0.01	22	0.01~22
			CD20-080A	0.01	22	0.01~22
			CD15-040B	0.01	16.5	0.01~16.5
			CD15-040A	0.01	16.5	0.01~16.5
			CD15-060B	0.01	16.5	0.01~16.5
			CD15-060A	0.01	16.5	0.01~16.5
			CD15-080B	0.01	16.5	0.01~16.5
			CD15-080A	0.01	16.5	0.01~16.5

Note : For the rated voltage/current/power and other parameters of this product model, please refer to the technical specifications. 3.5 技术参数.

7.10 Event

CD-B is designed with an event recording function, which can monitor specific situations that occur during operation, making it convenient for users to observe and understand the working condition of the equipment. The event setting interface is shown in Figure 232 as shown, the function is in Table 48.



Figure 232 Event Settings Interface Figure

Table 48 Settings Event Function Table

Parameters	Unit	Explanation and Application	Model	Resolution	Initial Value	Setting Range
Trigger Source	/	When the user needs to monitor the status of voltage/current/power/temperature, they can select the corresponding trigger source to trigger the event.	ALL	/	None	/
Trigger Threshold	%	Percentage of the rated value of the trigger source, with the rated value of temperature being 100°C. Users can set the trigger threshold to establish the conditions for triggering an event.	ALL	0.01	100.00	0~100
Trigger Time	s	The time for the trigger event after exceeding the trigger threshold. Users can set this parameter to control the speed of event triggering.	ALL	0.001	0	0~9999
Action Mode	/	Warning: After the warning, the product can operate normally, and "Event X" will flash in the status display area. When an event occurs, if the user only needs a warning prompt, they can select the action mode as warning.	ALL	/	Warning	/
		Alarm: After the alarm, the product will disconnect the output terminal, and 'Event X' will flash in the status display area. When an event occurs, if the user needs an alarm and disconnects the output terminal, they can select the action mode as alarm.	ALL			
		Record: When recording an event, the product can operate normally, and it is necessary to 7.13.2click Start Recording in the Log Interface section. When an event occurs, if the user only needs to log the event, they can select the action mode as record.	ALL			
Threshold Direction	/	When the voltage/ current/ power/ temperature exceeds the trigger threshold upwards, an event is triggered. If the user needs to trigger an event when exceeding the trigger threshold upwards, they need	ALL	/	Upward	/

Parameters	Unit	Explanation and Application	Model	Resolution	Initial Value	Setting Range
		to set the threshold direction to upwards. When the voltage/ current/ power/ temperature falls below the trigger threshold, an event is triggered. When the user needs to trigger an event when falling below the trigger threshold, the direction needs to be set to downward.				
Clear Event	/	Clear the current event status by number. The power/reset button also has the function to clear events. If the user needs to clear events and clear the event status in the status display area, they can press this button.	ALL	/	/	/

Event Trigger See schematic diagram Figure 233, set the trigger source to voltage, trigger threshold to 25%, rated voltage 2000V, threshold direction is upward, trigger time is 1s. In the following diagram, event 1 trigger time is less than 1s, therefore cannot trigger the event. Event 2 meets the event trigger requirements.

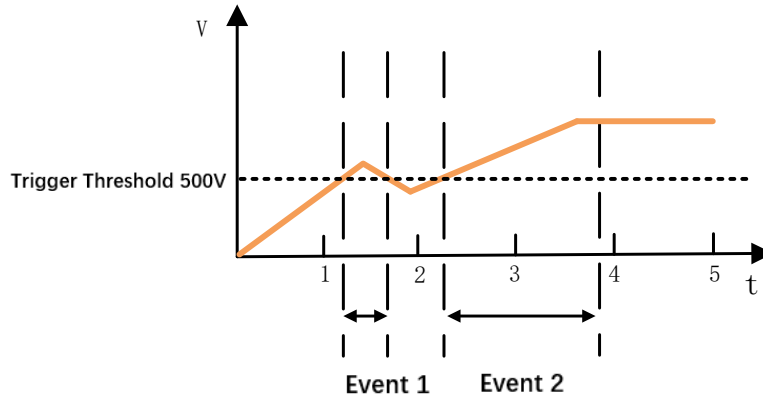

Figure 233 Event Trigger Schematic Diagram

7.11 Communication

CD-B can switch between local and remote communication modes, remote supports LAN and US B to communicate with user devices. Click on communication in the menu bar to enter the communication settings interface. In the communication settings interface, you can choose to assign control of CD-B to different ports, achieving local/remote control. See the communication settings interface Figure 234, see the explanation of each parameter in Table 49.



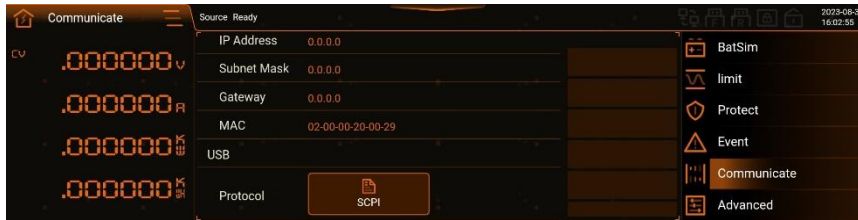

Figure 234 Communication Settings Interface Diagram

Table 49 Communication Interface Parameter Explanation Table

Parameter Item	Unit	Explanation	Model	Resolution	Initial Value	Setting Range
Local Lock	/	Lock local control authority, other ports cannot obtain control authority. The local lock can only be enabled in local control mode, and once enabled, remote communication cannot be set.	ALL	/	/	/
Device Number	/	Used to set the product address.	ALL	/	1	0~127
Communication Port	/	Select the control mode for this product. When the local lock is disabled, the remote communication port can obtain product control permissions through commands. Screen: Display screen local control. Lan: Ethernet remote control. USB: USB remote control. BUS: Magic-Bus includes 485 communication port, CAN communication port, external expansion L an port, and requires the installation of the Magic-Bus component to be enabled.	ALL	/	/	/

Parameter Item	Unit	Explanation	Model	Resolution	Initial Value	Setting Range
Communication Protocol	/	The LAN port of this product supports SCPI and Modbus-TCP communication protocols.	ALL	/	/	/
IP Assignment	/	Automatic and Manual.	ALL	/	/	/
IP Address	/	The I P address type is I P v4.	ALL	/	1	0~127
Port Number	/	The communication port number of this product.	ALL	/	502	1~65535
USB	/	The USB port supports the SCPI communication protocol.	ALL	/	/	/

7.12 Advanced

Click on Advanced in the menu bar to enter the advanced settings interface. The advanced settings interface is shown Figure 235, providing users with the ability to set trigger input/output methods, trigger delay time, start mode, negative linkage enable, communication monitoring, automatic operation, voltage zeroing, remote compensation, internal resistance enable, product calibration function, and measurement function. See the meaning of each parameter Table 50.CD-B provides calibration functions; users can calibrate by themselves or contact customer service for factory calibration.





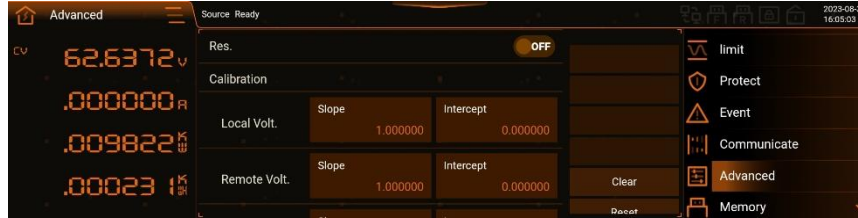

Figure 235 Advanced Settings Interface Figure

Table 50 Advanced Settings Parameters Table

Parameter Item	Unit	Explanation and Application	Model	Initial Value	Resolution	Setting Range
Trigger Input	/	Internal/external trigger can be selected.	ALL	Internal	/	/
Trigger Output	/	<p>After setting the trigger function in the Anyport digital output interface, the product will emit a pulse indication signal at the Anyport digital output port when outputting a programmed waveform. This operation requires enabling the trigger function in the Anyport digital output configuration interface, see section 7.3.1.2 for details. See the pulse trigger output waveform schematic in Figure 236.</p> <p>Single: Only when the programming starts executing, the output pulse indication signal is given.</p> <p>Single step: A pulse indication signal is issued during the execution of each sequence.</p> <p>Single cycle: A pulse indication signal is issued at the start of each cycle.</p>	ALL	Close	/	/

Parameter Item	Unit	Explanation and Application	Model	Initial Value	Resolution	Setting Range
Trigger delay	s	In programming mode, after pressing 'trigger', wait for the set trigger delay before starting to execute the program sequence.	ALL	ALL	/	0~999.999
Start mode	/	When automatic is selected, the product will automatically start up after being powered on.	ALL	Manual	/	/
Communication monitoring	s	After enabling, select any command or specific command. If no corresponding command is detected within a specific timeout period, the product will report a WDP fault, which can be restored to normal through a reset operation. See Section 5.3.3.	ALL	Off	/	/
Automatic operation	/	After enabling, the output will automatically turn on after the product is powered on.	ALL	Off	/	/
Voltage Zeroing	/	After enabling, when the output terminal is connected to a non-energy storage device, it can discharge quickly/slowly at a constant current after disconnecting the output terminal.	ALL	Slow	/	/
Energy Reset	/	After enabling, the battery capacity accumulates, and pressing the energy reset button will reset the capacity after disconnection.				
Remote Compensation	/	After enabling, it can compensate for the voltage drop in the line connecting the product to the user's equipment.	ALL	/	/	/
Internal Resistance Enable	/	After enabling, the internal resistance mode of this product is enabled, and an internal resistance setting column will appear in the output setting area.	ALL	/	/	/
Calibration	/	Includes six parameters: remote/near-end voltage slope, remote/near-end voltage intercept, current slope, and current intercept.	ALL	Slope: 1 Intercept: 0	0.00001	Slope: 0.8~1.2 Intercept: -20~20

Parameter Item	Unit	Explanation and Application	Model	Initial Value	Resolution	Setting Range
Reset Calibration	/	Reset the slope to 1 and the interception to 0.				
Measurement	/	The user can choose to display internal resistance/energy/capacity.	ALL	/	/	/

Note: Be cautious of danger and use it carefully after enabling automatic run.

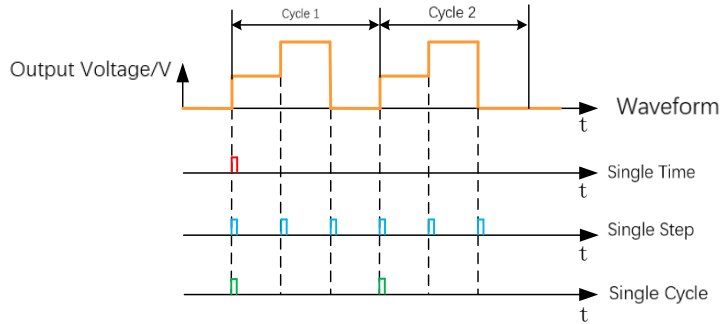

Figure 236 Trigger Output Schematic

7.13 Storage

Storage includes five parts: information, logs, parameters, waveforms, and files. For storage functions, see Figure 237.

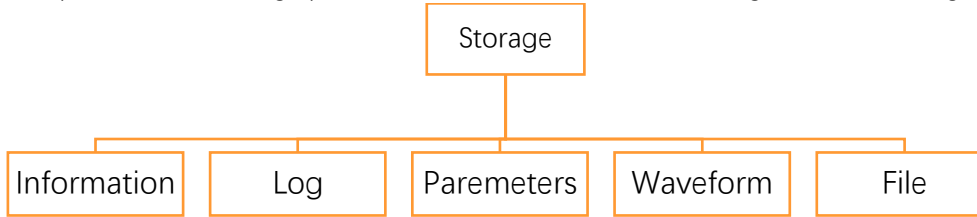

Figure 237 Storage Function Tree Diagram

7.13.1 Information

Click on Storage-Information in the menu bar to enter the information interface. The information interface records the operating status of CD-B, including operations, protections, alarms, and events, totaling 300 entries, see Figure 238.

The screenshot shows the 'Information' interface with a table of events. On the left, there are four digital readouts (DROs) for 'CV', 'R', 'K', and 'W' channels, each showing a value of 0.000000 except for 'W' which shows 0.000285. The table has columns for 'No.', 'Mode', 'Content', and 'Date'. A right-hand menu is visible with options like 'Communicate', 'Advanced', 'Memory', 'Information', 'Record', and 'Parameter'.

No.	Mode	Content	Date
1	Source Load	Handle: Off	2023-08-30 16:05:32
2	Source Load	Handle: On	2023-08-30 16:05:31
3	Source Load	Handle: Off	2023-08-30 16:04:22
4	Source Load	Handle: On	2023-08-30 16:03:52
5	Source Load	Protect: 0x1101	2023-08-30 12:22:57
6	Source Load	Protect: 0x1301	2023-07-18 18:26:26

Figure 238 Information Interface Diagram

7.13.2 Log

Click on Storage-Log in the menu bar to enter the log settings interface. The log settings interface is shown in Figure 239, where you can set the sampling rate, number of records, and recording method. The explanation of each parameter is shown in Table 51.



Figure 239 Log Settings Interface Diagram

Table 51 Log Settings Interface Parameters Explanation Table

Parameter Item	Unit	Explanation	Model	Resolution	Initial Value	Setting Range
Sampling Rate	sps	Sampling record rate, sps indicates the number of log entries recorded per second.	ALL	/	1	1,2,5,10
Number of Records	/	The number of log entries that can be recorded.	ALL	/	0	0~9999999
Recording Method	/	Log recording methods include Event Trigger and Immediate Trigger. Event Trigger: After pressing start, this product will trigger log recording when an event occurs. Event triggers need to set the action method in the event interface, as detailed in section 7.10.	ALL	/	Immediate Trigger	/

Parameter Item	Unit	Explanation	Model	Resolution	Initial Value	Setting Range
		Immediate Trigger: After pressing the start button, this product immediately triggers log recording.				
Start Button	/	After clicking the start button, the product will automatically record the event to an external USB storage device connected to the rear panel.	ALL	/	/	/

Note: 1. The external USB storage device on the rear panel supports FAT32 and exFAT formats.

2. Log files only support CSV format, with content separated by commas.
3. File naming rule: file name prefix + file number + group number, such as 'LOG' + '001' + '001'.
4. File splitting rule: The file will split the recorded log entries into segments of 5000 entries.
5. Log recording csv format diagram see Figure 240Log information parameter explanation sees Table 52.

	A	B	C	D	E	F	G	H	I	J	K	L	M	N	O	P	Q	R	S
1	FR2006	1020010003																	
2	Uset (V)	Iactual (A)	Isource (A)	Iload (A)	Iactual (A)	Psource (0W)	Fload (0W)	Factual (0W)	Factual (0Wh)	Qactual (Ah)	Rsource (ohm)	Rload (ohm)	Ractual (ohm)	Rmode	Output	Mode	Error	Event	Time
3	500	45.24097	30	30	1.51825	11.98229	11.98229	0.068687	0.032132	0.658251	N/A	N/A	N/A	OFF	OFF	CV	0x0000	0x0000	00:00:0
4	500	44.33328	30	30	1.502991	11.98229	11.98229	0.066632	0.032151	0.659693	N/A	N/A	N/A	OFF	OFF	CV	0x0000	0x0000	00:01:0
5	500	45.61362	30	30	1.507941	11.98229	11.98229	0.071629	0.032171	0.657115	N/A	N/A	N/A	OFF	OFF	CV	0x0000	0x0000	00:02:0
6	500	44.59043	30	30	1.522064	11.98229	11.98229	0.067854	0.03219	0.657547	N/A	N/A	N/A	OFF	OFF	CV	0x0000	0x0000	00:03:0
7	500	45.40236	30	30	1.51062	11.98229	11.98229	0.068585	0.03221	0.657979	N/A	N/A	N/A	OFF	OFF	CV	0x0000	0x0000	00:04:0
8																			

Figure 240 Log Record in CSV format figure

Table 52 Log Record information legend

Parameters	Explanation	Parameters	Explanation
CD30-2K0B	CD-B Model	Qactual(Ah)	Capacity display value
1020010003	Device serial number	Rsource(ohm)	Source internal resistance setting value
Uset(V)	Voltage setting value	Rload(ohm)	Load internal resistance setting value

Uactual(V)	Voltage display value	Ractual(ohm)	Internal resistance display value
Isource(A)	Source current setting value	Rmode	Internal resistance mode output status
Iload(A)	Load current setting value	Output	Output terminal output status
Iactual(A)	Current display value	Mode	Operating mode status
Psource(kW)	Source power setting value	Error	Protection Code
Pload(kW)	Load Power Set Value	Event	Event Number
Pactual(kW)	Power Display Value	Time	Record Time
Eactual(kWh)	Energy Display Value		

7.13.3 Parameters

Parameters include user and communication sections, see Figure 241 , all files can be imported/exported.

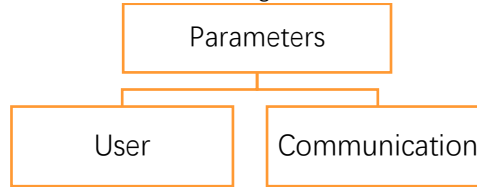

Figure 241 Parameter Function Tree Diagram

7.13.3.1 User

Click on Storage-Parameters-User in the menu bar to enter the user interface. The user interface is shown in Figure 242, including data from mode, parameters, limits, protection, events, advanced, Anyport, source load, and system, all saved as files.

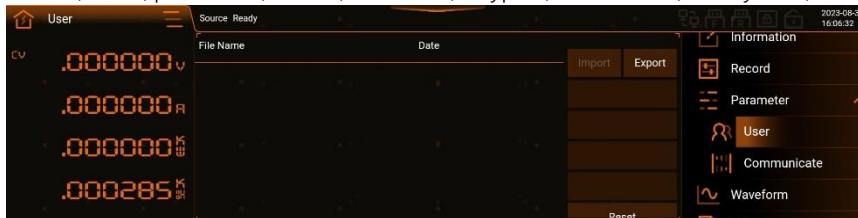

Figure 242 User Interface Diagram

7.13.3.2 Communication

Click on Storage-Parameters-Communication in the menu bar to enter the communication interface. The communication interface Figure 243, includes parameters from the communication settings interface in the menu bar, saved as files.

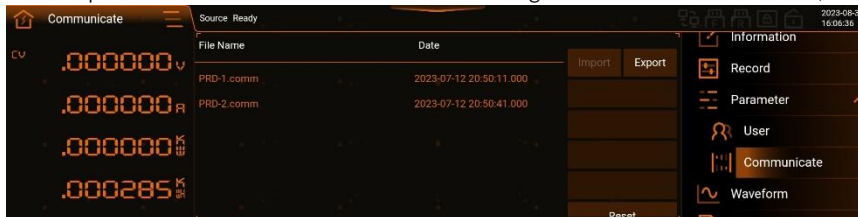

Figure 243 Communication Interface Diagram

7.13.4 Waveform

Click on Storage - Waveform in the menu bar to enter the waveform interface. The waveform interface is shown in Figure 244, where users can export/import waveforms using a USB storage device or a host computer on the front panel.

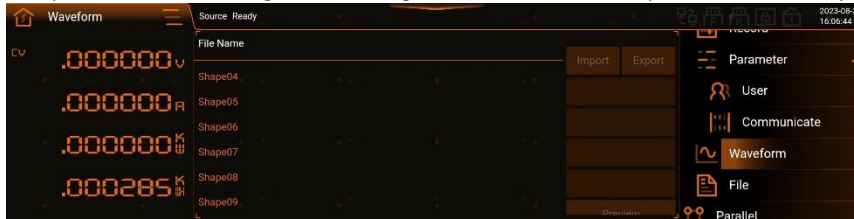

Figure 244 Waveform Interface Diagram

Select the waveform file and click 'Preview' in the bottom right corner to view the waveform of the current file.

7.13.5 File

Click on Storage - File in the menu bar to enter the file interface. The file interface contains all internal storage files and files from external USB storage devices.

The internal storage file interface of the product is shown in Figure 245.

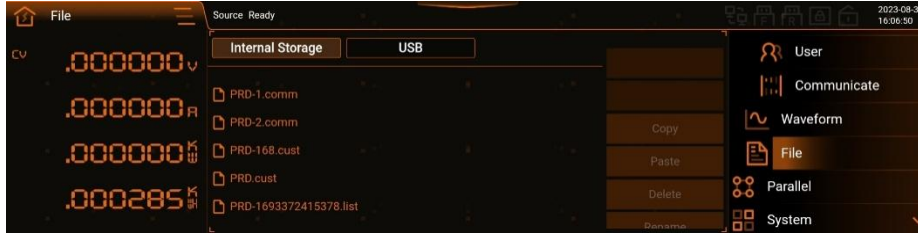

Figure 245 Internal Storage File Interface Diagram

The external USB storage file interface is shown in Figure 246.



Figure 246 External USB Storage File Interface Diagram

In the file interface, file interaction between internal storage and external USB storage devices can be achieved through copy/paste.

7.14 Parallel



When expanding the capacity of this product by connecting multiple units in parallel, please connect the positive and negative DC output busbars of the parallel products to each other. The wire diameter should be selected based on the maximum current, and the wires should be as short as possible.

This product supports multi-unit parallel expansion. Parallel configuration can be divided into columns and row directions. Column parallel configuration requires setting the column parallel as the host and the row parallel as a single unit in the host's parallel interface. The optical fiber connection method for column parallel can be referred to Figure 247 Column Parallel Optical Fiber Connection Diagram , and the parallel interface can be referred to Figure 248 Column Parallel Interface.

Column Parallel

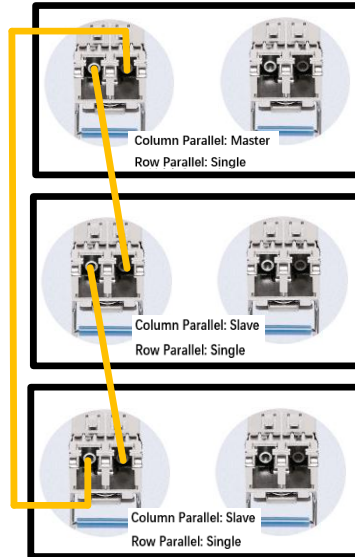

Figure 247 Column Parallel Optical Fiber Connection Diagram



Figure 248 Column Parallel Interface

Row parallel configuration requires setting the row parallel as the host and the column parallel as a single unit in the host's parallel interface. In the slave's parallel interface, set the row parallel as the slave and the column parallel as a single unit. The fiber optic connection method for row parallel can be referred to Figure 249 Row Parallel Fiber Optic Connection Diagram, the parallel interface for row parallel can be referred to Figure 250 Row Parallel Interface.

Row Parallel

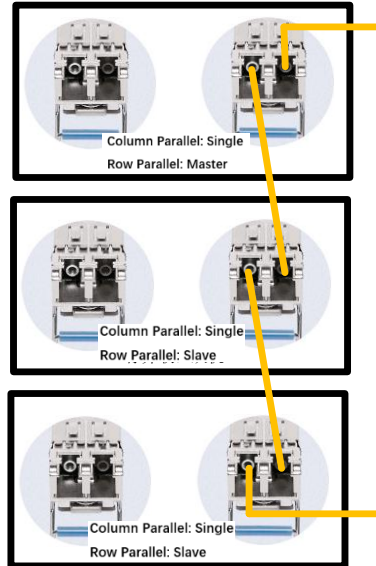

Figure 249 Row Parallel Fiber Optic Connection Diagram



Figure 250 Row Parallel Interface

Due to the limitation of communication speed in unidirectional parallel, in the parallel configuration, this product can be parallel separately in row and column directions to maximize capacity. Configuration - Parallel interface as shown in Figure 251 shown.



Figure 251 Parallel Interface Diagram

The parallel configuration method can be referred to as Figure 252 As shown perform fiber optic connection and interface settings, the arrow indicates the control direction, in the upper left corner the product uniformly controls other products.

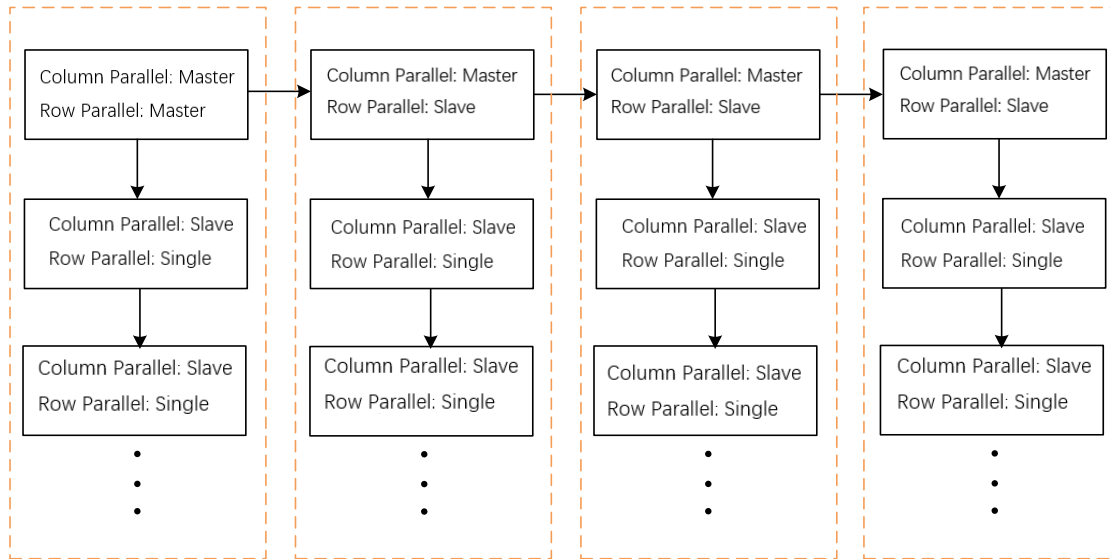

Figure 252 Parallel Configuration Diagram

Parallel Redundancy: During the operation of this product, if some slave units experience protection at the non-output end or AC end, if parallel redundancy is enabled, the remaining products can continue to operate and actively distribute current, if parallel redundancy is disabled, all other products will shut down the output end.

7.15 System

The system includes the screen and about two parts, as Figure 253 shown.

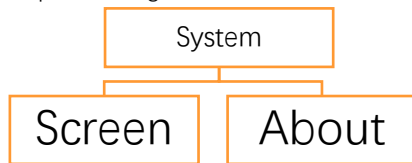

Figure 253 System Function Tree Diagram

7.15.1 Screen

Click System-Screen in the menu bar to enter the screen interface, as Figure 254. In the screen interface, you can set the language, alarm sound, date and time, and screen brightness.



Figure 254 Screen Interface Diagram

7.15.2 About

Click System-About in the menu bar to enter the about interface. In the about interface, you can see the device information and

software version of the CD-B, as Figure 255 shown. The device information includes the product model, hardware version number, local serial number, number of startups, and runtime (subject to actual conditions).

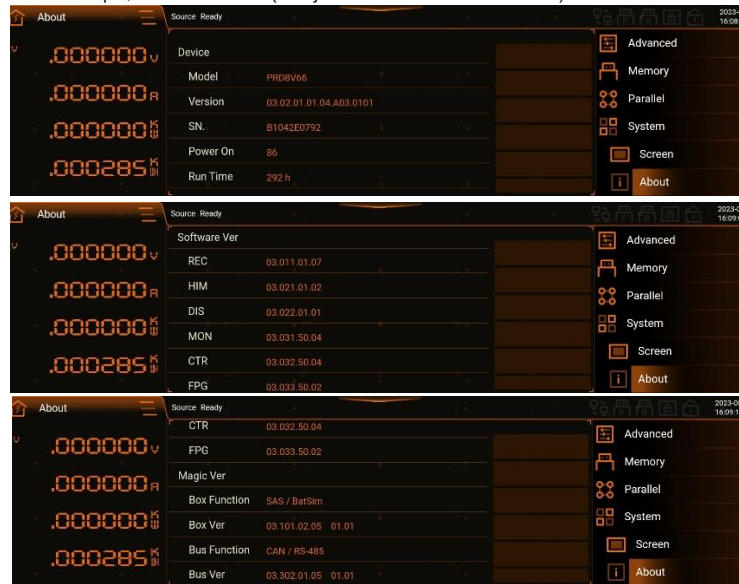

Figure 255 About Interface Diagram

Version Revision Record

Date	Version	Revision Content
July 2021	V1.0	Completion of this manual
August 2021	V1.1	Update <ul style="list-style-type: none">- Added 20kW specification and related parameter information to the entire document- Modified parallel wiring diagram in section 4.14- Modified SAS main interface diagram in section 6.2.3
December 2021	V1.2	Update <ul style="list-style-type: none">- Optimized the wording of some content- Modified Table 1 technical specifications in section 3.5, modified Power Curve Diagram<ul style="list-style-type: none">- Added parallel kit in Table 2 of section 3.6, which lists accessory names and quantities- Added power-temperature curve diagram and power-input voltage curve diagram in section 4.3.1- Modified Figure 24 remote compensation connection diagram in section 4.11- Modified Figure 25 parallel optical fiber connection diagram in section 4.14

-
- 5.3.1 Modify Table 3A nyport interface function table, add Anyport output interface external high-level schematic
 - 6.2.4 Add amplitude-frequency characteristic curve
 - 6.3.3 Modify the current upper limit and current lower limit in Table 14 limit function table
 - 6.4.2 Add detailed configuration instructions for column parallel and row parallel in parallel section
 - 6.4.5 Modify Table 17 Anyport input function table, Table 18 Anyport output function table, and part of the text description in Table 19 analog given range correspondence table

2022 Year 5 Month V1.3

Update

- Add watermark throughout the document
- Revise some formats and revise the table of contents

2022 Year 9 Month V 2.0

Update

- Added model specifications, modified and added some images
- Added Bat Sim battery simulation function
- Adjusted font size, updated the table of contents

2024 Year 9 Month V 2.1

Update

- Supplemented the meaning of safety markings in 2.3.1 Safety Precautions

- Added new sections on the validity of 2.1.3, standard configuration list in 3.6, etc., with specifications and parameters related to 38 E models, amplitude-frequency characteristics curves, and power curve diagrams

- 3.5 Section Technical Specifications Updated

- Replaced power voltage input curve in 4.3.1 Ventilation and Derating

- 6.3.3 Limit Value Added explanation of upper and lower limits of internal resistance

2024 Year 11 Month

V 3.0

Update

- The fifth section on the human-machine interface has been completely updated

- The seventh section on the human-machine interface has been completely updated